



USES AND
RACOMMENDS



www.tmracing.it

TM Racing SpA - Via Fano, 6
61122 Pesaro - ITALY
Phone: +39 0721 25113

2T112MXJ23-M

**MOTORE
ENGINE**

22/02/2023



INFORMAZIONI GENERALI

Il presente catalogo serve per richiedere con esattezza le parti di ricambio.

Nelle ordinazioni indicare:

1) Il numero di matricola del Telaio che è stampigliato sul lato destro del canotto di sterzo. Nei modelli EN, SMR, SMR il numero di matricola è riportato anche su una targhetta posta sul lato sinistro (Vedi foto).

2) il numero di serie del Motore. E' posto sulla sinistra del motore tra la leva cambio e i coperchio accensione (Vedi foto).

3) Il codice dei particolari seguito dalla descrizione.

4) Il colore per i pezzi verniciati o comunque colorati.

Le indicazioni destra e sinistra si riferiscono ai lati del veicolo rispetto al senso di marcia.

Foto e disegni sono solo a scopo informativo e potrebbero non corrispondere esattamente alle caratteristiche dei prodotti.

GENERAL INFORMATION

The present spare parts catalogue enables one to order exactly the right spare part.

When ordering specify:

1) The frame serial number. It is embossed on the right side of the steering metal tube. In the EN, SMR and SMR models, the serial number is also stated on a plate positioned on the left hand side (See photo).

2) The engine serial numer. It is located on the left side of the engine between the gear lever and the ignition cover (See photo).

3) The part's code number followed but its description.

4) Indicate colour for painted or colored parts.

References to right and left apply to the vehicle in terms of its direction of movement.

Photos and drawings are for informational purposes only and may not exactly match the characteristics of the products.

NOTE – LEGENDA

MY

NOVITA' INTRODOTTA DIFFERENTE O NON PRESENTE NEL MODELLO DELL'ANNO PRECEDENTE

PART DIFFERENT OR NOT PRESENT IN THE REVIOUS YEAR MODEL

5M

MOTORE CON CAMBIO A 5 MARCE
ENGINE WITH 5 GEARS SPEED

6M

MOTORE CON CAMBIO A 6 MARCE
ENGINE WITH 6 GEARS SPEED

KS

MOTORE CON SOLO KICK STARTER
ENGINE WITH KICK STARTER ONLY

ES

MOTORE CON AVVIAMENTO ELETTRICO
ENGINE WITH ELECTRIC STARTER

X

RICAMBIO NON DISPONIBILE ALLA VENDITA
PART CAN NOT BE SOLD SEPARATELY



Le illustrazioni riportate in questo manuale sono fornite solo come riferimento e possono variare dal prodotto effettivo,

Dati indicativi soggetti a modifiche senza impegno di preavviso.

The illustrations in this manual are for reference only and may vary from the actual product.

All data are subject to modification without prior notice.



2T112MXJ23-M
MOTORE - ENGINE

CILINDRO - CYLINDER.....	4
ALBERO MOTORE E PISTONE - CRANKSHAFT AND PISTON.....	6
ACCENSIONE - IGNITION.....	8
CENTRIFUGA E CARTER FRIZIONE - WATER PUMP - CLUTCH COVERS.....	10
FRIZIONE - CLUTCH.....	13
BASAMENTO E PACCO.....	16
MESSA IN MOTO - KICK STARTER.....	18
COMANDO CAMBIO - GEARSHIFT MECHANISM.....	20
CAMBIO - GEAR BOX.....	23
VITI COPERCHI.....	26
VITI BASAMENTO.....	28
-	30



2T112MXJ23-M
MOTORE - ENGINE

CILINDRO
CYLINDER

1

1	01139	1	CILINDRO 112 MY2021 CPL	
2	F21418	1	PIPETTA CANDELA NGK VD05FMH	CAP, NGK SPARK PLUG VD05FMH
3	F06105	1	CANDELA NGK CR9EIX CON/NIPPLO	SPARK PLUG NGK CR9EIX
4	49357	6	VITE TE F/R 6X25 Ch.8	BOLT 6X25 T.8
5	02031	1	TESTA 112 2T	
6	12003	1	O RING TESTA 125 90/06KVK8-910 NBR	O-RING, HEAD 125 90/06 KV8910
7	12021	1	O RING PREFORMATO CIL.125/12->	O-RING, HEAD 125EV M. 2012
8	49189	2	GRANO 4X10 PUNTA PIATTA	
9	05537.20	1	GUARN. B/CIL 112 M.2021 0,2	
9	05537.30	1	GUARN. B/CIL 112 M.2021 0,3	
9	05537.40	1	GUARN. B/CIL 112 M.2021 0,4	
9	05537.50	1	GUARN. B/CIL 112 M.2021 0,5	
10	26041	2	GRANO CENTRAGGIO D.7X8 F.5,2	DOWEL PIN 7 x 8 Hole 5,2
12	49401	1	VITE TSEI 5X16	BOLT TSEI 5x16
15	49402	2	VITE TSEI 5X20	BOLT TSEI 5X20
16	49630.3	2	DADO M 4 x 3	
17	22087	1	VALVOLA GHIGL. 112 MOD. 2020	
18	19079	1	RULLINO 4X30 V.SC.112	
19	19045	2	ASTUCCIO A RULLI HK 0810	NEEDLE BUSH HK 0810
20	28026	1	ALBERINO COM VAL. 125/250 99/11	SHAFT P.VALVE 125/250 M. 99/05
21	28039	1	PIASTRINO SUP.V 80/125 99/06 250 97/05	UP PLATE, VALVE 80/125 99/06
22	49701	1	DADO M 5 FLANGIATO VALV.	NUT 5mm, FLANGED VALV.
23	04006	1	PARAOLIO VALV.SCARIC.G.8x12x3	OIL SEAL 8 x 12 x 3
24	16057	1	MOLLA ALBERINO VALV.85 M13 1.5	SPRING EXH.VALVE SHAFT 85cc1,5
27	49355	2	VITE TE F/R 6X16 Ch.8	BOLT 6X16 T.8
28	13089	1	COLLETTORE SCARICO 112	
31	01126	1	CILINDRO 112 M2020 NUDO	



2T112MXJ23-M
MOTORE - ENGINE

ALBERO MOTORE E PISTONE
CRANKSHAFT AND PISTON

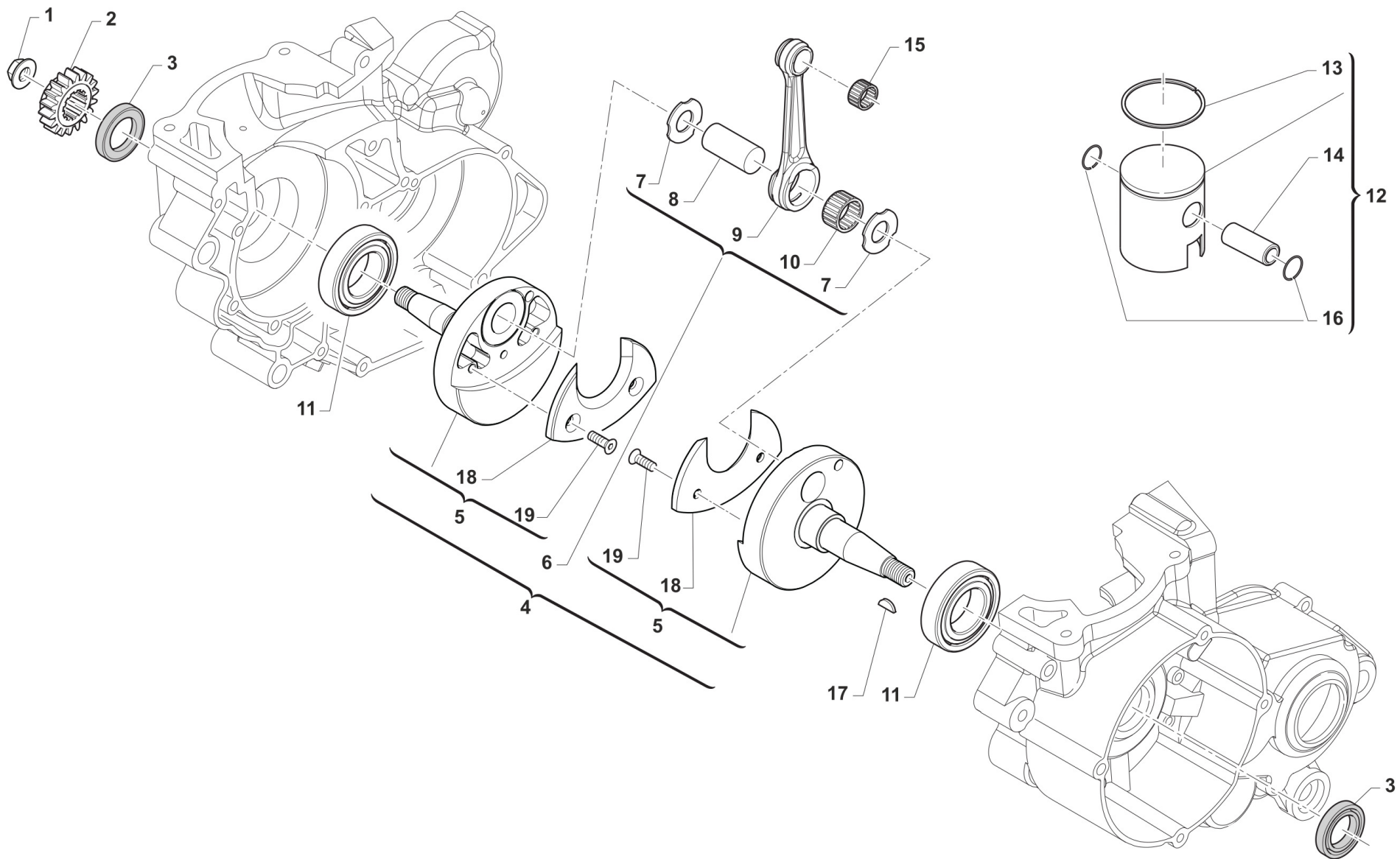

TM0173



2T112MXJ23-M
MOTORE - ENGINE

ALBERO MOTORE E PISTONE
CRANKSHAFT AND PISTON

2

1	49056	1	DADO ACCENS 100/TAG/KZ 125MX/E	NUT, IGNITION 100cc
2	40055	1	PIGNONE COPPIA PRIM.Z15 80 M06	PRIMARY DRIVE GEAR 15T 80 M.06
3	04035	2	PARAOLIO 20x30x7 PTFE	OIL SEAL 20 x 30 x 7 PTFE
4	18288	1	ALBERO MOTORE 112 CC CPL	
5	18272	1	COPPIA SEMIALBERI MOTORE 112 CC	
6	18147	1	BIELLA 112cc MY2021 CPL	
7	18061	2	RONDELLA ARGENTATA D.20X34X1	WASHER, SILVER ID.20
8	18271	1	ASSE ACCOP. 20 X 48 FORO 5	CON-ROD PIN 20 X 48 H. 5mm
9	18146	1	BIELLA 112cc ASSE D.20mm L.104 NUDA	
10	17020	1	GABBIA ARGENTATA D. 20 IKO	SILVER CAGE D.20
11	03020	2	CUSCINETTO RULLI NJ205ET2XC3 (BANCO 85/100 M.18)	BUSH CRANKSHAFT 85/100->18 NJ205ET2XC3
12	10027.95	1	PISTONE D.51,95 112cc COMPLETO	
12	10027.96	1	PISTONE D.51,96 112cc COMPLETO	
12	10027.97	1	PISTONE D.51,97 112cc COMPLETO	
13	11060	1	SEGMENTO 100 cc CR.52 X 2 (112)	PISTON RING 100cc CR.52X2
14	09021	1	SPINOTTO PISTONE 112 39 x 14 F.9	
15	19035	1	GABBIA SPINOTTO 100 CC KART e 112 cc MX	TOP END B. KART 100cc
16	09020	2	ANELLINO PISTONE 112cc D.14x1 TYPE C	
17	49010	1	CHIAVETTA VOLANO 13x5x3	WOODRUFF KEY
18	18141	2	GUANCETTA AL SEMIALBERO 112	
19	49403U	4	VITE TSEI 6x12 UNBRAK UNI 5933	BOLT TSEI 6X12 UMB.



2T112MXJ23-M
MOTORE - ENGINE

ACCENSIONE
IGNITION

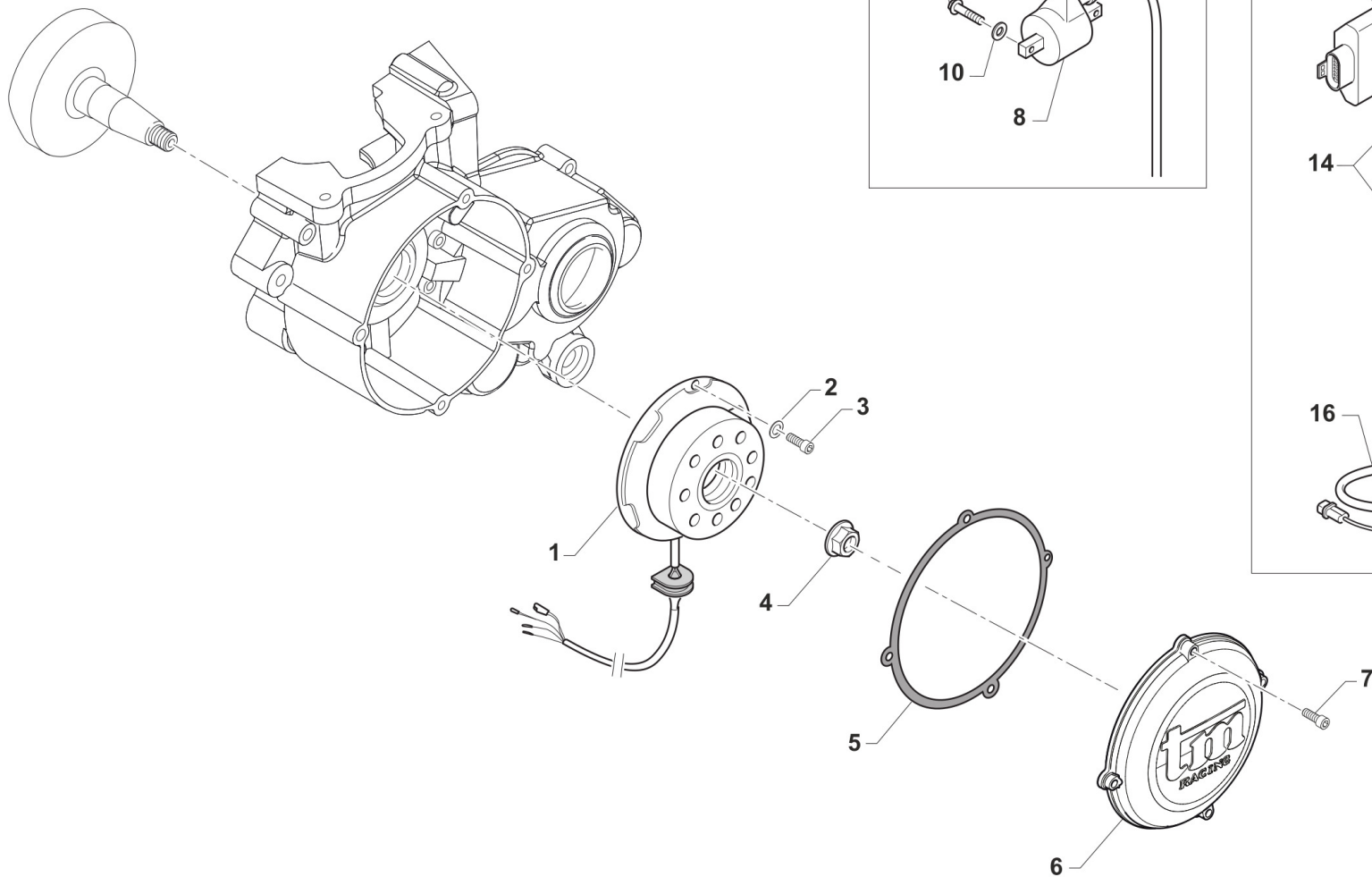

0178.01



2T112MXJ23-M
MOTORE - ENGINE

ACCENSIONE
IGNITION

3

1	15230	1	GENERATORE KOK END 11 MX/E 12	GENERATOR KOK END 11 MX/E 12->
2	49902	2	RONDELLA 6,5X13X3	
3	49484	2	VITE TCEI 6X20	BOLT TCEI 6X20
4	49056	1	DADO ACCENS 100/TAG/KZ 125MX/E	NUT, IGNITION 100cc
5	05516	1	GUARN. COP.ACC. 80/125 KOKUSAN	GASKET, KOK.IGNIT.COV. 80/125
6	30211	1	COP. ACC. MX 125/144 06/11 E11	COVER, IGNITION MX 80/125 2006 KOK.
7	49477	4	VITE TCEI 5X25 UNI 5931-912 Brun	BOLT TCEI 5X25
8	15206	1	BOBINA KOKUSAN PIC. 2T IG7112	COIL, KOKUSAN 2 STROKE IG7112
9	49357	2	VITE TE F/R 6X25 Ch.8	BOLT 6X25 T.8
10	49603	2	RONDELLA M 6,4 X 12 X 1,6	WASHER 6x12
11	15209.112001	1	CENTRALINA TM IG_MX 112_01	
12	F15562	1	SUPPORTO CENTRALINA KOKUSAN	HOLDER ECU KOKUSAN
13	F26537	1	PIASTR.FISS.SUP.ECU KOK.F15562	PLATE HOLDER UCU KOKUS. F15562
14	49633	2	DADO M 5 BASSO AUTOBLOCCANTE	NUT 5mm, LOW SELF-LOCKING
15	49317	2	VITE TB LARGA 5X10 LAT.SERB.94	BOLT TB LARGE 5X10
16	68120	1	CABLAGGIO CDI KOK 2T 08/10	WIRE ECU KOKUSAN 2S 08/10

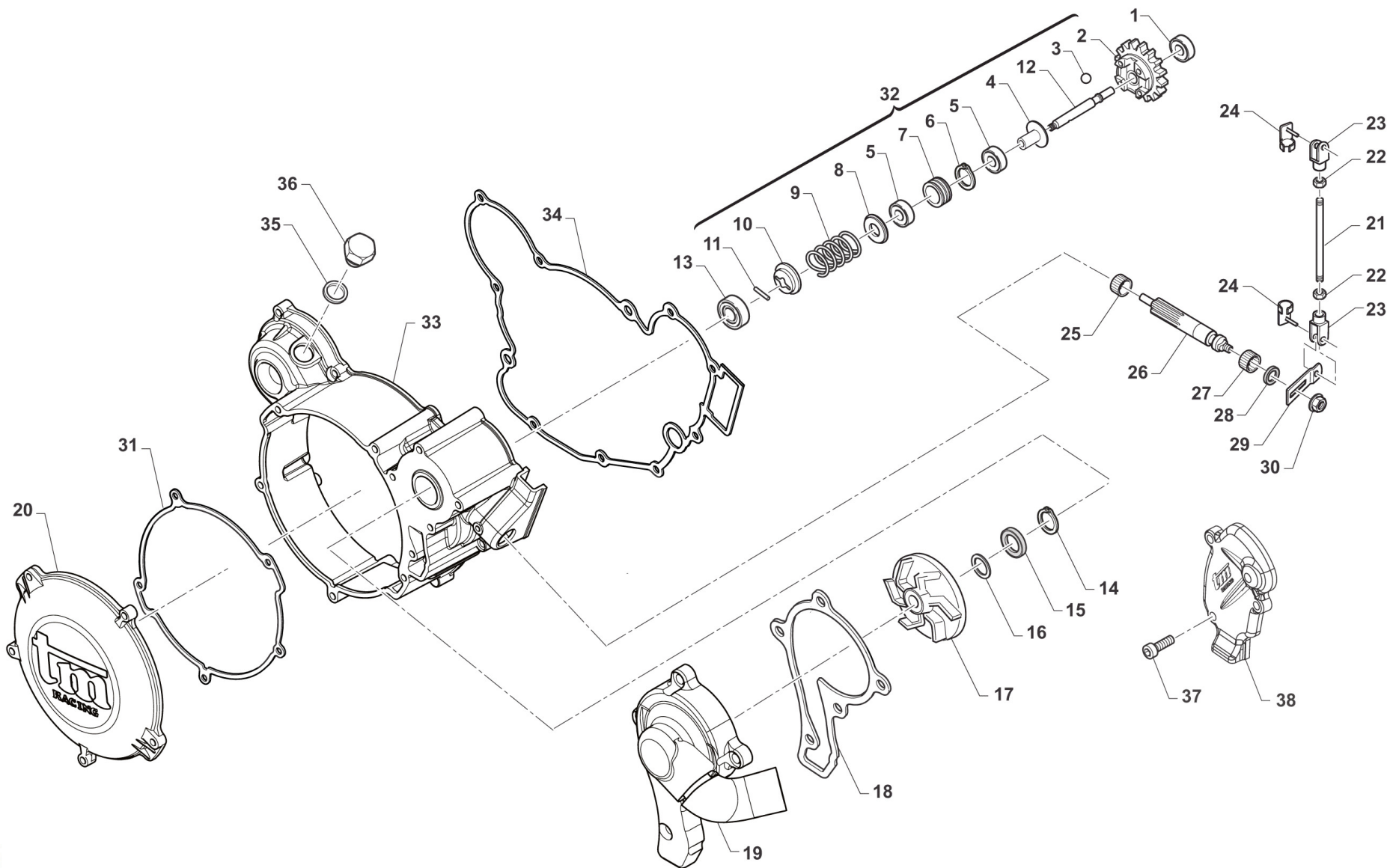

0175.01



2T112MXJ23-M
MOTORE - ENGINE

CENTRIFUGA E CARTER FRIZIONE
WATER PUMP - CLUTCH COVERS

4

1	03025	1	CUSCINETTO 626 C3 POMPA H2O 06	BUSH, WATER PUMP 626 C3
2	40056	1	INGR. VALVOLA CENTRIF. 85 2006	EXHAUST VALVE GEAR 80cc M.06
3	19054	4	SFERA D.12	BALL DIAM. 12 mm
4	40065	1	BUSSOLA PER CENTRIFUGA 10/11	SPIN BUSH 10/11
5	03028	2	CUSCINETTO 61901 MODIFIC 10/11	BUSH, 61901
6	49263	1	SEEGER I 24	SEEGER I 24
7	40059	1	RUOTA DENTATA CENTRIFUGA 10/11	GEAR SPIN WHEEL 10/11
8	48031	1	RONDELLA GUIDA MOLLA ANT.2010	WASHER, SPRING, FRONT
9	16056	1	MOLLA CENTRIFUGA JUNIOR 2013	SPRING, SPIN EXHAUST VALVE J13
10	48024	1	RONDELLA GUIDA MOLLA PST.06(2)	WASHER, SPRING, REAR
11	F19503	1	RULLINO D.3 X 13.8	PIN D.3 X 13,8 F.S.
12	28004	1	ALBERINO POMPA E CENTR.2006	SHAFT, WATERPUMP 2006
13	03014	1	CUSCINETTO 608 ZC3 POMPA SCHER	BUSH, WATER PUMP 608 Z C3
14	49215	1	SEEGER I22 POMPA ACQUA	CIRCLIP D.22 WATER PUMP
15	04017	1	PARAOLIO CENTRIFUGA 06 +MF1TAG	OIL SEAL 8 X 22 X 7 TC
16	49689	1	RONDELLA 6 X 12 SP. 1.2	WASHER 6x12 sp. 1,2
17	28009	1	GIRANTE POMPA ACQUA 2006/08	IMPELLER, WATER PUMP M.06/->
18	05528	1	GUARN. POMPA ACQUA 125 2006	GASKET WATER PUMP 125cc 2006
19	30194.112	1	COPERCHIO POMPA H2O 112 CC	
20	30187	1	COPERCHIETTO FRIZ. 125 M.2006	COVER, CLUTCH, EXT. 125 06/->
21	28044	1	ASTINA VALVOLA 93,5 mm 125/112 CR/E 2006	ROD, POWER VALVE 125 MX/E 2006
22	49630	2	DADO M 4 (BASSO)	NUT 4mm, LOW
23	49041	2	FORCHETTINA M4 X VALVOLA SC.	FORK, POWER VALVE ROD
24	49042	2	MOLLA BLOCCA FORCHETTINA M4	SPRING, POWER VALVE FORK M4
25	19048	1	ASTUCCIO A RULLI HK 0608	NEEDLE CAGE HK 0608
26	28005	1	ALBERINO COM. VALVOLA SC.06/10	SHAFT, INLET VALVE 2006
27	19044	1	GABBIA A RULLI FRENO POST.	NEEDLE BUSH REAR BRAKE PEDAL
28	F04354	1	PARAOLIO G 12X16X3 POMPA OLIO	OIL SEAL G 12/13/3 OIL PUMP



2T112MXJ23-M
MOTORE - ENGINE

CENTRIFUGA E CARTER FRIZIONE
WATER PUMP - CLUTCH COVERS

4

29	28043	1	PIASTRINO INF. VALV. 125/2006	VALVE LOW PLATE 125/2006
30	49701	1	DADO M 5 FLANGIATO VALV.	NUT 5mm, FLANGED VALV.
31	05526	1	GUARN. COP.FRIZ. EST.125 06/->	GASKET, EXT.CLUTCH COVER 125/6
32	28004.85	1	ALBERINO POMP.CENTR 85 CPL 13>	SHAFT, WATERPUMP 85 ASSY 13->
33	30186	1	CARTER FRIZIONE 125 M.06/11	COVER, INT CLUTCH 125 M.06/11
34	05527	1	GUARN. COP.FRIZ. INT.125 06/->	GASKET, CLUTCH CASE 125 06/->
35	49103	1	RONDELLA 14X20X1,5 ALLUMINIO	WASHER, 14 X 20 X 1.5 ALUMINUM
36	49300	1	TAPPO CARICO OLIO	OIL PLUG, FILL
37	49472	3	VITE TCEI 5X12 UNI 5931-912 Brun	BOLT TCEI 5X12
38	30296	1	COPERCHIO LEVERAGGI 112 2T	

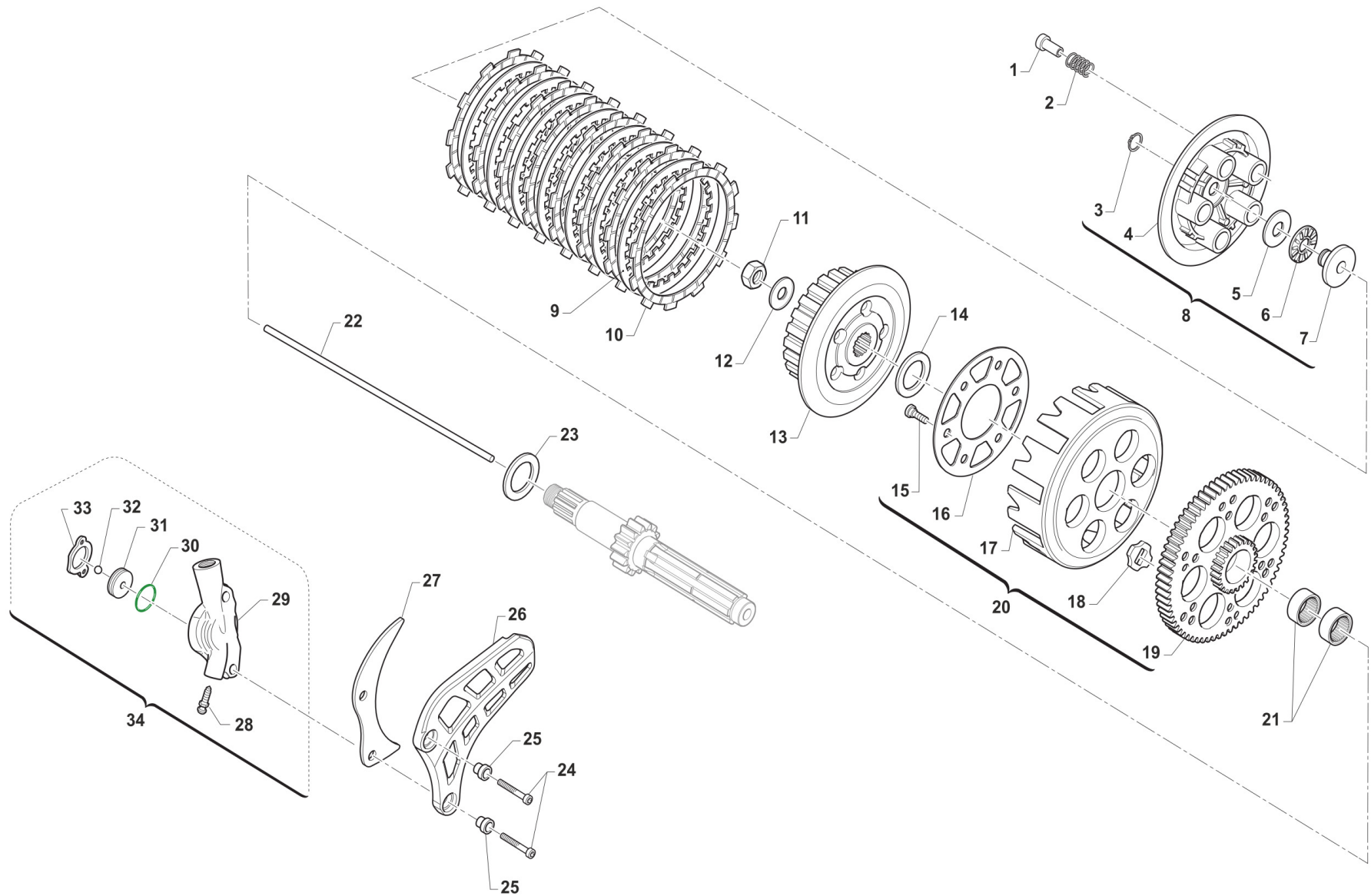

TM0174



2T112MXJ23-M
MOTORE - ENGINE

FRIZIONE
CLUTCH

1	49058	5	DADO FRIZIONE ERGAL 85CC 2014	NUT, CLUTCH 85cc ERGAL 14->
2	16020	5	MOLLA FRIZIONE 125 C/E 03/08BA	SPRING, CLUTCH 125 MX/E 03/->
3	49211	1	SEEGER E10x1 ANELLO PIATT.REG.	CIRCLIP D.8,4 - EXTERNAL
4	35015	1	PIATTO SPINGIDISCO FRIZIONE 125 97->	PLATE, CLUTCH PRESS.125 97/02
5	19021	1	RONDELLA X GABBIA RULLI AS1024	WASHER, NEEDLE CAGE AS 1024
6	19020	1	GABBIA A RULLI RAD. AXK 1024	NEEDLE CAGE AXK 1024, RADIAL
7	26001	1	REGGISPINTA FRIZIONE	CLUTCH THRUST
8	35025	1	PIATTO SPING.FRIZ 125/KART CPL	PLATE, CLUTCH PRESSURE ASSY
9	35019	7	DISCO FRIZ. ACC. 1mm 99/05	CLUTCH PLATE, STEEL 1mm 99/05
10	35012	8	DISCO FRIZ. GUARN.CR/E M.93->	CLUTCH PLATE, FIBER 85/125 MX/E 93/->
11	49052	1	DADO TAMBURELLO FRIZIONE	NUT, CLUTCH CENTER
12	49127	1	MOLLA A TAZZA DIN 2093 28X14,2X1,25	DISC SPRING DIN 2093 28x14,2x1,25
13	25099.14	1	TAMBURELLO FRIZIONE 125 2014	CLUTCH CENTRE 125cc M.14->
13	50124	1	CHIAVE FRIZ. 85/125 + KART CPL	CLUTCH TOOL 85/125cc + KART
14	48002	1	SPESSORE COP.PRIM.30X18X3	SPACER 30x18x3
15	49727	6	VITE PARASTRAPPI K9 M7X1X12.5	SCREW, M7X1X12,5 K9 ENGINE
16	35026	1	DISCO BATTUTA GOMM. FRIZ.KZ10B 85/125	DISC STOP RUBBERS CLUTCH KZ10B
17	25000	1	CAMPANA FRIZ.125 M.91/96 99/13	CLUTCH BASKET 125 91/96 99/05
18	21005	6	GOMMINO PARASTRAPPI FRIZIONE	RUBBER, CLUTCH BASKET
19	40400	1	COPPIA PRIM. 80/85 Z66	PRIMARY GEAR 66T, 80/85
20	40404	1	COPPIA PRIM. 80/85 Z66 CPL/CAM	PRIMARY GEAR 66T, 80/85 Comp.
21	19013	2	GABBIA A RULLI K 20X24X12	NEEDLE CAGE 20 X 24 X 12
22	35043	1	ASTINA FRIZ. IDR. 125 M.99/10	ROD, HYDR.CLUTCH 125 M. 99/04
23	48003	1	SPESSORE COP.PRIM.30X20X2	SPACER 30X20X2 PRIMARY GEAR
24	49486	2	VITE TCEI 6X30 UNI 5931	BOLT TCEI 6X30
25	26212	2	BOCCOLA PROT. PIGNONE 125 F.6	COLLAR, SPROCKET 125cc H.6
26	40029	1	PROTEZIONE PIGNONE 09/-> PLAST	PROTECTION FRONT SPROCKET09/13
27	40022	1	PROTEZIONE ERGAL PIGNONE CAT.	PROTECTION, GEAR CHAIN ERGAL



2T112MXJ23-M
MOTORE - ENGINE

FRIZIONE
CLUTCH

5

28	35264	1	VITE SPURGO OLIO FRIZ.IDR.6X1	SCREW AIR BLED HYDRAUL.CLUTCH
29	30205	1	COP. FRIZ/IDR 80/125 95/11 NUD	OUTPUT H.CLUTCH CYLINDER
30	12259	1	O RING PISTONE FR.125/250VERDE	O-RING, CLUTCH PISTON 125/250
31	35125	1	PISTONE POMPA FRIZ. 125 95/->	PISTON, CLUTCH PUMP 125 95/04
32	19052	1	SFERA 8 X FRIZIONE 250 5/16"	BALL, IDR. CLUTCH PUMP
33	05509	1	GUARN. POMPA FRIZ.IDR. 80/125	GASKET, HYDRAULIC CLUTCH80/125
34	30206	1	COP. FRIZ/IDR 85/125 95/-> CPL	OUTPUT H.CLUTCH CYLINDER CPL.

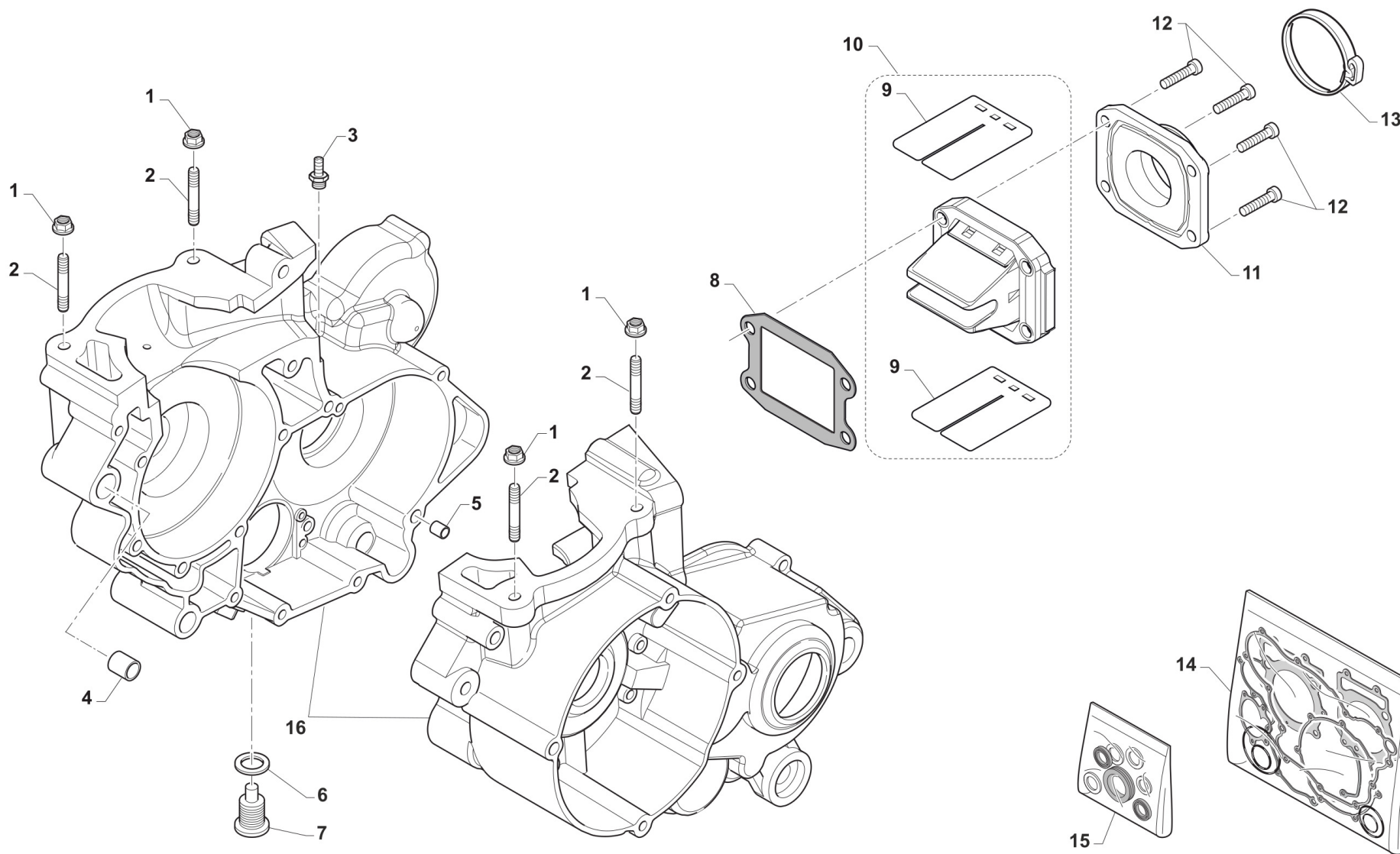

TM0176



2T112MXJ23-M
MOTORE - ENGINE

BASAMENTO E PACCO

6

1	49640	4	DADO M 8 FLANGIATO CHIAVE 12	NUT 8mm, FLANGE
2	49043	4	PRIGIONIERO CIL.M8X48,5 85/100	
3	49002	1	RACCORDO SFIATO VALV.MOT.F.D.3	FITTING VENT VALVE
4	26043	1	GRANO CARTER ANT. 14 X 14	GRUB SCREW 14X14
5	26044	1	GRANO CENTRAGGIO MOTOR.10X13,6	GRUB SCREW 10X13,6
6	49103	1	RONDELLA 14X20X1,5 ALLUMINIO	WASHER, 14 X 20 X 1.5 ALUMINUM
7	49301	1	TAPPO OLIO C/CALAM. 2T	OIL PLUG WITH MAGNET
8	05262	1	GUARN. PACCO LAMELLE 80/85	GASKET, REEDS VALVE 80/85cc
9	20092	1	LAMELLE V-FORCE 4R 85/100	
10	20090	1	PACCO LAMELLARE 112 VF4	
11	13095	1	COLLETTORE ASP.80/85'13 KEI.28	INLET MANIFOLD 85 13-> KEIH.28
12	49484	4	VITE TCEI 6X20	BOLT TCEI 6X20
13	51063	1	FASCETTA SM9 D.40	CLAMP SM9 D.40mm
14	05627	1	KIT GUARN. + OR 112 CC	
15	04037	1	KIT PARAOLI 85/100 MOD. 2016/2022	OIL SEAL 85 / 100 MY 18->
16	30297	1	BASAMENTO MOTORE 112 2021	



2T112MXJ23-M
MOTORE - ENGINE

MESSA IN MOTO
KICK STARTER

1	43038	1	LEVA M/M 80/125 M. 99/->	LEVER, KICK STARTER 125 99/->
2	49368	1	VITE TE F/R 6X10 LEVA M/M	BOLT 6X10 (Kich Starter)
3	04005	1	PARAOLIO ALBERINO M/M 15x24x7	OIL SEAL 15 x 24 x 7
4	26005	1	DISTANZIALE MOLLA M/M	SPACER, KICK STARTER SPRING
5	16008	1	MOLLA M/M 80 / 125 / 144 cc	SPRING, KICK STARTER
6	49406	1	VITE TSEI 6X20	BOLT TSEI 6x20
7	12260	1	O RING INTERNO LEVA M/M 250	O-RING INT.LEVER KICK START250
8	43039.01	1	MOZZETTO KICK START 125 M. 96 ->	
9	16039	1	MOLLA X SFERA LEVA M/M 250 CC	SPRING, BALL KICK-START. 250cc
10	43250.03	1	SFERA 1/4C X LEVA M/M 250 CC	BALL, KICK STARTER LEVER 250cc
12	48008	1	RONDELLA ALBERO MESSA IN MOTO	WASHER, KICK STARTER SHAFT
13	19010	1	GABBIA A RULLI K 15X19X10	BUSH NEEDLE CAGE 15 X 19 X 10
14	28051	1	ALBERO MESSA IN MOTO 125/144 96/18	SHAFT, KICK STARTER 125 96/05
15	40350	1	INGRANAGGIO SCORREVOLE M/M 125 / 144	SLIDING GEAR, KICK STARTER 125
16	16006	1	MOLLA X INGRANAGGIO M/M	SPRING, KICKSTART SLIDING GEAR
17	26254	1	LEVA BATTUTA M/M 125/250 96/->	STOPPER, KICK STARTER
18	49214	1	SEEGER E15 INGRANAGGIO M/M	CIRCLIP GEAR K.S. 15mm
19	48004	2	SPESSORE INGRANAGGIO M/M	SPACER, K.STARTER GEAR
20	40351	1	INGRANAGGIO LIBERO M/M 125 / 144	GEAR, KICK STARTER 125

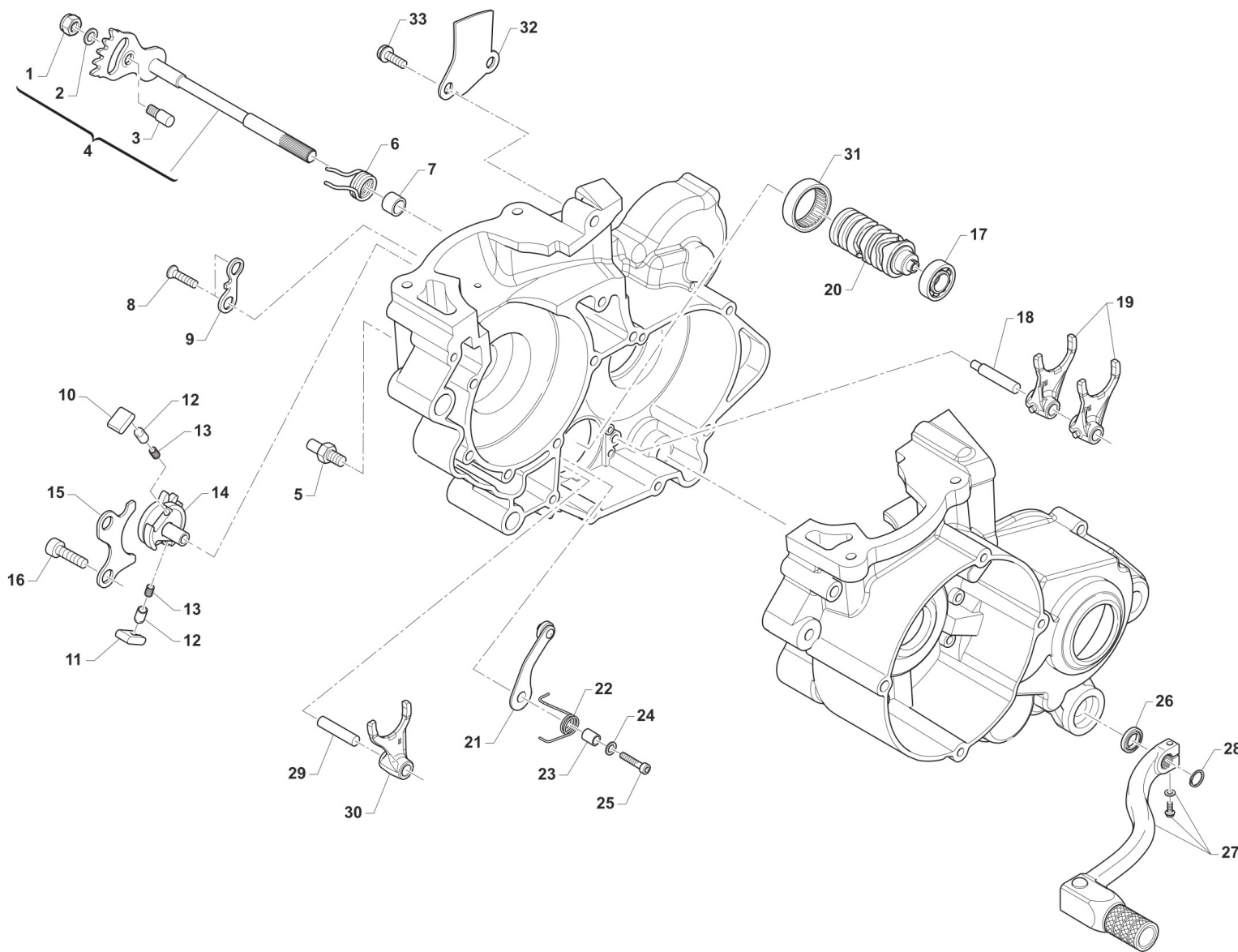

0702



2T112MXJ23-M
MOTORE - ENGINE

COMANDO CAMBIO
GEARSHIFT MECHANISM

1	49638	1	DADO M 6 ALTO AUTOBLOCCANTE	NUT 6mm, HIGHT SELF-LOCKING
2	49603	1	RONDELLA M 6,4 X 12 X 1,6	WASHER 6x12
3	26050	1	BATTUTA ECCENTRICA	ADJUSTER SELECTOR SHAFT
4	28100	1	ALBERO COMANDO ING. P.TACRIC.	SHAFT, GEARSHIFT
5	26051	1	BATTUTA FISSA LEVA CAMBIO INT.	PLATE INT. END STROKE GEAR LEVER
6	16009	1	MOLLA RITORNO LEVA CAMBIO 32CR	SPRING, RETURN GEAR LEVER 3,2
7	26006	1	DISTANZIALE MOLLA LEVA CAMBIO	SPACER, GEAR LEVER SPRING
8	49405	2	VITE TSEI 6X20 UMB.5933 10.9	BOLT TSEI 6x20 U.5933 10.9
9	26022	1	PIASTRINO FINE CORSA	PLATE END STROKE GEAR LEVER
10	26060	1	CRICCHETTO CAMBIO SUPERIORE	RATCHET UP, GEAR
11	26061	1	CRICCHETTO CAMBIO INFERIORE	RATCHET DOWN, GEAR
12	26062	2	PUNTALE PER CRICCHETTO CAMBIO	PIN, RATCHET GEAR
13	16012	2	MOLLA PER PUNTALE	SPRING, GEARBOX PIN
14	40310	1	INGRANAGGIO PORTACRICCHETTI	DRUM SHIFTER GEAR
15	26021	1	PIASTRINO RIENTRO CRICCHETTI	PLATE, RATCHET
16	49483	2	VITE TCEI 6X16 UNI 5931	BOLT TCEI 6X16
17	03012	1	CUSCINETTO DESMODROMICO 6001 2RS	BUSH, 6001 2RS GEAR DRUM
18	33256	1	PERNO FORCH.ALB.SEC. 250 / 125.99	AXEL, COUNTERSHAFT FORK 250cc
19	F33314	2	FORCHETTA A/S 125/250/300 CROM	SHIFT FORK SECONDARY 125/250CR
20	33004	1	ALBERO DESM.125 INTEGR. 6M CPL 125/144 6 M. CPL DI F26476	GEAR DRUM 125 6SP. 125/144 ASSY F26476
21	26063.12	1	PIASTRINO BLOCCAMARCE 2012 CPL	PLATE STOP GEAR ASSY M.12->
22	16252	1	MOLLA BLOCCAMARCE 125 / 250 2T	
23	26007	1	DISTANZIALE MOLLA BLOCCAMARCE	SPACER, STOP GEAR SPRING
25	49485	1	VITE TCEI 6X25 UNI 5931	BOLT TCEI 6x25
26	04004	1	PARAOLIO POMPA H2O-LEVA CAMBIO	OIL SEAL 12 x 22 x 5
27	43048	1	LEVA CAMBIO 2014 + 12MM (253) 85/125/144 2T 250Fi	GEAR LEVER 2014 +12mm
28	49212	1	SEEGER E12 LEVA CAMBIO	CIRCLIP D.12 - EXTERNAL
29	33255	1	PERNO FORCH.ALB. PRIM.250 / 125.99	AXEL, MAINSHAFT FORK 250cc



2T112MXJ23-M
MOTORE - ENGINE

COMANDO CAMBIO
GEARSHIFT MECHANISM

30	33016	1	FORCHETTA ALB.PRIM.125 PRT.CRM	SHIFT FORK MAINSHAFT 125 CROM.
31	19041	1	ASTUCCIO A RULLI DHK 35/12	BUSH NEEDLE CAGE DHK 35/12
32	26023	1	PIASTRINO CONVOGLIATORE OLIO	PLATE, OIL
33	49440	2	VITE TE 6X14	BOLT TE 6X14

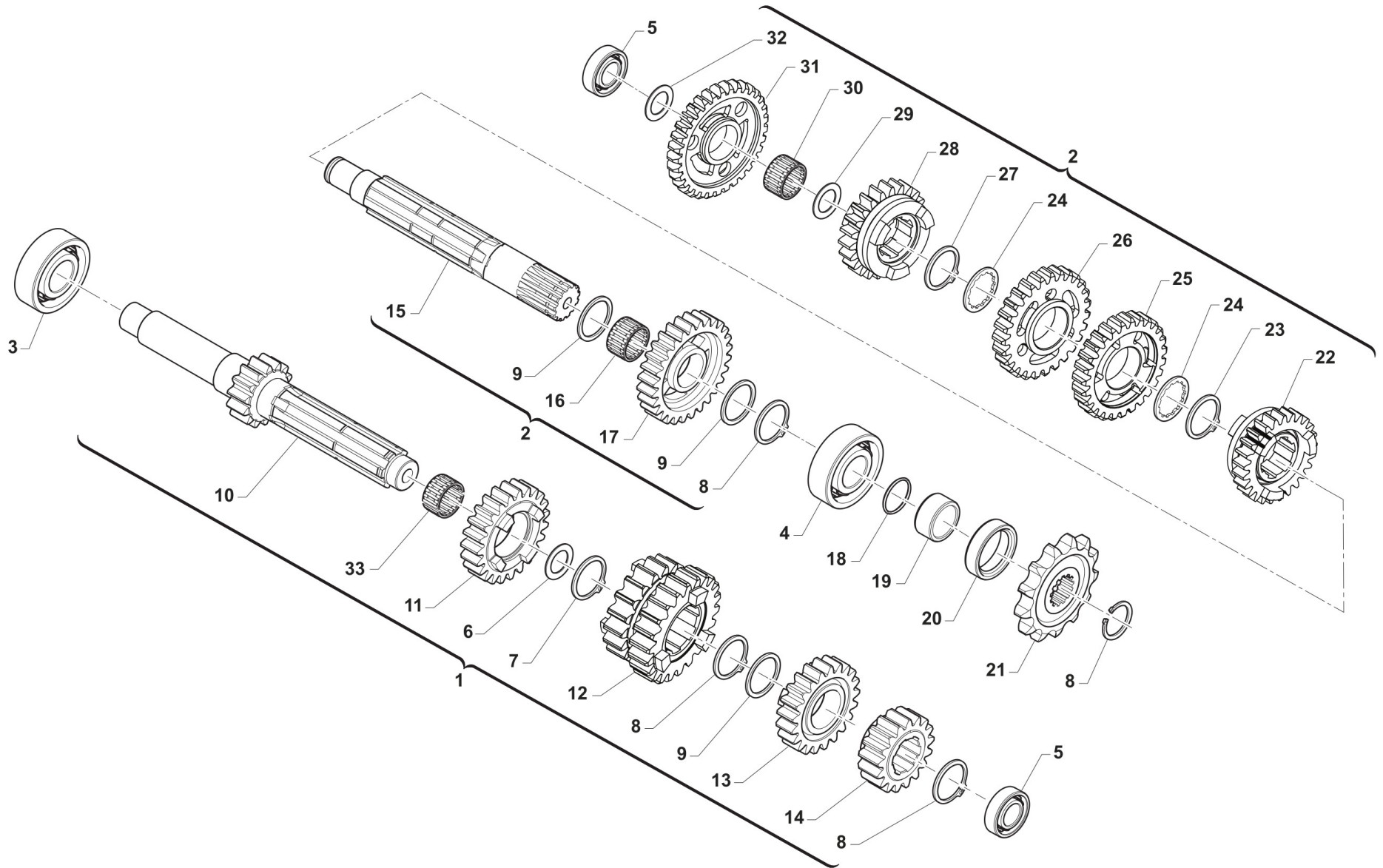



2T112MXJ23-M
MOTORE - ENGINE

CAMBIO
GEAR BOX

1	40003	1	ALBERO PRIMARIO CPL 85/100 CC J/MX	PRIMARY ASHFT ASSY 85/100
2	40004	1	ALBERO SECONDARIO CPL 85/100 CC J/MX	SECONDARY SHAFT ASSY 85/100
3	03011	1	CUSCINETTO ALBERO PRIM. 6204 Z C3	BUSH, GEAR MAINSHAFT
4	03010	1	CUSCINETTO 6204 C3 PIG.CATENA	BUSH, COUNTERSHAFT / SPROCKET
5	03080	2	CUSCINETTO 6202 Z C3 (CON RIVETTI) CAMBIO	BUSH, CRAKSHAFT CLUTCH SIDE
6	48041	1	RASAMENTO A/P 27.5X21X1 KZ10B	SPACER, MAINSHAFT 27,5X21X1 KZ
7	49222	1	SEEGER E 21 mm	CIRCLIP D.21 - EXTERNAL
8	49216	4	SEEGER E20 PIGN.-CAMBIO-COPPIA	CIRCLIP D.20 - EXTERNAL
9	48013	3	RASAMENTO A/S 27X20X0,7	SPACER, 27x20x0,7
10	40713.85	1	ALBERO PRIMARIO Z 14 85CC RINF.CON SEDE SEEGER	PRIMA SHAFT 14T 85/100
11	40440	1	INGR. A.P. 5a Z 22 K9B/C 10 CR/E90	GEAR, 5TH (22T) MAINSHAFT
12	40432	1	INGR A.P. 3/4a Z 19/23	GEAR, 3/4TH (19-23T) MAINSHAFT
13	40451	1	INGR A.P. 6a Z 23	GEAR, 6TH (23T) MAINSHAFT
14	40423	1	INGR A.P. 2a Z 17	GEAR, 2ND (17T) MAINSHAFT
15	40460	1	ALBERO SECONDARIO	COUNTERSHAFT
16	19012	1	GABBIA A RULLI K 20X24X10	BUSH NEEDLE CAGE 20 X 24 X 10
17	40480	1	INGR A.S. 2a Z 29	GEAR, 2ND (29T) COUNTERSHAFT
18	12019	1	O RING PIGNONE CATENA	O-RING, DRIVE GEAR 2075
19	26002.1	1	DISTANZIALE PIGNONE (MOTO)	SPACER, MOTORCYCLE GEAR
20	04003	1	PARAOLIO PIGN.CATENA (26x37x7)	OIL SEAL 26 x 37 x 7
21	40015	1	PIGNONE Z 15 PASSO 1/2X5/16	SPROCKET 15T, DRIVE 1/2X5/16
21	40016	1	PIGNONE Z 16 PASSO 1/2X5/16	SPROCKET 16T, DRIVE 1/2X5/16
21	40017	1	PIGNONE Z 17 PASSO 1/2X5/16	SPROCKET 17T, DRIVE 1/2X5/16
22	40520	1	INGR A.S. 6a Z 23	GEAR, 6TH (23T) COUNTERSHAFT
23	49217	1	SEEGER E22 ANELLO ALB/S	CIRCLIP D.22 - COUNTERSHAFT
24	48011	2	RASAMENTO DENT.A/S 27X22X0,75	SPACER, 27x22x0,75
25	40500	1	INGR A.S. 4a Z 28	GEAR, 4TH (28T) COUNTERSHAFT
26	40490	1	INGR A.S. 3a Z 27	GEAR, 3RD (27T) COUNTERSHAFT



2T112MXJ23-M
MOTORE - ENGINE

CAMBIO
GEAR BOX

27	49217.1	1	SEEGER RETTIFICATO PER 40510	SEEGER RING FOR CODE 40510
28	40510	1	INGR A.S. 5a Z 24 CR/E 90	GEAR, 5TH (24T) COUNTERSHAFT
29	48012	1	RASAMENTO A/S M/M SPESS.0,5	SPACER, 26x17x0,5
30	19011	1	GABBIA A RULLI K 17X21X10	BUSH CAGE 17 X 21 X 10
31	40707	1	INGR A.S. 1a Z 32 CR/90	GEAR, 1ST(32T)COUNTERSH. MX/90
32	48010	1	RASAMENTO ALB/S.28X15X0,5 INGI	SPACER, 28x15x0,5
33	19071	1	GABBIA A 20X24X10 IN DUE META'	NEEDLE CAGE 20X24X10 TWO PIEC.



2T112MXJ23-M
MOTORE - ENGINE

VITI COPERCHI

10

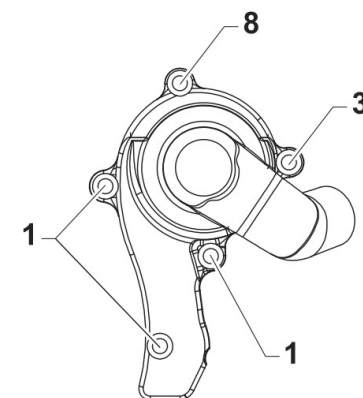
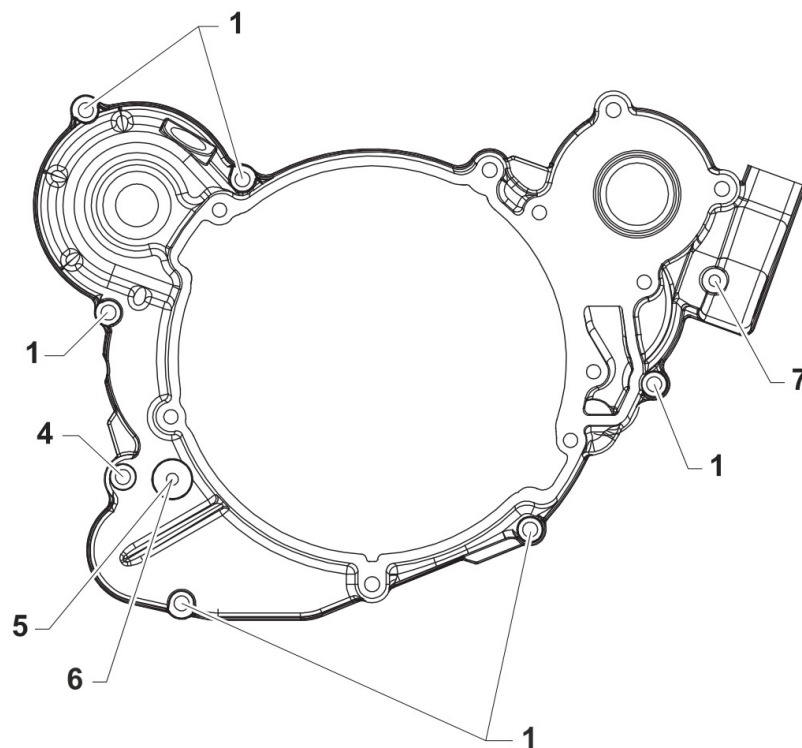
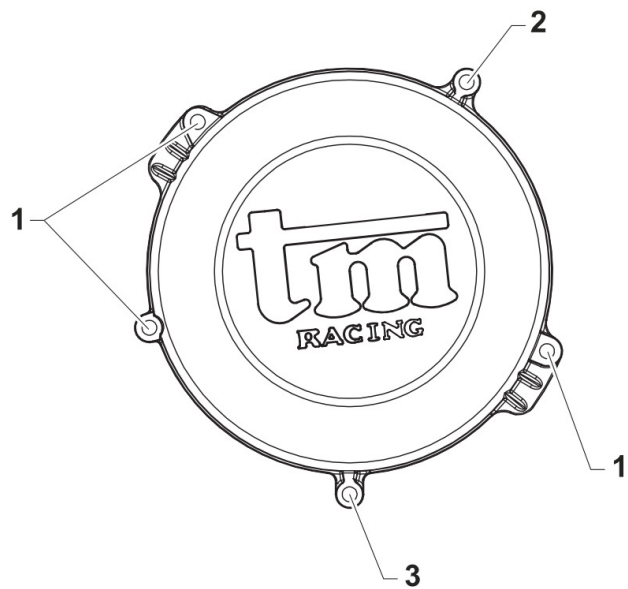

0704



2T112MXJ23-M
MOTORE - ENGINE

VITI COPERCHI

10

1	49476	12	VITE TCEI 5X20 UNI 5931	BOLT TCEI 5X20
2	49563	1	VITE TCEI 6X85	SCREW TCEI 6X85
3	49595	2	VITE TCEI 5X80 UNI 5931-912 Brun	BOLT TCEI 5X80
4	49477	1	VITE TCEI 5X25 UNI 5931-912 Brun	BOLT TCEI 5X25
5	49480	1	VITE TCEI 6X10 UNI 5931	BOLT TCEI 6X10
6	49104	1	RONDELLA 6 x 10 x 1,5 ALLUMINIO	WASHER 6 x 10 x 1.5 ALUMINUM
7	49593	1	VITE TCEI 4X8 U.	BOLT TCEI 4X8 U.
8	49986	1	VITE TCEI 5X75	BOLT TCEI 5 X 75



2T112MXJ23-M
MOTORE - ENGINE

VITI BASAMENTO

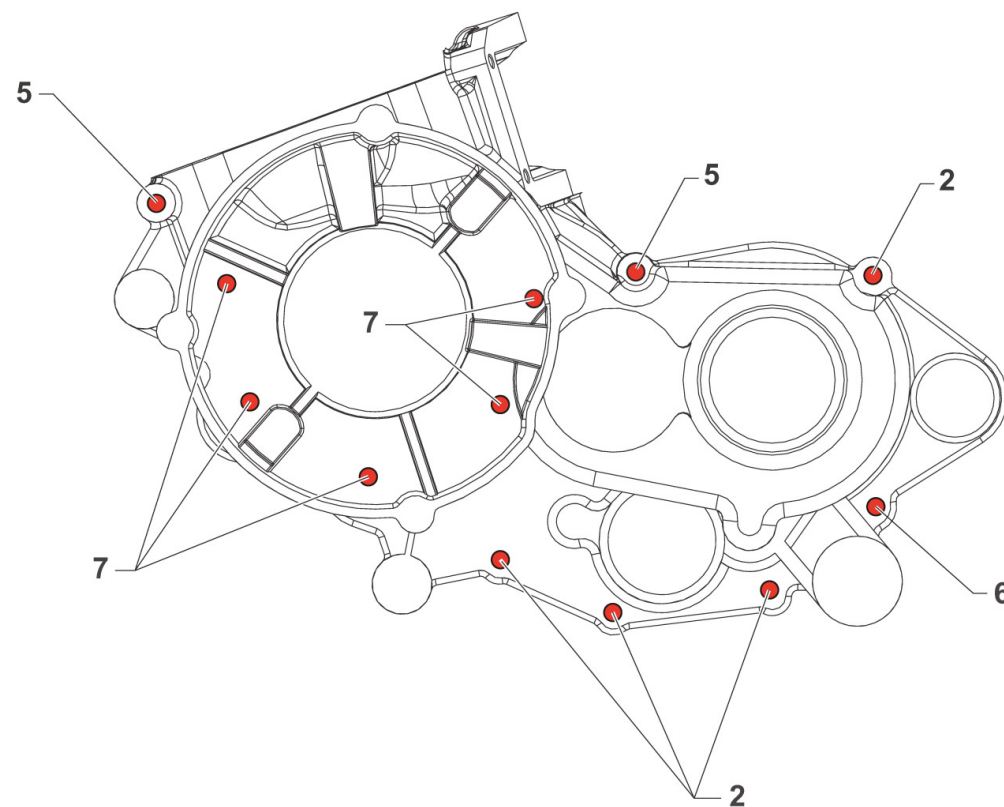
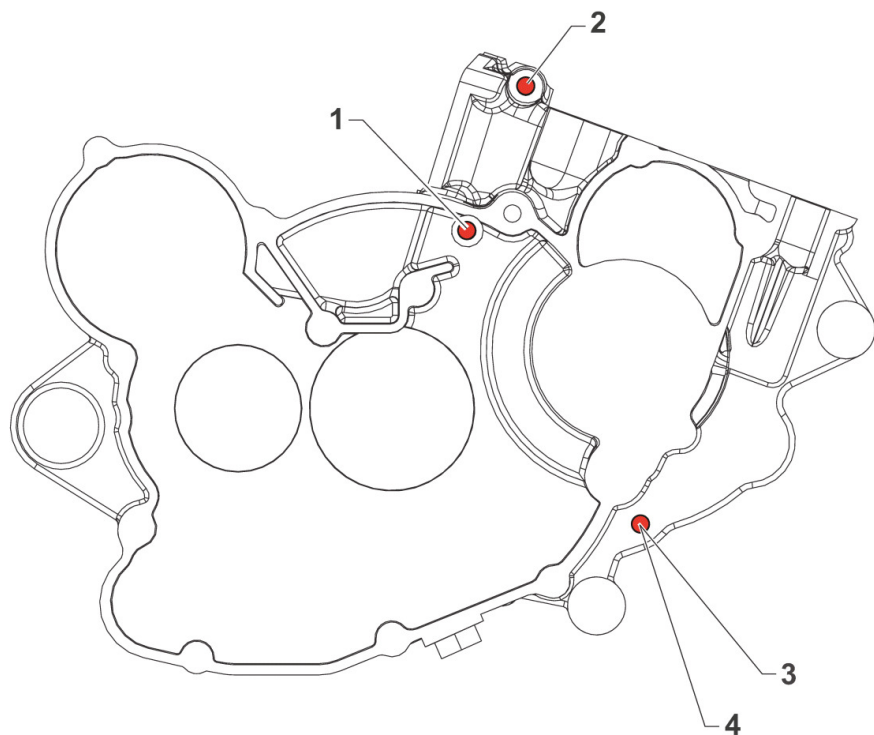



2T112MXJ23-M
MOTORE - ENGINE

VITI BASAMENTO

11

1	49491	1	VITE TCEI 6X55	BOLT TCEI 6X55
2	49409	5	VITE TSEI 6X35	
3	49104	1	RONDELLA 6 x 10 x 1,5 ALLUMINIO	WASHER 6 x 10 x 1.5 ALUMINUM
4	49480	1	VITE TCEI 6X10 UNI 5931	BOLT TCEI 6X10
5	49490	2	VITE TCEI 6X50 UNI 5931	BOLT TCEI 6X50
6	49488	1	VITE TCEI 6X40	BOLT TCEI 6x40
7	49489	5	VITE TCEI 6X45 UNI 5931	BOLT TCEI 6x45



2T112MXJ23-M
MOTORE - ENGINE

-

01126	2T112MXJ21-M-01	31	1
01139	2T112MXJ21-M-01	1	1
02031	2T112MXJ21-M-01	5	1
03010	2T8518-M-09	4	1
03011	2T8518-M-09	3	1
03012	2T8512-M-08	17	1
03014	2T112MXJ21-M-04	13	1
03020	2T112MXJ21-M-02	11	2
03025	2T112MXJ21-M-04	1	1
03028	2T112MXJ21-M-04	5	2
03080	2T8518-M-09	5	2
04003	2T8518-M-09	20	1
04004	2T8512-M-08	26	1
04005	2T8508-M-07	3	1
04006	2T112MXJ21-M-01	23	1
04017	2T112MXJ21-M-04	15	1
04035	2T112MXJ21-M-02	3	2
04037	2T112MXJ21-M-06	15	1
05262	2T112MXJ21-M-06	8	1
05509	2T8517-M-05	33	1
05516	2T112MXJ21-M-03	5	1
05526	2T112MXJ21-M-04	31	1
05527	2T112MXJ21-M-04	34	1
05528	2T112MXJ21-M-04	18	1
05537.20	2T112MXJ21-M-01	9	1
05537.30	2T112MXJ21-M-01	9	1
05537.40	2T112MXJ21-M-01	9	1
05537.50	2T112MXJ21-M-01	9	1

05627	2T112MXJ21-M-06	14	1
09020	2T112MXJ21-M-02	16	2
09021	2T112MXJ21-M-02	14	1
10027.95	2T112MXJ21-M-02	12	1
10027.96	2T112MXJ21-M-02	12	1
10027.97	2T112MXJ21-M-02	12	1
11060	2T112MXJ21-M-02	13	1
12003	2T112MXJ21-M-01	6	1
12019	2T8518-M-09	18	1
12021	2T112MXJ21-M-01	7	1
12259	2T8517-M-05	30	1
12260	2T8508-M-07	7	1
13089	2T112MXJ21-M-01	28	1
13095	2T112MXJ21-M-06	11	1
15206	2T112MXJ21-M-03	8	1
15209.112001	2T112MXJ21-M-03	11	1
15230	2T112MXJ21-M-03	1	1
16006	2T8508-M-07	16	1
16008	2T8508-M-07	5	1
16009	2T8512-M-08	6	1
16012	2T8512-M-08	13	2
16020	2T8517-M-05	2	5
16039	2T8508-M-07	9	1
16056	2T112MXJ21-M-04	9	1
16057	2T112MXJ21-M-01	24	1
16252	2T8512-M-08	22	1
17020	2T112MXJ21-M-02	10	1
18061	2T112MXJ21-M-02	7	2

18141	2T112MXJ21-M-02	18	2
18146	2T112MXJ21-M-02	9	1
18147	2T112MXJ21-M-02	6	1
18271	2T112MXJ21-M-02	8	1
18272	2T112MXJ21-M-02	5	1
18288	2T112MXJ21-M-02	4	1
19010	2T8508-M-07	13	1
19011	2T8518-M-09	30	1
19012	2T8518-M-09	16	1
19013	2T8517-M-05	21	2
19020	2T8517-M-05	6	1
19021	2T8517-M-05	5	1
19035	2T112MXJ21-M-02	15	1
19041	2T8512-M-08	31	1
19044	2T112MXJ21-M-04	27	1
19045	2T112MXJ21-M-01	19	2
19048	2T112MXJ21-M-04	25	1
19052	2T8517-M-05	32	1
19054	2T112MXJ21-M-04	3	4
19071	2T8518-M-09	33	1
19079	2T112MXJ21-M-01	18	1
20090	2T112MXJ21-M-06	10	1
20092	2T112MXJ21-M-06	9	1
21005	2T8517-M-05	18	6
22087	2T112MXJ21-M-01	17	1
25000	2T8517-M-05	17	1
25099.14	2T8517-M-05	13	1
26001	2T8517-M-05	7	1



2T112MXJ23-M
MOTORE - ENGINE

-

26002.1	2T8518-M-09	19	1
26005	2T8508-M-07	4	1
26006	2T8512-M-08	7	1
26007	2T8512-M-08	23	1
26021	2T8512-M-08	15	1
26022	2T8512-M-08	9	1
26023	2T8512-M-08	32	1
26041	2T112MXJ21-M-01	10	2
26043	2T112MXJ21-M-06	4	1
26044	2T112MXJ21-M-06	5	1
26050	2T8512-M-08	3	1
26051	2T8512-M-08	5	1
26060	2T8512-M-08	10	1
26061	2T8512-M-08	11	1
26062	2T8512-M-08	12	2
26063.12	2T8512-M-08	21	1
26212	2T8517-M-05	25	2
26254	2T8508-M-07	17	1
28004	2T112MXJ21-M-04	12	1
28004.85	2T112MXJ21-M-04	32	1
28005	2T112MXJ21-M-04	26	1
28009	2T112MXJ21-M-04	17	1
28026	2T112MXJ21-M-01	20	1
28039	2T112MXJ21-M-01	21	1
28043	2T112MXJ21-M-04	29	1
28044	2T112MXJ21-M-04	21	1
28051	2T8508-M-07	14	1
28100	2T8512-M-08	4	1

30186	2T112MXJ21-M-04	33	1
30187	2T112MXJ21-M-04	20	1
30194.112	2T112MXJ21-M-04	19	1
30205	2T8517-M-05	29	1
30206	2T8517-M-05	34	1
30211	2T112MXJ21-M-03	6	1
30296	2T112MXJ21-M-04	38	1
30297	2T112MXJ21-M-06	16	1
33004	2T8512-M-08	20	1
33016	2T8512-M-08	30	1
33255	2T8512-M-08	29	1
33256	2T8512-M-08	18	1
35012	2T8517-M-05	10	8
35015	2T8517-M-05	4	1
35019	2T8517-M-05	9	7
35025	2T8517-M-05	8	1
35026	2T8517-M-05	16	1
35043	2T8517-M-05	22	1
35125	2T8517-M-05	31	1
35264	2T8517-M-05	28	1
40003	2T8518-M-09	1	1
40004	2T8518-M-09	2	1
40015	2T8518-M-09	21	1
40016	2T8518-M-09	21	1
40017	2T8518-M-09	21	1
40022	2T8517-M-05	27	1
40029	2T8517-M-05	26	1
40055	2T112MXJ21-M-02	2	1

40056	2T112MXJ21-M-04	2	1
40059	2T112MXJ21-M-04	7	1
40065	2T112MXJ21-M-04	4	1
40310	2T8512-M-08	14	1
40350	2T8508-M-07	15	1
40351	2T8508-M-07	20	1
40400	2T8517-M-05	19	1
40404	2T8517-M-05	20	1
40423	2T8518-M-09	14	1
40432	2T8518-M-09	12	1
40440	2T8518-M-09	11	1
40451	2T8518-M-09	13	1
40460	2T8518-M-09	15	1
40480	2T8518-M-09	17	1
40490	2T8518-M-09	26	1
40500	2T8518-M-09	25	1
40510	2T8518-M-09	28	1
40520	2T8518-M-09	22	1
40707	2T8518-M-09	31	1
40713.85	2T8518-M-09	10	1
43038	2T8508-M-07	1	1
43039.01	2T8508-M-07	8	1
43048	2T8512-M-08	27	1
43250.03	2T8508-M-07	10	1
48002	2T8517-M-05	14	1
48003	2T8517-M-05	23	1
48004	2T8508-M-07	19	2
48008	2T8508-M-07	12	1



2T112MXJ23-M
MOTORE - ENGINE

-

48010	2T8518-M-09	32	1
48011	2T8518-M-09	24	2
48012	2T8518-M-09	29	1
48013	2T8518-M-09	9	3
48024	2T112MXJ21-M-04	10	1
48031	2T112MXJ21-M-04	8	1
48041	2T8518-M-09	6	1
49002	2T112MXJ21-M-06	3	1
49010	2T112MXJ21-M-02	17	1
49041	2T112MXJ21-M-04	23	2
49042	2T112MXJ21-M-04	24	2
49043	2T112MXJ21-M-06	2	4
49052	2T8517-M-05	11	1
49056	2T112MXJ21-M-02	1	1
	2T112MXJ21-M-03	4	1
49058	2T8517-M-05	1	5
49103	2T112MXJ21-M-04	35	1
	2T112MXJ21-M-06	6	1
49104	2T112MXJ-M-10	6	1
	2T8508-M-11	3	1
49127	2T8517-M-05	12	1
49189	2T112MXJ21-M-01	8	2
49211	2T8517-M-05	3	1
49212	2T8512-M-08	28	1
49214	2T8508-M-07	18	1
49215	2T112MXJ21-M-04	14	1
49216	2T8518-M-09	8	4
49217	2T8518-M-09	23	1

49217.1	2T8518-M-09	27	1
49222	2T8518-M-09	7	1
49263	2T112MXJ21-M-04	6	1
49300	2T112MXJ21-M-04	36	1
49301	2T112MXJ21-M-06	7	1
49317	2T112MXJ21-M-03	15	2
49355	2T112MXJ21-M-01	27	2
49357	2T112MXJ21-M-01	4	6
	2T112MXJ21-M-03	9	2
49368	2T8508-M-07	2	1
49401	2T112MXJ21-M-01	12	1
49402	2T112MXJ21-M-01	15	2
49403U	2T112MXJ21-M-02	19	4
49405	2T8512-M-08	8	2
49406	2T8508-M-07	6	1
49409	2T8508-M-11	2	5
49440	2T8512-M-08	33	2
49472	2T112MXJ21-M-04	37	3
49476	2T112MXJ-M-10	1	12
49477	2T112MXJ-M-10	4	1
	2T112MXJ21-M-03	7	4
49480	2T112MXJ-M-10	5	1
	2T8508-M-11	4	1
49483	2T8512-M-08	16	2
49484	2T112MXJ21-M-03	3	2
	2T112MXJ21-M-06	12	4
49485	2T8512-M-08	25	1
49486	2T8517-M-05	24	2

49488	2T8508-M-11	6	1
49489	2T8508-M-11	7	5
49490	2T8508-M-11	5	2
49491	2T8508-M-11	1	1
49563	2T112MXJ-M-10	2	1
49593	2T112MXJ-M-10	7	1
49595	2T112MXJ-M-10	3	2
49603	2T112MXJ21-M-03	10	2
	2T8512-M-08	2	1
49630	2T112MXJ21-M-04	22	2
49630.3	2T112MXJ21-M-01	16	2
49633	2T112MXJ21-M-03	14	2
49638	2T8512-M-08	1	1
49640	2T112MXJ21-M-06	1	4
49689	2T112MXJ21-M-04	16	1
49701	2T112MXJ21-M-01	22	1
	2T112MXJ21-M-04	30	1
49727	2T8517-M-05	15	6
49902	2T112MXJ21-M-03	2	2
49986	2T112MXJ-M-10	8	1
50124	2T8517-M-05	13	1
51063	2T112MXJ21-M-06	13	1
68120	2T112MXJ21-M-03	16	1
F04354	2T112MXJ21-M-04	28	1
F06105	2T112MXJ21-M-01	3	1
F15562	2T112MXJ21-M-03	12	1
F19503	2T112MXJ21-M-04	11	1
F21418	2T112MXJ21-M-01	2	1



2T112MXJ23-M
MOTORE - ENGINE

-

F26537	2T112MXJ21-M-03	13	1
F33314	2T8512-M-08	19	2