



USES AND
RACOMMENDS



www.tmracing.it

TM Racing SpA - Via Fano, 6
61122 Pesaro - ITALY
Phone: +39 0721 25113

4T300FIMX23-M

MOTORE
ENGINE

24/02/2023



INFORMAZIONI GENERALI

Il presente catalogo serve per richiedere con esattezza le parti di ricambio.

Nelle ordinazioni indicare:

1) Il numero di matricola del Telaio che è stampigliato sul lato destro del canotto di sterzo. Nei modelli EN, SMR, SMR il numero di matricola è riportato anche su una targhetta posta sul lato sinistro (Vedi foto).

2) il numero di serie del Motore. E' posto sulla sinistra del motore tra la leva cambio e i coperchio accensione (Vedi foto).

3) Il codice dei particolari seguito dalla descrizione.

4) Il colore per i pezzi verniciati o comunque colorati.

Le indicazioni destra e sinistra si riferiscono ai lati del veicolo rispetto al senso di marcia.

Foto e disegni sono solo a scopo informativo e potrebbero non corrispondere esattamente alle caratteristiche dei prodotti.

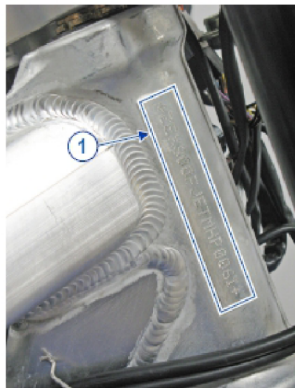

GENERAL INFORMATION

The present spare parts catalogue enables one to order exactly the right spare part.

When ordering specify:

1) The frame serial number. It is embossed on the right side of the steering metal tube. In the EN, SMR and SMR models, the serial number is also stated on a plate positioned on the left hand side (See photo).

2) The engine serial numer. It is located on the left side of the engine between the gear lever and the ignition cover (See photo).

3) The part's code number followed but its description.

4) Indicate colour for painted or colored parts.

References to right and left apply to the vehicle in terms of its direction of movement.

Photos and drawings are for informational purposes only and may not exactly match the characteristics of the products.

NOTE – LEGENDA

MY

NOVITA' INTRODOTTA DIFFERENTE O NON PRESENTE NEL MODELLO DELL'ANNO PRECEDENTE

PART DIFFERENT OR NOT PRESENT IN THE REVIOUS YEAR MODEL

5M

MOTORE CON CAMBIO A 5 MARCE
ENGINE WITH 5 GEARS SPEED

6M

MOTORE CON CAMBIO A 6 MARCE
ENGINE WITH 6 GEARS SPEED

KS

MOTORE CON SOLO KICK STARTER
ENGINE WITH KICK STARTER ONLY

ES

MOTORE CON AVVIAMENTO ELETTRICO
ENGINE WITH ELECTRIC STARTER

X

RICAMBIO NON DISPONIBILE ALLA VENDITA
PART CAN NOT BE SOLD SEPARATELY

Le illustrazioni riportate in questo manuale sono fornite solo come riferimento e possono variare dal prodotto effettivo,

Dati indicativi soggetti a modifiche senza impegno di preavviso.

The illustrations in this manual are for reference only and may vary from the actual product.

All data are subject to modification without prior notice.



4T300FIMX23-M
MOTORE - ENGINE

CILINDRO - PISTONE - CYLINDER - PISTON.....	4
TESTA - HEAD.....	6
ALBERO MOTORE - CRANKSHAFT.....	9
DISTRIBUZIONE - DISTRIBUTION.....	11
LUBRIFICAZIONE - LUBRICATION.....	14
CARTER MOTORE - CLUTCH CASE.....	17
FRIZIONE - CLUTCH.....	19
COMANDO CAMBIO - GEARSHIFT MECHANISM.....	22
CAMBIO - GEAR BOX.....	25
CENTRIFUGATORE AVVIAMENTO.....	28
ACCENSIONE ES - IGNITION ES.....	30
-	33



4T300FIMX23-M
MOTORE - ENGINE

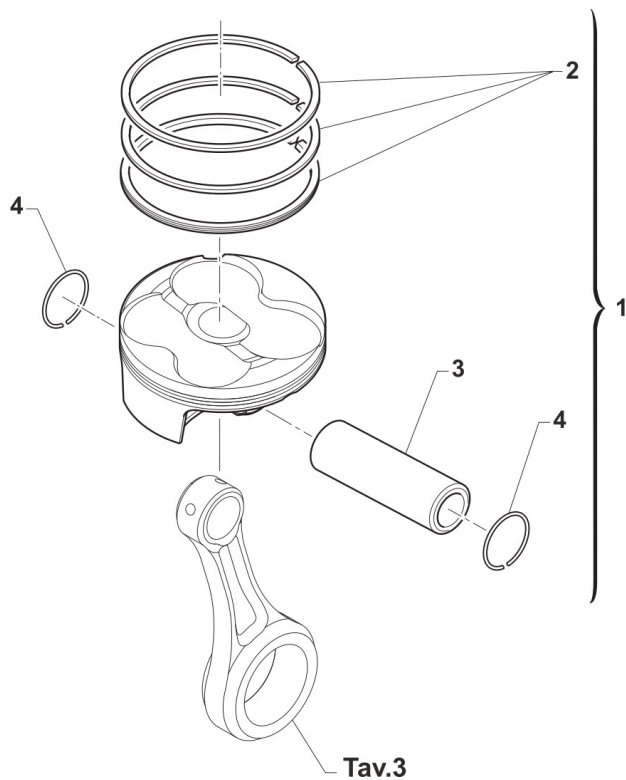

CILINDRO - PISTONE
CYLINDER - PISTON

1

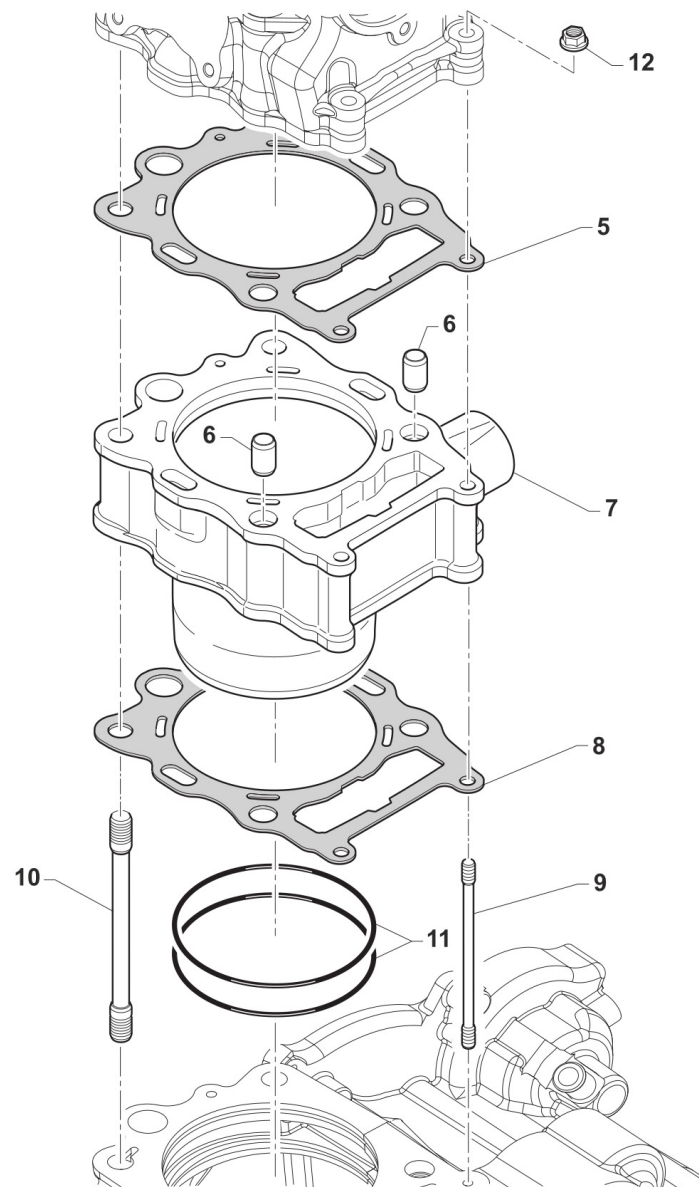

TM0001



4T300FIMX23-M
MOTORE - ENGINE

CILINDRO - PISTONE
CYLINDER - PISTON

1

1	F10868.95	1	PISTONE Ø 80,95 C.19,3 300 4T Fi Twin CPL	PISTON Ø 80,95 C.19,3 300 F.S.TWIN Fi ASSY
1	F10868.96	1	PISTONE Ø 80,96 C.19,3 300 Fi Twin CPL	
1	F10868.97	1	PISTONE Ø 80,97 C.19,3 300 Fi Twin CPL	
1	F10868.98	1	PISTONE Ø 80,98 C.19,3 300 Fi Twin CPL	
2	F11409	1	KIT SEGMENTI D.81 NPR	RINGS KIT D.81 NPR
3	F09396.2	1	SPINOTTO 16X10.5X36 BIC.DLC S2	PISTON PIN 16X10.5X36 DLC
4	F09385	2	ANELLINO D.16X1 VP	CIRCLIP D. 16X1 VP
5	F05859.1	1	HEAD GASKET D. 81 3 LAYERS CH	
6	F26428	2	GRANO RIFERIMENTO 12X13 F10.2	GRUB SCREW 12X13 H.10,2mm
7	F01729	1	Cilindro Ø81 h=34,8 mm 300 REPLICA	
8	F05856.1	1	GUARNIZ.CIL/BAS SP.0,2 EVO3 M3	GASKET CYL. TH.0,2 EVO3 M3
8	F05856.2	1	GUARNIZ.CIL/BAS SP.0,3 EVO3 M3	GASKET CYL. TH.0,3 EVO3 M3
8	F05856.3	1	GUARNIZ.CIL/BAS SP.0,4 EVO3 M3	GASKET CYL TH.0,4 EVO3 M3
8	F05856.4	1	GUARNIZ.CIL/BAS SP.0,5 EVO3 M3	GASKET CYL. TH.0,5 EVO3 M3
9	F49875	2	PRIGIONIERO M6X1 /=83 MM A10.9	STUD M 6X1 83MM
10	F49045	4	PRIGIONIERO M10X1,25 L=142,5	STUD M 10X1,25 142,5 MM
11	F12357.1	2	O RING ORM 91,0X2,0 VITON	
12	49676	2	DADO M 6X1 FLANG. AUTOBL.ACC.	NUT, FLANGED M6 X 1 S.B.

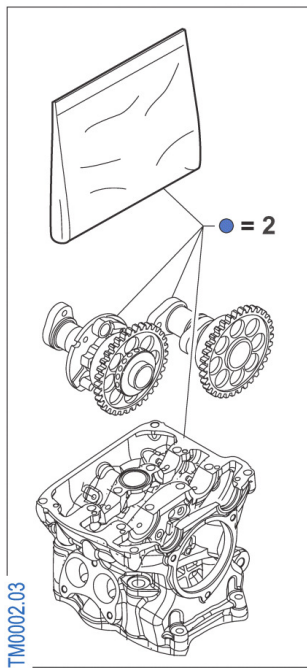
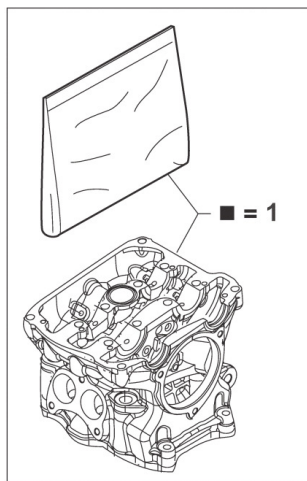

TM0002.03

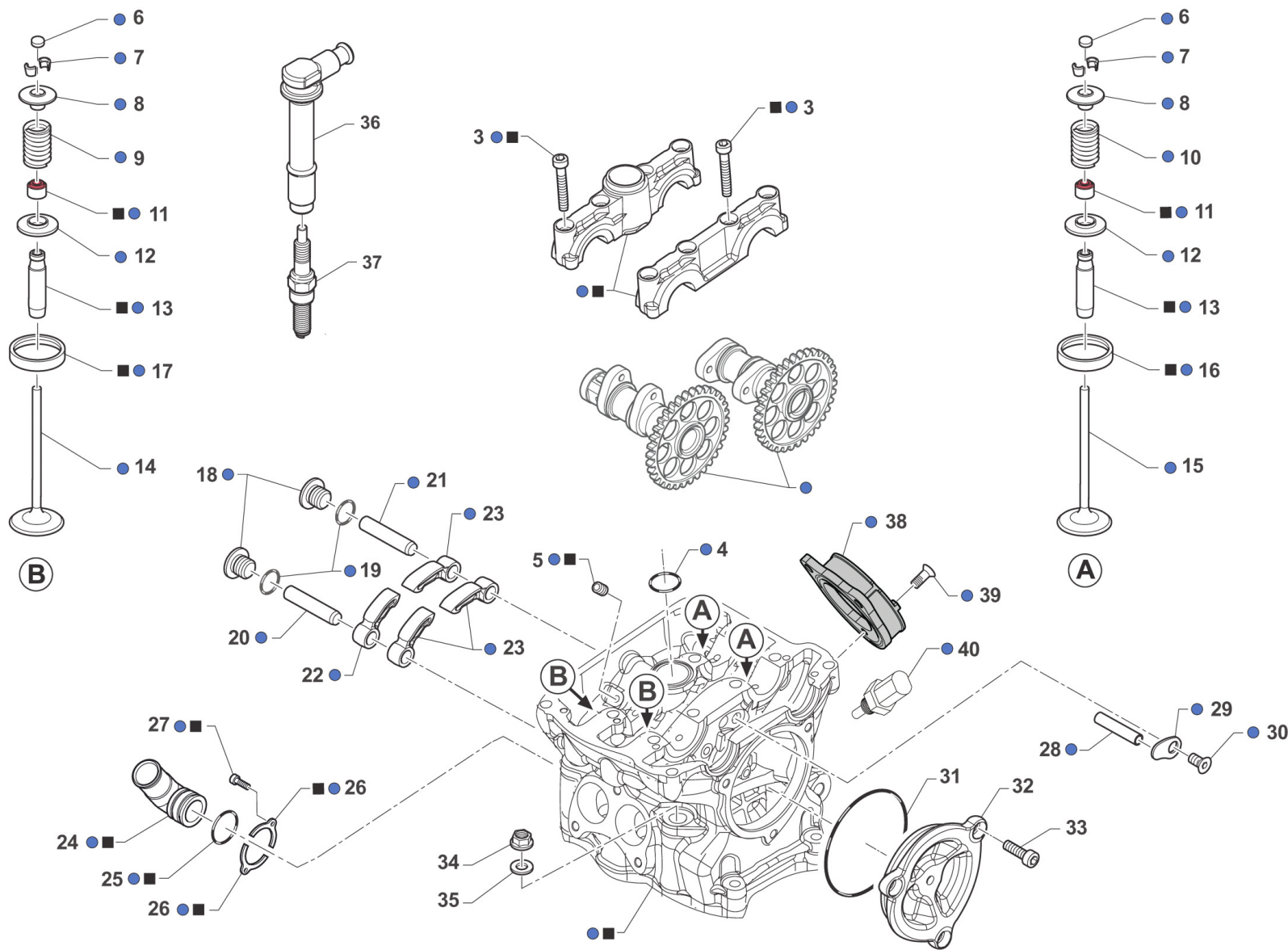



4T300FIMX23-M
MOTORE - ENGINE

TESTA
HEAD

1	F02886	1	TESTA 4T 250/300 Fi TWIN SEMI-CPL	
2	F02887	1	TESTA 250Fi TWIN MX ES 18/21 CPL 300Fi TWIN MX ES 20/22 CPL	CYLINDER HEAD 250Fi F.S. MX M18->
3	49487	8	VITE TCEI 6X35 UNI 5931	BOLT TCEI 6X35
4	F12345.1	1	O RING ORM 24,0X1,5 VITON	O-RING 24 X 1,5
5	49702	1	GRANO 5X 6 VALV.SC.MARTELLETTO	GRUB SCREW 5 X 6 INLET VALVE
6	F26603.255	1	PASTIGLIA REGOLAZ. GIOCO Ø 7,26 Sp. 2,55	SHIM, VALVE ADJUSTING Ø 7,26 TH. 2,55
6	F26603.260	1	PASTIGLIA REGOLAZ. GIOCO Ø 7,26 Sp. 2,60	SHIM, VALVE ADJUSTING Ø 7,26 TH. 2,60
6	F26603.265	1	PASTIGLIA REGOLAZ. GIOCO Ø 7,26 Sp. 2,65	SHIM, VALVE ADJUSTING Ø 7,26 TH. 2,65
6	F26603.270	1	PASTIGLIA REGOLAZ. GIOCO Ø 7,26 Sp. 2,70	SHIM, VALVE ADJUSTING Ø 7,26 TH. 2,70
6	F26603.275	1	PASTIGLIA REGOLAZ. GIOCO Ø 7,26 Sp. 2,75	SHIM, VALVE ADJUSTING Ø 7,26 TH. 2,75
6	F26603.280	1	PASTIGLIA REGOLAZ. GIOCO Ø 7,26 Sp. 2,80	SHIM, VALVE ADJUSTING Ø 7,26 TH. 2,80
6	F26603.285	1	PASTIGLIA REGOLAZ. GIOCO Ø 7,26 Sp. 2,85	SHIM, VALVE ADJUSTING Ø 7,26 TH. 2,85
6	F26603.290	1	PASTIGLIA REGOLAZ. GIOCO Ø 7,26 Sp. 2,90	SHIM, VALVE ADJUSTING Ø 7,26 TH. 2,90
6	F26603.295	1	PASTIGLIA REGOLAZ. GIOCO Ø 7,26 Sp. 2,95	SHIM, VALVE ADJUSTING Ø 7,26 TH. 2,95
6	F26603.300	1	PASTIGLIA REGOLAZ. GIOCO Ø 7,26 Sp. 3,00	SHIM, VALVE ADJUSTING Ø 7,26 TH. 3,00
6	F26603.305	1	PASTIGLIA REGOLAZ. GIOCO Ø 7,26 Sp. 3,05	SHIM, VALVE ADJUSTING Ø 7,26 TH. 3,05
6	F26603.310	1	PASTIGLIA REGOLAZ. GIOCO Ø 7,26 Sp. 3,10	SHIM, VALVE ADJUSTING Ø 7,26 TH. 3,10
6	F26603.315	1	PASTIGLIA REGOLAZ. GIOCO Ø 7,26 Sp. 3,15	SHIM, VALVE ADJUSTING 7,26 TH. 3,15
6	F26603.320	1	PASTIGLIA REGOLAZ. GIOCO Ø 7,26 Sp. 3,20	SHIM, VALVE ADJUSTING 7,26 TH. 3,20
7	F14178	8	SEMICONO D.5 - 15 [^] HAYFIELD	VALVE RETAINER D.5 15 [^] HAYFIELD
8	F26597	4	PIATTELLO SUP. MOLLA 250M3	UPPER PLATE
9	F16473	2	SET MOLLA EST. + MOLLA INT. SCAR.	EXTER. & INTER.SPRINGS EXHAUST
10	F16472	2	SET MOLLA EST. + MOLLA INT. ASP.	EXTER. & INTER.SPRINGS INLET
11	F04388	4	ANELLO TENUTA STELO VALV.D.5mm SKF	
12	F26689	4	PIATTELLO T 24X4	LOWER PLATE
13	F26728.1	4	GUIDA VALVOLA SINT. D.5 PER TENUTA SKF BLV077	
14	F14158	2	VALVOLA SCA 250Fi 26.8x5 TIT	EXHAUST VALVE 250Fi TIT 26.8X5
15	F14164	2	VALVOLA ASP 250Fi 32x5 TIT	INLET VALVE d.35X5 250Fi TIT



4T300FIMX23-M
MOTORE - ENGINE

TESTA
HEAD

2

16	F26557	2	SEDE VALVOLA ASP.250cc	
17	F26558	2	SEDE VALVOLA SCAR.250cc	
18	F49871	2	TAPPO ASSE ROT.BILANC.250 M3	PLUG
19	F12325	2	OR ORM 090-15 FILTRO ASP.OLIO 250N	O-RING
20	F28812	1	ASSE ROTAZIONE BIL.SCAR. 250M3	AXLE, ROCKER ARM EXHAUST
21	F28811	1	ASSE ROTAZIONE BIL.ASP.250M3LO	AXLE, ROCKER ARM INTAKE
22	F28836	1	FINGER FOLLOWER WITH DECOM.MIM	FINGER FOLLOWER WITH DECOM.MIM
23	F28835	3	FINGER FOLLOWER NO DECOMP. MIM	FINGER FOLLOWER NO DECOMP. MIM
24	F28841	1	RACCORDO USCITA ACQUA TESTA	JOINT, HEAD WATER
25	F12346.1	1	O RING ORM 18,0X2,0 VITON	O-RING 18 X 2
26	F48374	2	PIASTRINO RITEGNO RACCORDO H2O	PLATE
27	49553	2	VITE TCEI 4X8 5931-912 Brun	BOLT TCEI 4X8
28	F28810	1	ASSE ROTAZIONE BIL.ASP.250M3LC	AXLE, ROCKER ARM INTAKE
29	F48371	1	PIASTRINO BATT.ASSE ROT.BIL.LC	PLATE
30	49396	1	VITE TSEI 5X10	BOLT TSEI 5X10
31	F12351.1	1	O RING ORM 61,6X2,4 VITON	O-RING 61,6 X 2,4
32	F30015	1	COPERCHIO ISP. TESTA 250Fi 250 REP.4T	COVER, HEAD, TWIN
33	49481	3	VITE TCEI 6X12	BOLT TCEI 6X12
34	F49874	4	DADO M 10 X 1,25 CH 12 FLANGIATO	NUT FLANGED M 10x1,25 T.12mm
35	F48400	4	RONDELLA Ø10xØ17,5x3	WASHER Ø10xØ17,5x3
36	F21436	1	PIPETTA CANDELA RESISTIVA 250 4T MY18->	CAP, SPARK PLUG
37	F06116	1	CANDELA NGK R0451B-8	SPARK PLUG NGK R0451B-8
38	F13287	1	COLLETTORE ASPIRAZIONE 250Fi 4T REPL.	INLET MANIFOLD 250Fi F.S. R.
39	49989	3	VITE TS 5X14 TORX	BOLT TORX 5 X 14
40	F08003	1	SENSORE TEMP. ACQUA 4T	SENSOR, WATER TEMPERATURE



4T300FIMX23-M
MOTORE - ENGINE

ALBERO MOTORE
CRANKSHAFT

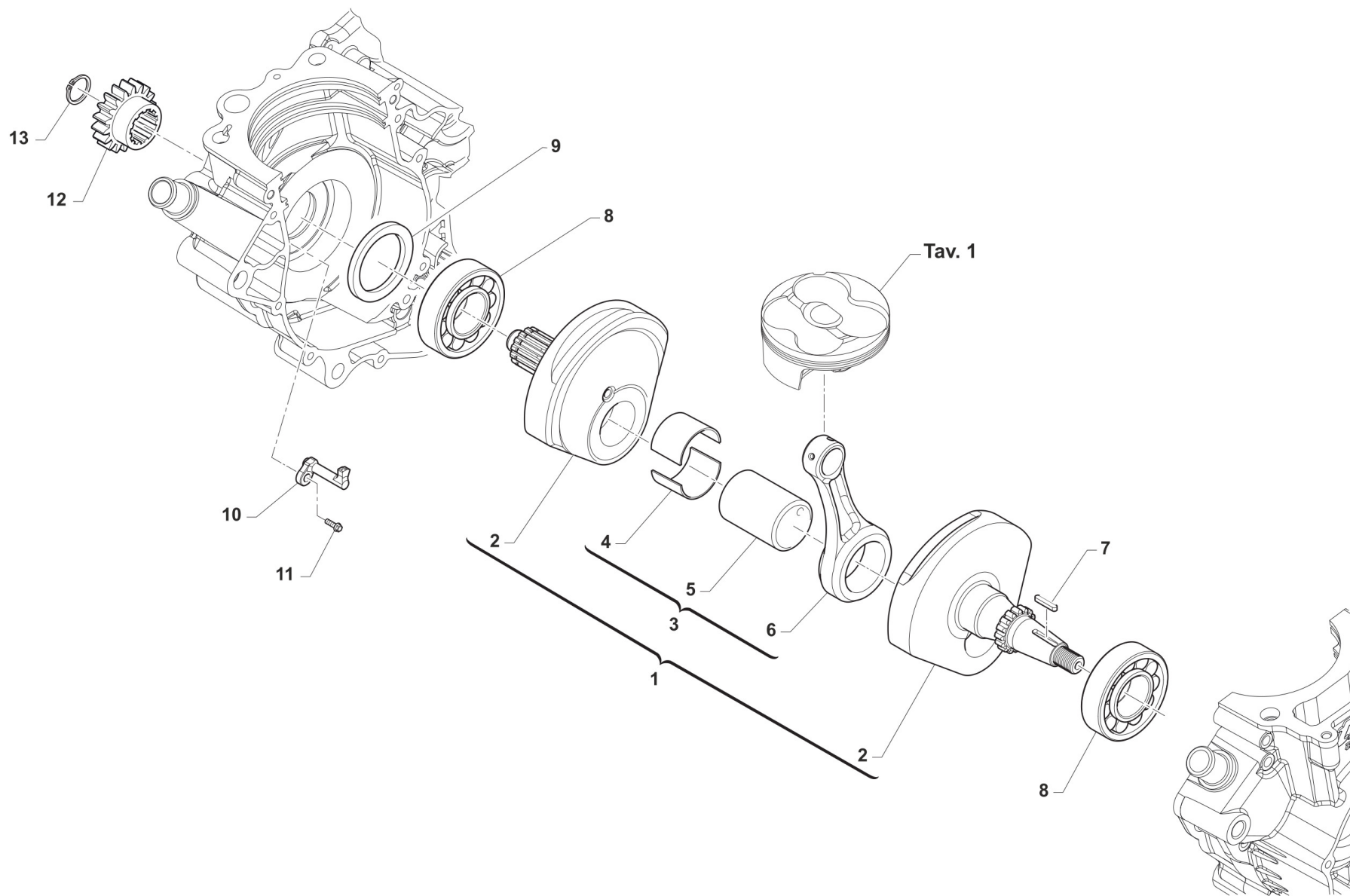

TM0003



4T300FIMX23-M
MOTORE - ENGINE

ALBERO MOTORE
CRANKSHAFT

3

1	F18125	1	ALBERO MOTORE 300 FI E.S. 2020 CPL	
2	F18127	1	COPPIA SEMI ALBERI 300 FI E.S. 2020	
3	F18123	1	BIELLA 300FI REPLICA MX/EN CPL (D.34XD.17,8 INTERASSE 98,5)	
4	F03375.4	1	BRONZINA CP BIELLA 30X34X18 BB BLU/BLU	CONNECTING ROD BUSH ASSY 30x34x18 blu
4	F03375.5	1	BRONZINA CP BIELLA 30X34X18 RG ROSSO/GIALLO	BUSH ASSY 30x34x18 RED/YELLOW
5	F18059	1	ASSE ACCOPP. D.30X54,7 X BRONZ	
6	F18104	1	BIELLA D34XD.16 I.98,5 BR	
7	F49853	1	CHIAVETTA 5X3X25 UNI7510R.F.A.	WOODRUFF KEY, 5x3x25
8	03026	2	CUSCINETTO ALBERO MOTORE NJ206	BUSH, NJ206 CRANKSHAFT
9	F04375	1	PARAOLIO 25X35X4	
10	F32573	1	UGELLO RAFFREDDAMENTO	NOZZLE
11	49472	1	VITE TCEI 5X12 UNI 5931-912 Brun	BOLT TCEI 5X12
12	F40158	1	PIGNONE TRASM.PRIMARIA Z20 SCANAL.	
13	49255	1	SEEGER RETTIFICATO CAMBIO 250	CIRCLIP, GEAR BOX 250cc

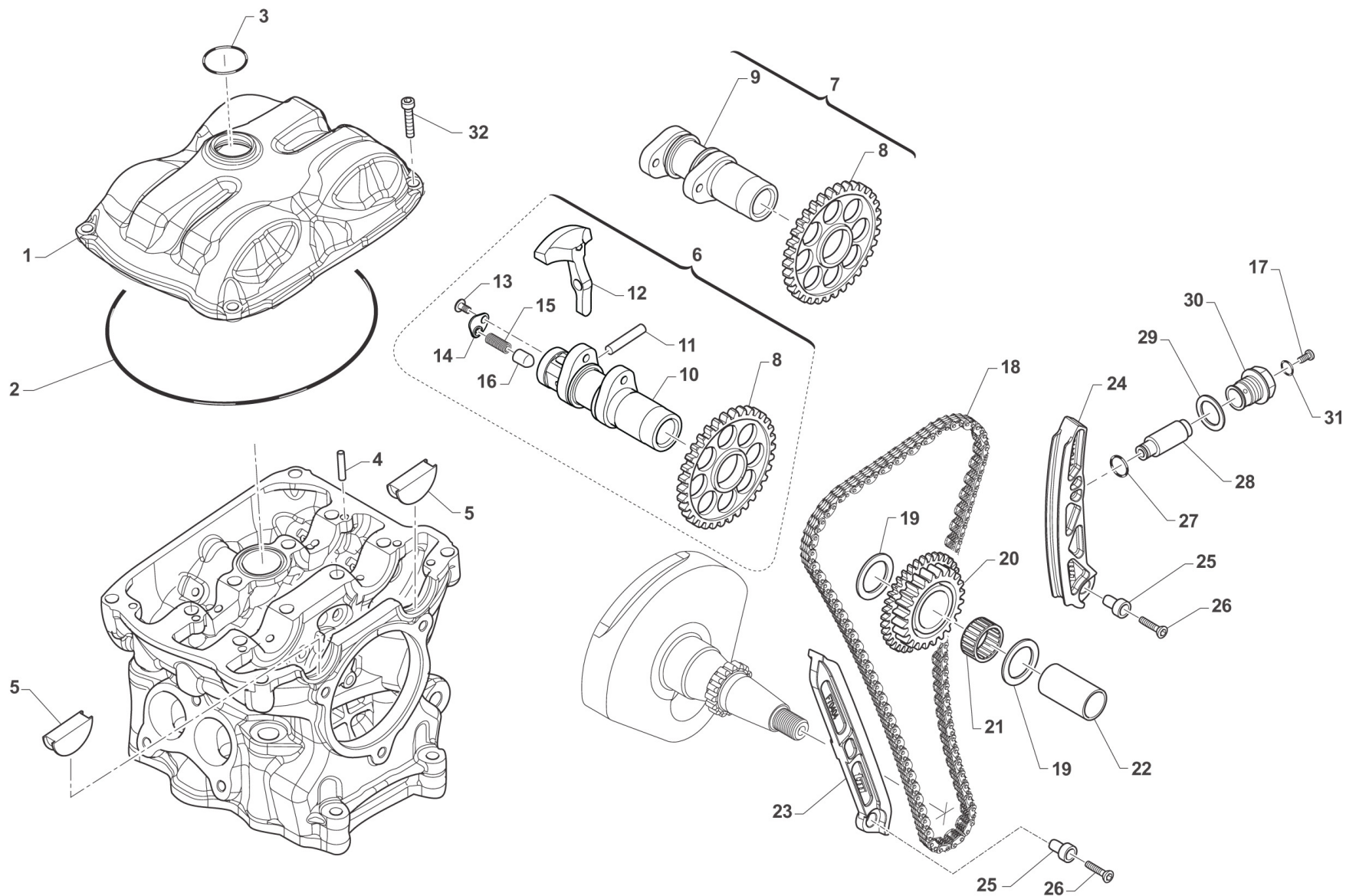

TM0004.01



4T300FIMX23-M
MOTORE - ENGINE

DISTRIBUZIONE
DISTRIBUTION

4

1	F30061	8	COPERCHIO TESTA 250Fi MX MY18	CYLINDER HEAD COVER 250Fi F.S. MX M18->
2	F12364	1	O RING 155X2	O-RING 155 X 2
3	F12344.1	1	O RING ORM 23,0X1,5 VITON	O-RING 23 X 1,5
4	F19529	4	RULLO D.4 X 10 TESTA BOMBATA" NRA"	PIN 4 X 10
5	F30060	2	COPERC.TTO FORI A.CAMME250/300	CAP, HOLE CAMSHAFT 250/300
6	F28852	1	ALBERO A CAMME SCARICO 250Fi MX ES + EN CPL	CAMSHAFT ASSY, EX, 250 MX ES + EN
7	F28846	1	ALBERO A CAMME ASPIRAZIONE 250Fi MX 2018 CPL	
8	F40062	2	INGR. ALBERO A CAMME GEN. Z28	GEAR 28T, CAMSHAFT
9	F28807	1	ALBERO A CAMME ASP. EVO3 XA-18	
10	F28809	1	ALBERO A CAMME SCAR.EVO3 XS-04	CAMSHAFT EX XS-04
11	F19530	1	RULLO D.5 X 19.8 G2 0 -0.010	PIN 5 X 19,8
12	F26575	1	DECOMPRESSORE (MASSA CENT.) M3	DECOMPRESSOR
13	49597	1	VITE TBCEI 4 x 8 UNI 7380	BOLT TBCE 4 x 8
14	F48368	1	PIASTRINO GUIDA MOLLA DECOMPR.	PLATE DECOMPRESSOR SPRING 250 F.S.
15	F16479	1	MOLLA DECOMP. FILO Ø 0,3 250/300 4T TWIN	SPRING
16	F26576	1	PISTONCINO ATTIVAZIONE DECOMP.	PISTON DECOMPRESSOR
17	F49871	1	TAPPO ASSE ROT.BILANC.250 M3	PLUG
18	F70423	1	CATENA DIST.MORSE 92RH2015 92P 300 TWIN	CAM CHAIN 92RH2015 92 300 TWIN
19	F48372	2	RASAMENTO 18 x 30 x 0.8	SHIM 18 X 30 X 0,8
20	F40061	1	INGR. DOPPIO DISTRIBUZ.24/21	GEAR 24/21T DISTRIBUTION
21	F19526	1	GABBIA A RULLINI K 18X22X17	NEEDLE BUSH 18x22x17
22	F28813	1	ASSE ROTAZIONE INTR.18X42,7F13	PIN ROTATION GEAR 18x42,7 H.13
23	F70404	1	PATTINO FISSO 4T 250/300 TWIN	FIXED SLIDER
24	F70413	1	PATTINO MOBILE 4T 250/300 TWIN	MOVING SLIDER
25	F49883	2	BOCCOLA FISS. PATT.MOB. F70402	BUSH
26	49406	2	VITE TSEI 6X20	BOLT TSEI 6x20
27	F12346.1	1	O RING ORM 18,0X2,0 VITON	O-RING 18 X 2
28	F70408	1	TENDITORE IDRAULICO 250 M3 F-346264.89-0100.KSH.KSYS	HYDRAULIC TENSIONER 250Fi M3



4T300FIMX23-M
MOTORE - ENGINE

DISTRIBUZIONE
DISTRIBUTION

4

29	49949	1	RONDELLA RAME 24X30X1,5	WASHER, COPPER, 24 X 30 X 1,5
30	F49884	1	TAPPO TENSIONATORE IDR. M3	PLUG, TENSIONER
31	F12356.1	1	O RING ORM 10,0X1,0 VITON	O-RING 10 X 1
32	49482	4	VITE TCEI 6X14 UNI 5931	BOLT TCEI 6X14

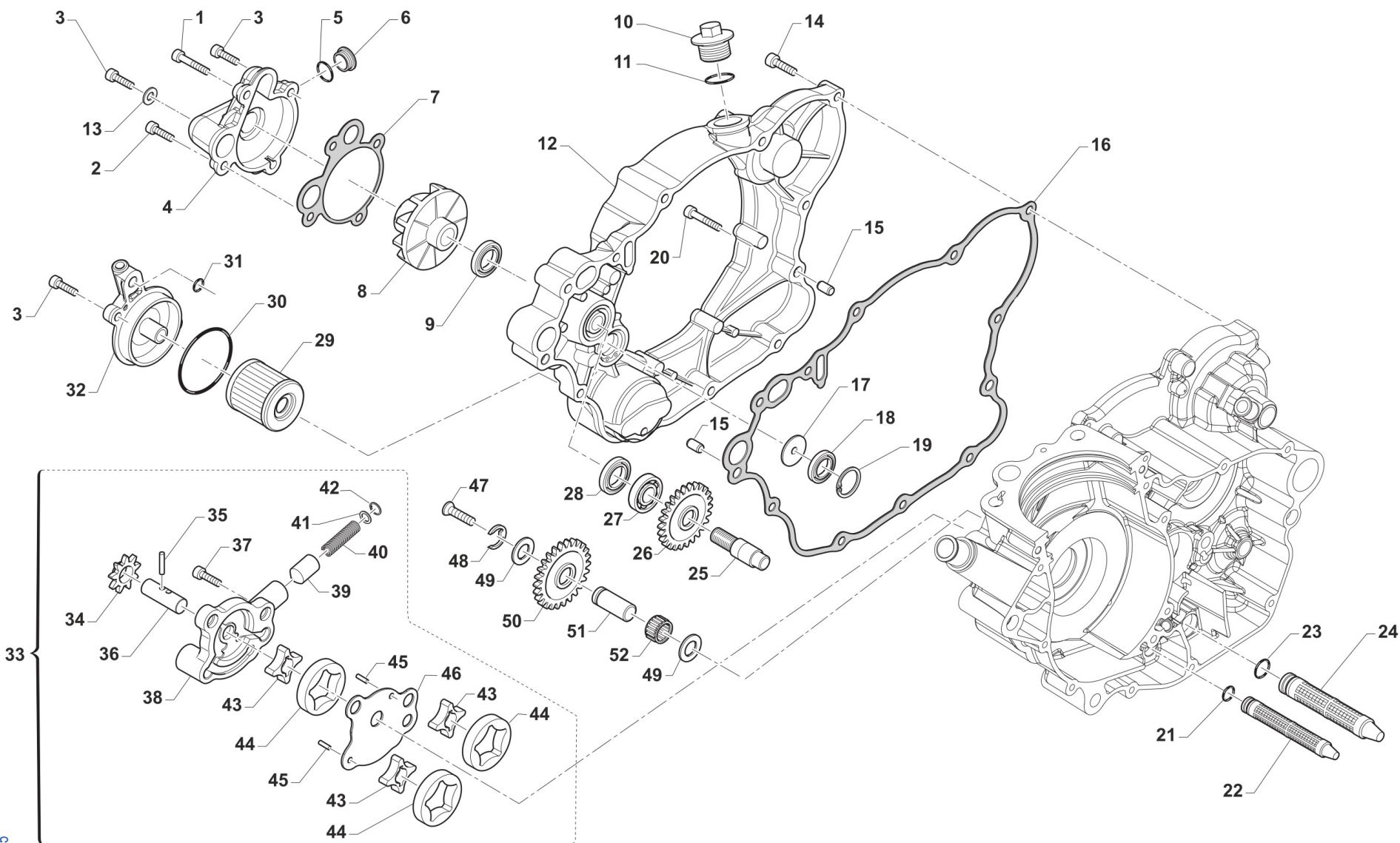

TM0005



4T300FIMX23-M
MOTORE - ENGINE

LUBRIFICAZIONE
LUBRICATION

1	49575	1	VITE TCEI 5X45 UNI 5931	BOLT TCEI 5X45
2	49570	1	VITE TCEI 5X50 UNI 5931	SCREW TCEI 5X50
3	49476	3	VITE TCEI 5X20 UNI 5931	BOLT TCEI 5X20
4	F30966	1	COPERCHIO POMPA H2O 250Fi 11/-	COVER, WATER PUMP 250Fi M.2011
5	F12327	1	O RING COPERCHIO P.ACQUA 250N	O-RING COVER WATER PUMP 250 4S
6	F49841	1	TAPPO COP. POMPA H2O 250Fi	CAP, COVER WATER PUMP 250 4S
7	F05833	1	GUARNIZ.COP.POMPA ACQUA.250N	GASKET, H2O COVER 250Fi
8	F28679	1	GIRANTE POMPA ACQUA 250N	IMPELLER, H2O PUMP 250Fi
9	04017	1	PARAOLIO CENTRIFUGA 06 +MF1TAG	OIL SEAL 8 X 22 X 7 TC
10	F49925	1	TAPPO CARICO OLIO M20X1.5	OIL PLUG M20X1,5
11	F49920	1	RONDELLA ALL 20.4X26X1.5	WASHER 20,4X26X1,5 ALUM.
12	F30961	1	COPERCHIO TRAS. PRIM. 250N '11	COVER, PRIMARY DRIVE 250N 11->
13	49119	1	RONDELLA 5 x 9 x 1,5 ALLUMINIO	WASHER, 5 x 9 x 1.5 ALLUMINIUM
14	49477	7	VITE TCEI 5X25 UNI 5931-912 Brun	BOLT TCEI 5X25
15	26041	2	GRANO CENTRAGGIO D.7X8 F.5,2	DOWEL PIN 7 x 8 Hole 5,2
16	F05828	1	GUARNIZ.COP.TRASM.PRIMAR.250N	GASKET, CLUTCH CASE 250Fi
17	F32529	1	DISCHETTO PARZIAL. MAND.OLIO 250N	DISC OIL PUMP 250 F.S.
18	F04390	1	PARAOLIO FAJ 14-22-5 HS	OIL SEAL FAJ 14-22-5 HS
19	F49913	1	SEEGER I 23	CIRCLIP INT. 23
20	49478	1	VITE TCEI 5X30 UNI 5931	BOLT TCEI 5X30
21	F12325	1	OR ORM 090-15 FILTRO ASP.OLIO 250N	O-RING
22	F32532	1	FILTRO ASPIRAZ.POMPE OLIO 250N	FILTER, OIL, 250Fi
23	F12343	1	O RING FILTRO OLIO 250F	O-RING
24	F32555	1	FILTRO ASPIRAZIONE OLIO MAGG.	FILTER OIL INLET
25	F28658	1	ALBERINO POMPA H2O 250N	SHAFT, WATER PUMP 250Fi
26	F40112	1	INGRANAGGIO COND.P.ACQUA Z 21 300 4T	
27	F03365	1	CUSCINETTO POMPA ACQUA 250/09	BEARING WATER PUMP 250/09
28	F04363	1	PARAOLIO 8X22X5 250/09->	OIL SEAL 8x22x5 (250F/09)



4T300FIMX23-M
MOTORE - ENGINE

LUBRIFICAZIONE
LUBRICATION

5

29	F66510	1	FILTRO OLIO 4Tempi HF 141	OIL FILTER HF - 141
30	12094	1	O RING COP. FILTRO OLIO	O RING OIL FILTER COVER
31	F12302	1	O RING 108 PIOGGIA CAMBIO 4T	O-RING, 108 GEAR F.S.
32	F30965	1	COPERCHIO FILTRO OLIO 250Fi 11	CAP, OIL FILTER 250Fi 11->
33	F30068	1	POMPA OLIO COMPLETA 250/300 Fi TWIN	OIL PUMP ASSY
34	F40997	1	INGRANAGGIO POMPA OLIO 250Fi Z 9	GEAR, OIL PUMP 250Fi 9 T
35	F19513	3	RULLINO ING. POMPA 250/09	PIN, PUMP GEAR 250 09->
36	F28840	1	ALBERINO POM.OLIO RO.H10/2XH10	SHAFT, OIL PUMP
37	49751	2	VITE TCEI 5X22	BOLT TCEI 5 X 22
38	F30059	1	CORPO POMPA	OIL PUMP BODY
39	F32533	1	PIST.NE VALV.LIMIT.PRESS.OLIO	PISTON
40	F16441	1	MOLLA VALVOLA PRESS.OLIO 250N	SPRING
41	49600	1	RONDELLA 4x8x0,8	WASHER 4
42	49267	1	SEEGER 8mm INT Sp. 0,8	SEEGER
43	F32577	3	ROTORE INTERNO POMPA OLIO 250Fi	ROTOR, OIL PUMP, INTERNAL
44	F32578	3	ROTORE ESTERNO POMPA OLIO 250Fi	ROTOR, OIL PUMP, EXTERNAL
45	F19521	2	RULLINO D.3 X 11	PIN 3 X 11
46	F32574	1	SEPARATORE POMPA OLIO	PLATE
47	49429	1	VITE TSEI 4X35	BOLT TSEI 4X35
48	F49821	1	SEEGER ING. FOLLE P.OLIO 250/09	SEEGER INTER.GEAR OIL P.250 4S
49	F19512	2	RALLA ING.FOLLE P. OLIO 250/09	THRUST WASHER
50	F40909	1	INGR. OZIOSO POMPA OLIO 250N	GEAR, OIL PUMP
51	F28665	1	ALBERINO ING.FOLLE P.OLIO 250N	SHAFT
52	F19511	1	GABBIA RULLI ING.F.P.OL.250/09	NEEDLE CAGE GEAR 250F 09->

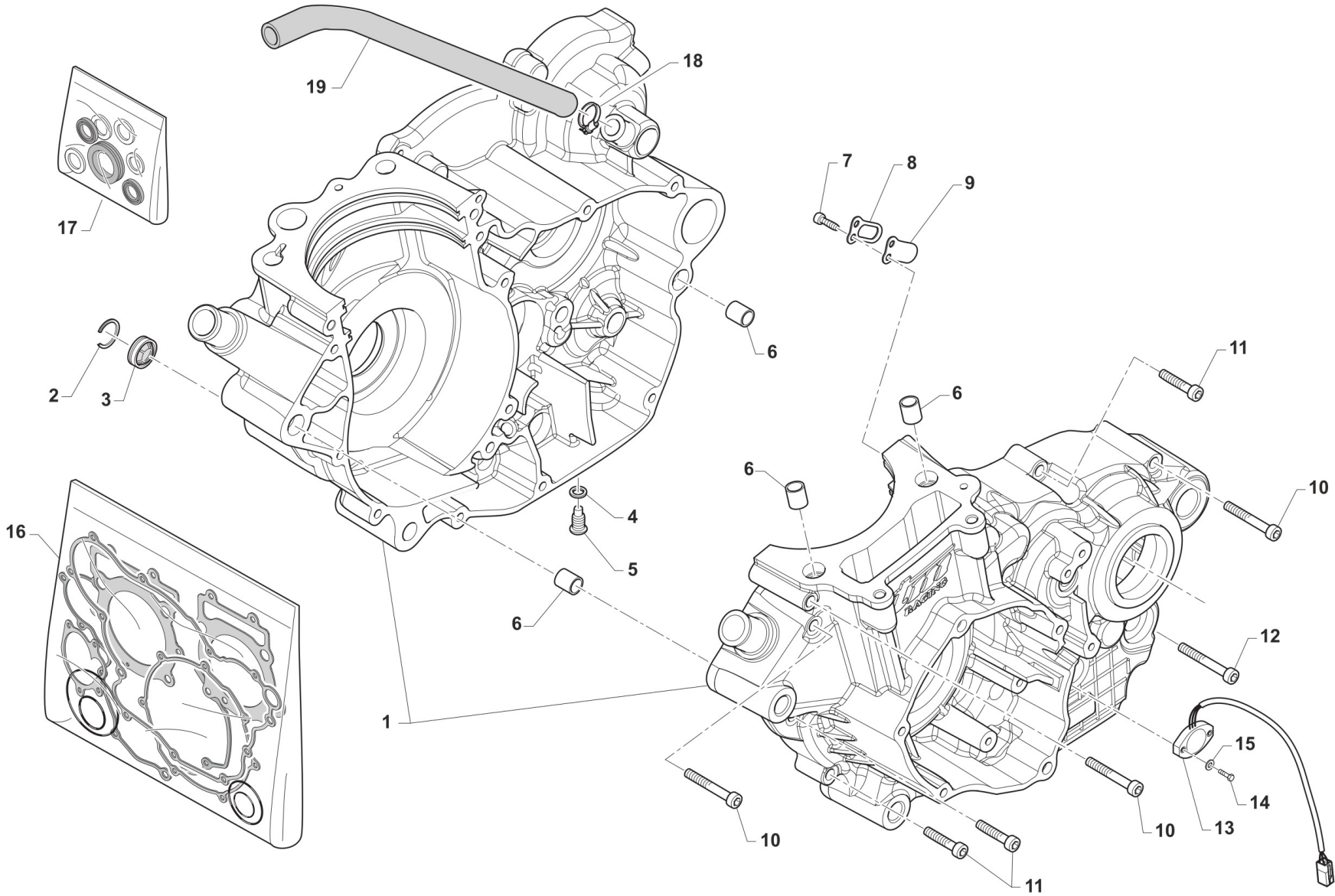

TM 0006.01



4T300FIMX23-M
MOTORE - ENGINE

CARTER MOTORE
CLUTCH CASE

1	F30076	1	BASAMENTO MOT. 300Fi ES TWIN 20	
2	F49832	1	SEEGER SB25 OBLO' 250Fi 10/->	SEEGER
3	F04366	1	OBLO' LIVELLO OLIO DIAM.25 MM	OIL LEVEL INSPECTION SIGHT GLASS
4	49125	2	RONDELLA 12X18X1,5 ALLUMINIO	WASHER 12X18X1,5 Al
5	F49820.1	2	TAPPO OLIO C/CALAM. 250Fi	OIL PLUG WITH MAGNET 250Fi
6	F26428	4	GRANO RIFERIMENTO 12X13 F10.2	GRUB SCREW 12X13 H.10,2mm
7	49542	1	VITE TCEI 5X10 UNI 5931	BOLT TCEI 5 X 10
8	F20004	1	STOPPER LAMELL.CAMERA ALB.250N	STOPPER, STOP
9	F20003	1	LAMELLA SFIATO PRESS.250Fi	REED
10	49491	3	VITE TCEI 6X55	BOLT TCEI 6X55
11	49487	4	VITE TCEI 6X35 UNI 5931	BOLT TCEI 6X35
12	49492	1	VITE TCEI 6X60	BOLT TCEI 6X60
13	F08456	1	SENSORE POSIZIONE CAMBIO eM060 CPL G.ORARIO (SOSTITUISCE F08236.1)	
14	49922	2	VITE TE 3X14	
15	49926	2	RONDELLA 3X9X1	WASHER 3 X 9 X 1
16	F05864	1	KIT GUARNIZIONI 300Fi EN/MX MY20 REPLICA	GASKETS 300FI EN7MX MY20->
17	04043	1	KIT PARAOLI 4T 250/300Fi TWIN MY2022	
18	51073	1	FASCETTA 10/19	CLAMP 10 / 19 mm
19	F65104	1	TUBO COPOLAN GRIGIO 11x16	HOSE COPOLAN GREY 11X16mm

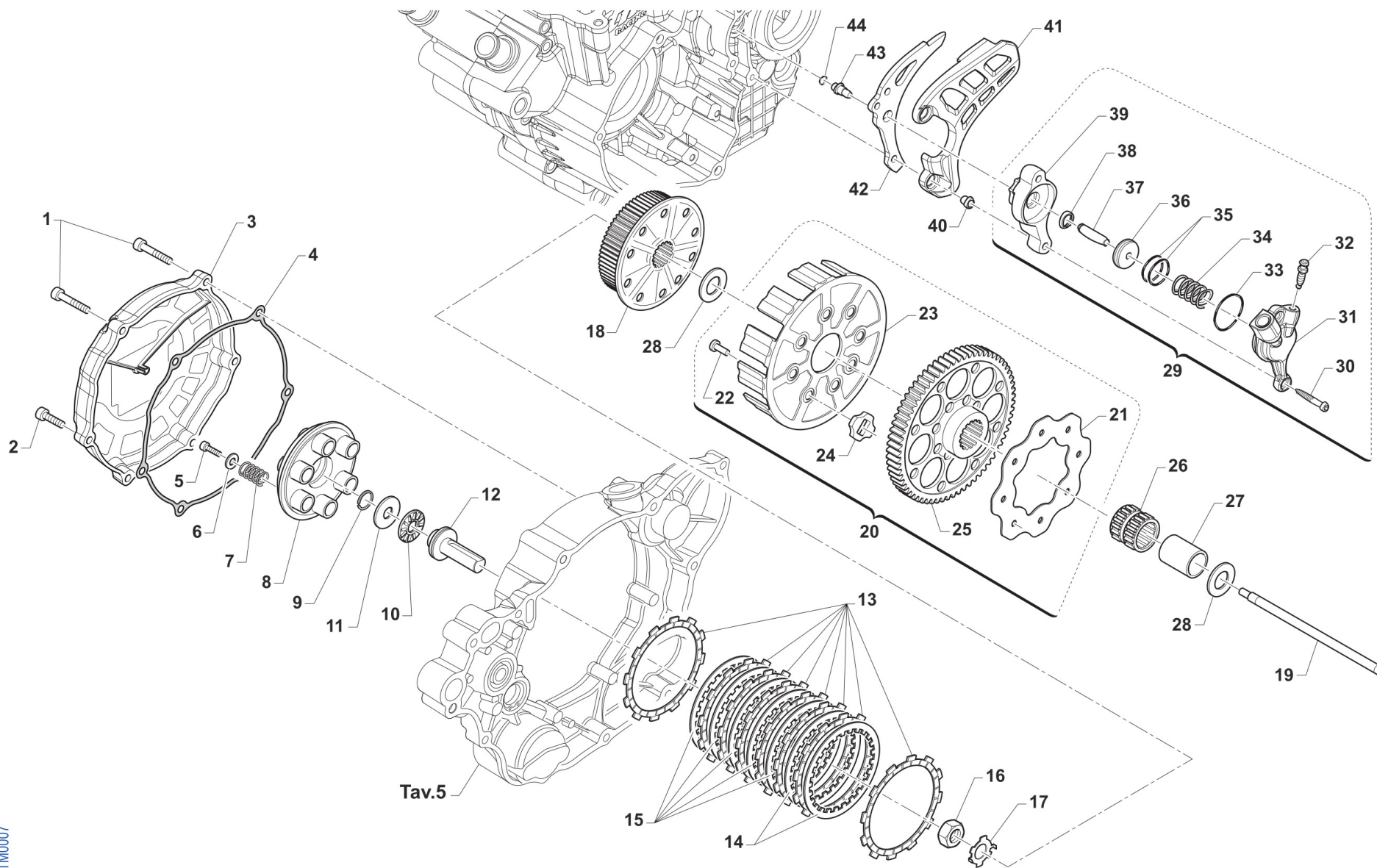



4T300FIMX23-M
MOTORE - ENGINE

FRIZIONE
CLUTCH

1	49736	2	VITE TCEI 5X65	BOLT TCEI 5X65
2	49477	4	VITE TCEI 5X25 UNI 5931-912 Brun	BOLT TCEI 5X25
3	F30960	1	COPERCHIETTO FRIZ.250Fi M.11->	COVER, CLUTCH 250Fi M. 11/->
4	F05841	1	GUARN. COP. FRIZ. 250Fi 2011	GASKET, CLUTCH COV 250Fi 11/->
5	49484	6	VITE TCEI 6X20	BOLT TCEI 6X20
6	49604	6	RONDELLA 6 X18 X 1,6	WASHER 6x18
7	F16453	6	MOLLA FRIZIONE 2/4T 250/450	SPRING, CLUTCH 2/4T 250/450
8	F25258	1	PIATTO SPINGIDISCHI 250Fi	PRESSURE PLATE, CLUTCH 250Fi
9	09006	1	ANELLINO FERMA SPINOTTO 80/85/100	CLIP, PISTON PIN 80/85/100cc
10	19022	1	GABBIA A RULLI RAD. AXK 1528	BUSH CAGE AXK 1528, RADIAL
11	19023	1	RONDELLA GABBIA RULLI AS 1528	WASHER, NEEDLE CAGE AS 1528
12	F35582	1	FUNGO FRIZIONE IDRAULICA 2015	PIECE, CLUTCH LIFTER
13	F35588	8	DISCO FRIZIONE 250Fi 4T FCC	CLUTCH PLATE, FIBER 250Fi 4S
14	F35596	2	DISCO FRIZ. ACC 1,8 mm 250Fi	CLUTCH DISC STEEL 1,8 mm 250Fi
15	F35541	5	DISCO FRIZ. ACC 1,5 mm 250N	CLUTCH PLATE, STEEL 1,5 250Fi
16	49060	1	DADO TAMBUR.FRIZ. ALB.PRIM. 250/300 M18X1.5	NUT, CLUTCH CENTER 250cc
17	35050	1	RONDELLA X FRIZ. 250/300/4T	CLUCTH WASHER 250/300/F
18	F25256	1	TAMBURELLO FRIZ.250F -N-	CLUTCH CENTER 250Fi
19	F35544	1	ASTINA CENTRAL.FRIZ.192mm 250N	ROD, CLUTCH 192mm 250N
20	F40159	1	COPPIA PRIMARIA CPL 300Fi Z 59/18	
21	35262	1	DISCO BATTUTA GOMMINI FRIZ. 2T/4T F.6 MM	PLATE, CLUTCH BASKET 250cc
22	49202	8	CHiodo FRIZIONE K3/KV/K7 D 5,8	PIN CLUTCH K3/KV/K7/K8/K9
23	F25257	1	CAMPANA FRIZ. 250Fi	CLUTCH BASKET 250Fi M. 10/->
24	21005	8	GOMMINO PARASTRAPPI FRIZIONE	RUBBER, CLUTCH BASKET
25	F40114	1	CORONA TRAS.PRIMARIA Z 59/18 300 4T	
26	F19510	1	GABBIA A RULLINI K 27X32X23.8	NEEDLE CAGE 27 x 32 x 23.8
27	F26422	1	BOCCOLA INGR.TRASM.PRIM. 250N	BUSH, PRIMARY GEAR 250Fi
28	48250	2	SPESSORE COPPIA PRIMARIA 250	SPACER, PRIMARY GEAR 250cc



4T300FIMX23-M
MOTORE - ENGINE

FRIZIONE
CLUTCH

29	F30005	1	COP. FRIZ/IDR 4T 250N D.26 CPL	COVER, IDR/CLUTCH 4S 250N ASSY
30	49535	2	VITE TCEI 5X35 UNI 5931-912 Brun	BOLT TCEI 5X35
31	F30006	1	CORPO CILIN. FRIZ. 250Fi D.26	BODY CLUTCH CYLINDER 250Fi D26
32	35264	1	VITE SPURGO OLIO FRIZ.IDR.6X1	SCREW AIR BLED HYDRAUL.CLUTCH
33	12252	1	O RING PIGNONE CAT.+DIS.AL.MOT	O-RING, 25,12 x 1,78
34	F16445	1	MOLLA PIST. FRIZ. 250N	SPRING
35	12259	2	O RING PISTONE FR.125/250VERDE	O-RING, CLUTCH PISTON 125/250
36	F35522	1	PISTONE CILINDRETTO 250N D.26	PISTON CLUTCH CYLINDER 250F 26
37	F19518	1	RULLO D.S. 5 X 24	PIN 5 X 24
38	F04367	1	PARAOLIO 9X13X3	OIL SEAL 9X13X3
39	F35523	1	DISTANZIALE CILINDRETTO 250N	SPACER CYLINDER 250N
40	26211	2	BOCCOLA PROT. PIGNONE 250 F.5	COLLAR, SPROCKET 250cc H.5
41	F30944	1	PROTEZIONE PIGNONE 250Fi PLAST	SPROCKET PROTECTION 250 F.I. PLAST.
42	F70370	1	PROTEZ. ERGAL PIGN. CAT 250N	PROTECTION, ALUMINIUM, FRONT SPROCKET
43	F26460	1	DIST.CENTR.SUPP.ATT.FRIZ.250N	SPACER
44	F12302	1	O RING 108 PIOGGIA CAMBIO 4T	O-RING, 108 GEAR F.S.

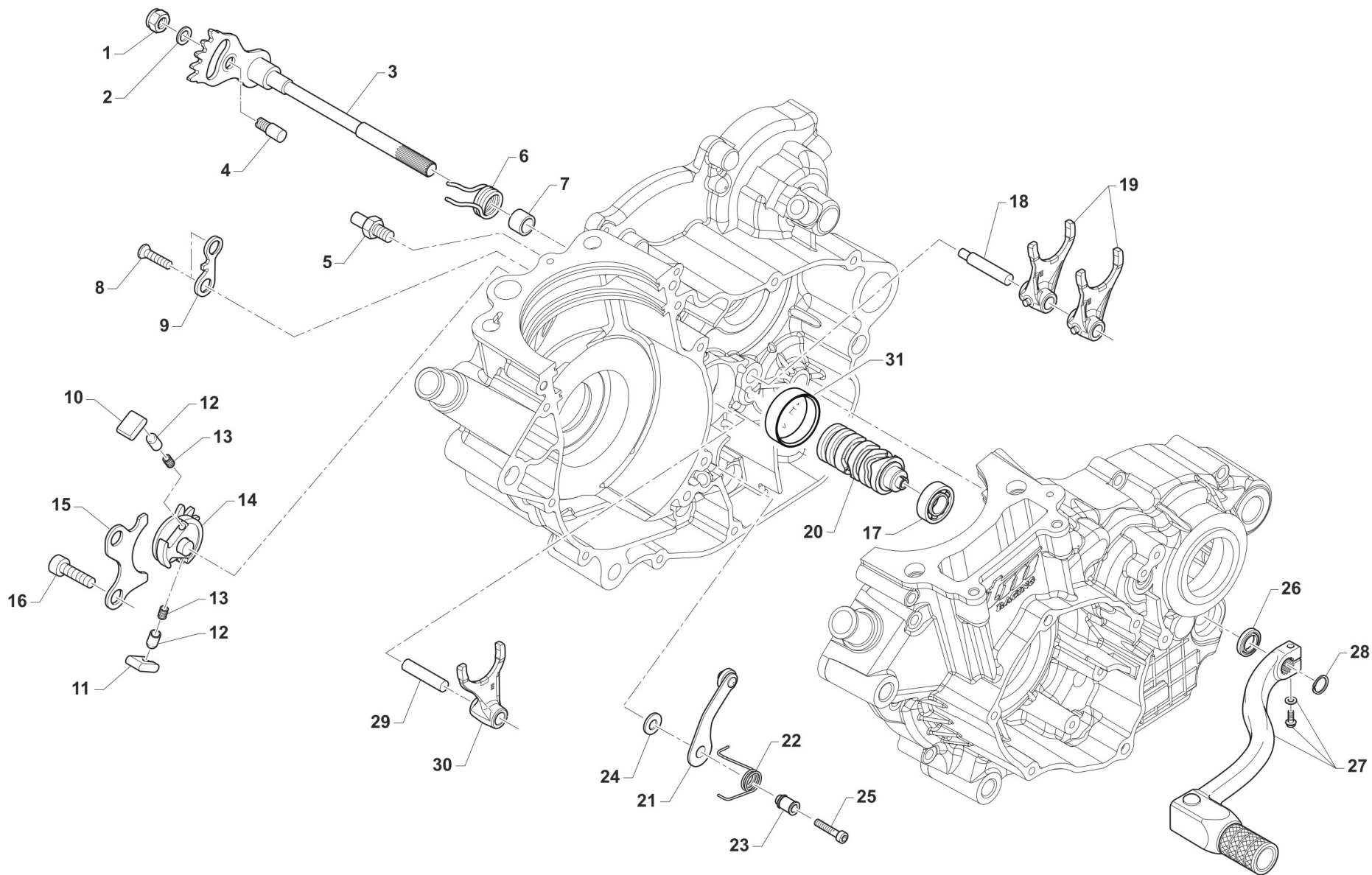

TM0008



4T300FIMX23-M
MOTORE - ENGINE

COMANDO CAMBIO
GEARSHIFT MECHANISM

1	49638	1	DADO M 6 ALTO AUTOBLOCCANTE	NUT 6mm, HIGHT SELF-LOCKING
2	49603	1	RONDELLA M 6,4 X 12 X 1,6	WASHER 6x12
3	28100	1	ALBERO COMANDO ING. P.TACRIC.	SHAFT, GEARSHIFT
4	26050	1	BATTUTA ECCENTRICA	ADJUSTER SELECTOR SHAFT
5	F26455	1	BATTUTA FISSA MAN.CAMBIO 250N	
6	16010	1	MOLLA RITORNO LEVA CAMBIO 3	SPRING, RETURN GEAR LEVER 3mm
7	26006	1	DISTANZIALE MOLLA LEVA CAMBIO	SPACER, GEAR LEVER SPRING
8	49405	2	VITE TSEI 6X20 UMB.5933 10.9	BOLT TSEI 6x20 U.5933 10.9
9	F26454	1	PIASTR.FINECORSA CRIC. 250N	PLATE, ENDSTROKE RATCHET 250N
10	26060	1	CRICCHETTO CAMBIO SUPERIORE	RATCHET UP, GEAR
11	26061	1	CRICCHETTO CAMBIO INFERIORE	RATCHET DOWN, GEAR
12	26062	2	PUNTALE PER CRICCHETTO CAMBIO	PIN, RATCHET GEAR
13	16012	2	MOLLA PER PUNTALE	SPRING, GEARBOX PIN
14	40310	1	INGRANAGGIO PORTACRICCHETTI	DRUM SHIFTER GEAR
15	26021	1	PIASTRINO RIENTRO CRICCHETTI	PLATE, RATCHET
16	49483	2	VITE TCEI 6X16 UNI 5931	BOLT TCEI 6X16
17	03012	1	CUSCINETTO DESMODROMICO 6001 2RS	BUSH, 6001 2RS GEAR DRUM
18	33256	1	PERNO FORCH.ALB.SEC. 250 / 125.99	AXEL, COUNTERSHAFT FORK 250cc
19	F33312.1	2	FORCHETTA A/S 300Fi CROMATA	FORK SHIFT COUNTERS.300FiCHROM
20	F33353.1	1	DESMODROMICO 250-300 4T 6M. PR.4	
21	26095	1	PIASTRINO BLOCCAMARCE KV/95CPL + MOTO	PLATE, STOP GEAR KV/95 ASSY
22	F16447.3	1	MOLLA BLOCCA MARCE 250 4T D.FILO 2.4	
23	26007	1	DISTANZIALE MOLLA BLOCCAMARCE	SPACER, STOP GEAR SPRING
24	49604	1	RONDELLA 6 X18 X 1,6	WASHER 6x18
25	49485	1	VITE TCEI 6X25 UNI 5931	BOLT TCEI 6x25
26	04004	1	PARAOLIO POMPA H2O-LEVA CAMBIO	OIL SEAL 12 x 22 x 5
27	43049	1	LEVA CAMBIO 2T (485) MY19->	GEAR LEVER 250 / 300 T.STR. EL.ST. M.19->
28	49212	1	SEEGER E12 LEVA CAMBIO	CIRCLIP D.12 - EXTERNAL



4T300FIMX23-M
MOTORE - ENGINE

COMANDO CAMBIO
GEARSHIFT MECHANISM

29	33255	1	PERNO FORCH.ALB. PRIM.250 / 125.99	AXEL, MAINSHAFT FORK 250cc
30	F33311.1	1	FORCHETTA A/P 300Fi CROMATA	SHIFT FORK MAINSH.300Fi CHROME
31	19041	1	ASTUCCIO A RULLI DHK 35/12	BUSH NEEDLE CAGE DHK 35/12

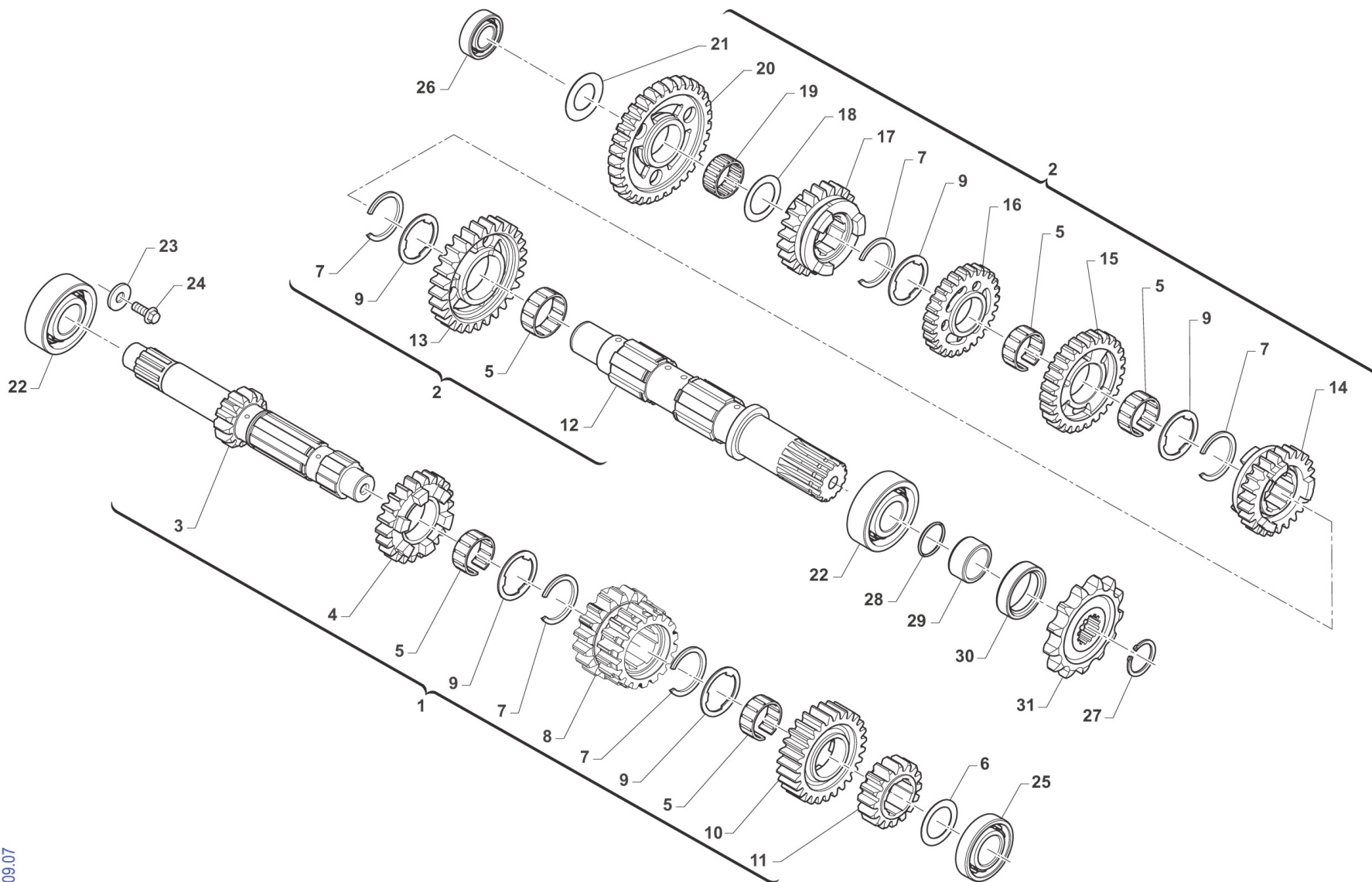

TM0009.07



4T300FIMX23-M
MOTORE - ENGINE

CAMBIO
GEAR BOX

1	F40240	1	ALBERO PRIMARIO 300Fi MX 23 4T (6 ALETTE) CPL	
2	F40241	1	ALBERO SECONDARIO 300Fi MX 23 4T (6 ALETTE) CPL	
3	F40215	1	ALBERO PRIMARIO Z 13 6 ALETTE 300 4T	
4	F40218	1	INGRANAGGIO 5a A.P. Z20 6 ALETTE 300 4T	
5	F19524	5	GABBIA A RULLI 22X26X10 TAGL.	NEEDLE BEARING 22 X 26 X 10
6	48253	1	SPESSORE CAMBIO 17X30X1 250	SPACER, GEAR BOX 250cc 17X30X1
7	F49869	5	SEEGER SW 24 (EST.) "SEEGER"	CIRCLIP SW 24 (EXTERNAL)
8	F40217	1	INGRANAGGIO 3/4a A.P.Z16/20 6 ALETTE 300 4T	
9	48258	5	SPESSORE DENT.CAMBIO INT.55 6M	SPACER GEAR INT.55 6S
10	F40219	1	INGRANAGGIO 6a A.P. Z22 6 ALETTE 300 4T	
11	F40216	1	INGRANAGGIO 2a A.P. Z15 6 ALETTE 300 4T	
12	F40220	1	ALBERO SECONDARIO 6 ALETTE 250/300 4T	
13	F40222	1	INGRANAGGIO 2a A.S. Z27 6 ALETTE 300 4T	
14	F40226	1	INGRANAGGIO 6a A.S. Z20 6 ALETTE 300 4T	
15	F40223	1	INGRANAGGIO 3a A.S. Z24 6 ALETTE 300 4T	
16	F40224	1	INGRANAGGIO 4a A.S. Z23 6 ALETTE 300 4T	
17	F40225	1	INGRANAGGIO 5a A.S. Z21 6 ALETTE 300 4T	
18	F48353	1	SPESSORE PS 18X25X1	SPACER
19	F19514	1	GABBIA A RULLI 18X22X10	NEEDLE CAGE 18X22X10
20	F40221	1	INGRANAGGIO 1a A.S. Z31 6 ALETTE 300 4T	
21	48012	1	RASAMENTO A/S M/M SPESS.0,5	SPACER, 26x17x0,5
22	F03368	2	CUSCINETTO 62/22 C3 22x50x14	BUSH, 62/22 C3 22x50x14
25	03254	1	CUSCINETTO A.P.4 Tempi 2RS1/C3	BUSH, MAINSHAFT 2RS/C3 4S
27	49217	1	SEEGER E22 ANELLO ALB/S	CIRCLIP D.22 - COUNTERSHAFT
27	F03367	1	CUSCINETTO 6003 TN9C3 17x35x10	BUSH, 6003 TN9 C3 17x35x10
28	F12320	1	O RING BOCCOLA PIGNONE 250/09	O-RING NBR 2087
29	F26421	1	DISTANZ. PIGNONE CATENA 250N	SPACER SPROCKET CHAIN 250N
30	04113	1	PARAOLIO 28X38X7 125TAG	OIL SEAL 28 x 38 x 7



4T300FIMX23-M
MOTORE - ENGINE

CAMBIO
GEAR BOX

31	F40889	1	PIGNONE CATENA 250N - Z13	SPROCKET 13T, DRIVE 250Fi
31	F40933	1	PIGNONE CATENA 250N - Z14	SPROCKET 14T, DRIVE 250Fi
31	F40956	1	PIGNONE CATENA 250N - Z12	SPROCKET 12T, DRIVE 250Fi

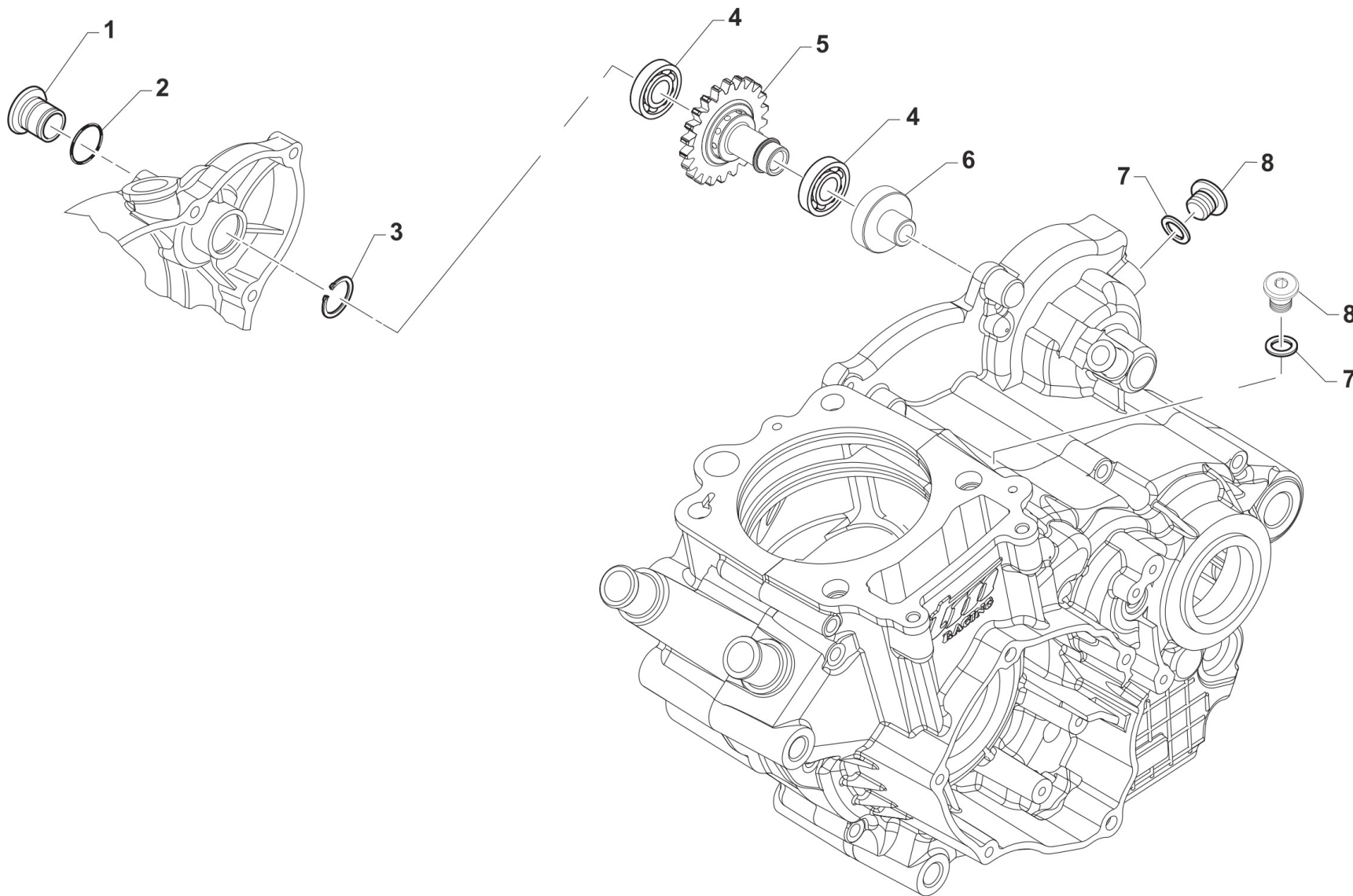



4T300FIMX23-M
MOTORE - ENGINE

CENTRIFUGATORE AVVIAMENTO

10

1	26234	1	TAPPO FORO ALBERINO M/M 250/300 4T	
2	12092	1	O RING REGISTRO ALTE VELOCITA'	
3	F49914	1	SEEGER E 18	CIRCLIP E D.18
4	03149	2	CUSCINETTO 61902-2RS1/C3	
5	40223	1	INGR. CENTRIFUGATORE Z24 300 4T	
6	F26518	1	SUPPORTO CUSCINETTO 61902	
7	F49939	2	RONDELLA RAME 8 X13 X 1,5	WASHER COPPER 8,5X13X1,5
8	F49823	2	TAPPO ALBERINO ROT.BILANC.250N e CARTER	PLUG, SHAFT 250N

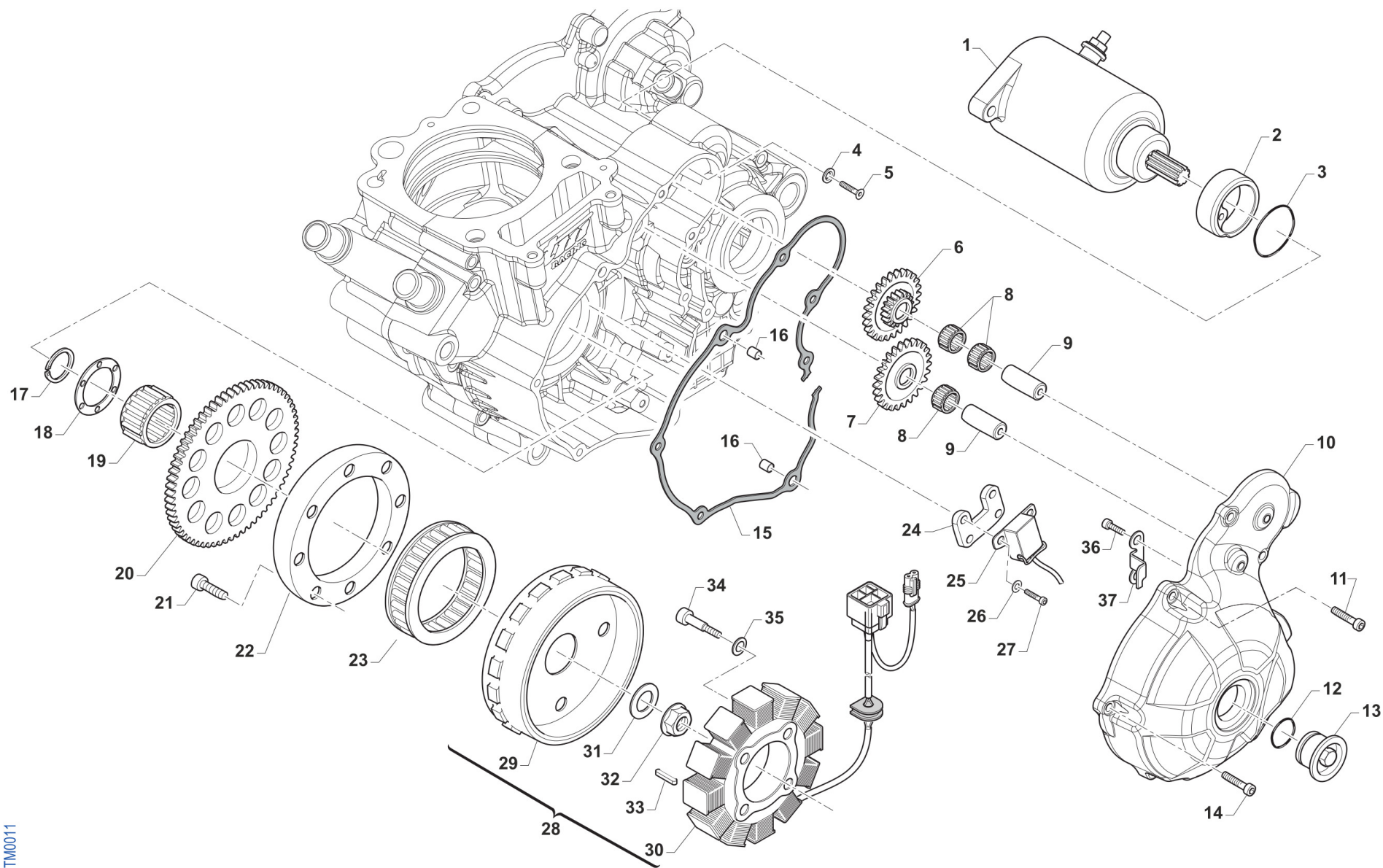

TM0011



4T300FIMX23-M
MOTORE - ENGINE

ACCENSIONE ES
IGNITION ES

1	F68145	1	MOTORINO AVVIAMENTO 250N M08 SM 14 A8323-048-00-000	E-STARTER ENGINE 250 4 S 08->
2	F26341	1	BOCCOLA CENTRAGGIO MOT.AVVIAM.	COLLAR, EL. STARTER
3	F12309	1	O RING 2150	O-RING, 2150
4	F49818	1	ROSETTA SPECIALE D.6 SVASATA	WASHER SPECIAL D.6
5	49399	1	VITE TSEI 5X12	BOLT TSEI 5x12
6	F40839	1	INGRANAGGIO DOPPIO RINF. E.S.	GEAR, ELECT. START
7	F40808	1	INGR. FOLLE AVVIAMENTO EL.	INTERMEDIATE GEAR
8	F19501	3	GABBIA A RULLI 10X13X10 4T	NEEDLE CAGE 10X13X10 F.S.
9	F28568	2	ALBERINO LUNGO ING. AVV.ELETTR	SHAFT, EL. STARTER GEAR
10	F30963	1	COP. ACC. 250Fi MX/ES 10/-> ATTACCO ACCENSIONE 4 FORI	COVER IGNITION 250Fi MX/ES10->
11	49477	2	VITE TCEI 5X25 UNI 5931-912 Brun	BOLT TCEI 5X25
12	F12322	1	O RING 2106	O-RING
13	F49833	1	TAPPO COPERCHIO ACC.250Fi	COVER CAP ALUMINIUM 250Fi
14	49476	5	VITE TCEI 5X20 UNI 5931	BOLT TCEI 5X20
15	F05829	1	GUARNIZ.COP.ACCENSIONE ES 250N	GASKET, INGNIT.COVER ES 250Fi
16	26041	2	GRANO CENTRAGGIO D.7X8 F.5,2	DOWEL PIN 7 x 8 Hole 5,2
17	F49937	1	SEEGER ALBERO E 36 4T	CIRCLIP 36 CRANKSH. E 4S
18	F26327	1	RONDELLA ACC. 37X53X2 4T	WASHER 37X50X2 4S.
19	F19506	1	GABBIA A RULLI AVV.EL.37X42X17	NEEDLE CAGE 37X42X17 E.S.
20	F40807	1	INGR. CONDOTTO AVVIAMENTO EL.	GEAR EL. STARTER
21	F49929	8	VITE TCE BASSA 6X16 (CL. 12.9)	SCREW TCE 6 X 16
22	F26385	1	ANELLO ESTERNO PESANTE R.L.KOK	EXTERNAL RING IGNITION KOKUSAN
23	F03354	1	RUOTA LIBERA MOTORINO AVV. 4T	FREE-WHEEL ELECTRIC STARTER
24	F08075	1	PIASTRINO PICK-UP 250Fi MX/ES	
25	F15478	1	PICK-UP KOKUSAN	PICK-UP KOK PU5157
26	49601	2	RONDELLA 5X11	WASHER 5x11
27	49452	2	VITE TE 8X30	



4T300FIMX23-M
MOTORE - ENGINE

ACCENSIONE ES
IGNITION ES

11

28	F15561	1	GENERATORE KOKUSAN MX E.S. KOK / SUMIT. 2V	GENERATOR KOKUSAN MX E.S.
29	F15549	1	ROTORE KOKUSAN YF9019	ROTOR, KOKUSAN YF9019
30	F15547	1	STATORE KOKUSAN YS 9018 C. KOK / SUM	
31	49613	1	RONDELLA ACCIAIO 12	STEEL WASHER 12
32	49056	1	DADO ACCENS 100/TAG/KZ 125MX/E	NUT, IGNITION 100cc
33	F49853	1	CHIAVETTA 5X3X25 UNI7510R.F.A.	WOODRUFF KEY, 5x3x25
34	49384	4	VITE TCEI 4X35	
35	49866	4	RONDELLA 4 x 12 x 1	
36	49553	2	VITE TCEI 4X8 5931-912 Brun	BOLT TCEI 4X8
37	F30945	1	PROTEZIONE CAVI ACC.NE 250N	PROTECTION IGNITION WIRES 250N



4T300FIMX23-M MOTORE - ENGINE

-

03012	4T300FIAA23-M-08	17	1
03026	4T300FIMX22-M-03	8	2
03149	4T300FI23-M-10	4	2
03254	4T300FIMX23-M-09	25	1
04004	4T300FIAA23-M-08	26	1
04017	4T300FIMX20-M-05	9	1
04043	4T300FIAA22-M-06	17	1
04113	4T300FIMX23-M-09	30	1
09006	4T300FIMX20-M-07	9	1
12092	4T300FI23-M-10	2	1
12094	4T300FIMX20-M-05	30	1
12252	4T300FIMX20-M-07	33	1
12259	4T300FIMX20-M-07	35	2
16010	4T300FIAA23-M-08	6	1
16012	4T300FIAA23-M-08	13	2
19022	4T300FIMX20-M-07	10	1
19023	4T300FIMX20-M-07	11	1
19041	4T300FIAA23-M-08	31	1
21005	4T300FIMX20-M-07	24	8
26006	4T300FIAA23-M-08	7	1
26007	4T300FIAA23-M-08	23	1

26021	4T300FIAA23-M-08	15	1
26041	4T300FIMX20-M-05	15	2
	4T300FIMX20-M-11	16	2
26050	4T300FIAA23-M-08	4	1
26060	4T300FIAA23-M-08	10	1
26061	4T300FIAA23-M-08	11	1
26062	4T300FIAA23-M-08	12	2
26095	4T300FIAA23-M-08	21	1
26211	4T300FIMX20-M-07	40	2
26234	4T300FI23-M-10	1	1
28100	4T300FIAA23-M-08	3	1
33255	4T300FIAA23-M-08	29	1
33256	4T300FIAA23-M-08	18	1
35050	4T300FIMX20-M-07	17	1
35262	4T300FIMX20-M-07	21	1
35264	4T300FIMX20-M-07	32	1
40223	4T300FI23-M-10	5	1
40310	4T300FIAA23-M-08	14	1
43049	4T300FIAA23-M-08	27	1
48012	4T300FIMX23-M-09	21	1
48250	4T300FIMX20-M-07	28	2
48253	4T300FIMX23-M-09	6	1

48258	4T300FIMX23-M-09	9	5
49056	4T300FIMX20-M-11	32	1
49060	4T300FIMX20-M-07	16	1
49119	4T300FIMX20-M-05	13	1
49125	4T300FIAA22-M-06	4	2
49202	4T300FIMX20-M-07	22	8
49212	4T300FIAA23-M-08	28	1
49217	4T300FIMX23-M-09	27	1
49255	4T300FIMX22-M-03	13	1
49267	4T300FIMX20-M-05	42	1
49384	4T300FIMX20-M-11	34	4
49396	4T300FIMX23-M-02	30	1
49399	4T300FIMX20-M-11	5	1
49405	4T300FIAA23-M-08	8	2
49406	4T300FIMX22-M-04	26	2
49429	4T300FIMX20-M-05	47	1
49452	4T300FIMX20-M-11	27	2
49472	4T300FIMX22-M-03	11	1



4T300FIMX23-M MOTORE - ENGINE

49476	4T300FIMX20-M-05	3	3
	4T300FIMX20-M-11	14	5
49477	4T300FIMX20-M-05	14	7
	4T300FIMX20-M-07	2	4
	4T300FIMX20-M-11	11	2
49478	4T300FIMX20-M-05	20	1
49481	4T300FIMX23-M-02	33	3
49482	4T300FIMX22-M-04	32	4
49483	4T300FIAA23-M-08	16	2
49484	4T300FIMX20-M-07	5	6
49485	4T300FIAA23-M-08	25	1
49487	4T300FIAA22-M-06	11	4
	4T300FIMX23-M-02	3	8
49491	4T300FIAA22-M-06	10	3
49492	4T300FIAA22-M-06	12	1
49535	4T300FIMX20-M-07	30	2
49542	4T300FIAA22-M-06	7	1
49553	4T300FIMX20-M-11	36	2
	4T300FIMX23-M-02	27	2

49570	4T300FIMX20-M-05	2	1
49575	4T300FIMX20-M-05	1	1
49597	4T300FIMX22-M-04	13	1
49600	4T300FIMX20-M-05	41	1
49601	4T300FIMX20-M-11	26	2
49603	4T300FIAA23-M-08	2	1
49604	4T300FIAA23-M-08	24	1
	4T300FIMX20-M-07	6	6
49613	4T300FIMX20-M-11	31	1
49638	4T300FIAA23-M-08	1	1
49676	4T300FIMX20-M-01	12	2
49702	4T300FIMX23-M-02	5	1
49736	4T300FIMX20-M-07	1	2
49751	4T300FIMX20-M-05	37	2
49866	4T300FIMX20-M-11	35	4
49922	4T300FIAA22-M-06	14	2
49926	4T300FIAA22-M-06	15	2
49949	4T300FIMX22-M-04	29	1
49989	4T300FIMX23-M-02	39	3

51073	4T300FIAA22-M-06	18	1
F01729	4T300FIMX20-M-01	7	1
F02886	4T300FIMX23-M-02	1	1
F02887	4T300FIMX23-M-02	2	1
F03354	4T300FIMX20-M-11	23	1
F03365	4T300FIMX20-M-05	27	1
F03367	4T300FIMX23-M-09	27	1
F03368	4T300FIMX23-M-09	22	2
F03375.4	4T300FIMX22-M-03	4	1
F03375.5	4T300FIMX22-M-03	4	1
F04363	4T300FIMX20-M-05	28	1
F04366	4T300FIAA22-M-06	3	1
F04367	4T300FIMX20-M-07	38	1
F04375	4T300FIMX22-M-03	9	1
F04388	4T300FIMX23-M-02	11	4
F04390	4T300FIMX20-M-05	18	1
F05828	4T300FIMX20-M-05	16	1
F05829	4T300FIMX20-M-11	15	1



4T300FIMX23-M MOTORE - ENGINE

-

F05833	4T300FIMX20-M-05	7	1
F05841	4T300FIMX20-M-07	4	1
F05856.1	4T300FIMX20-M-01	8	1
F05856.2	4T300FIMX20-M-01	8	1
F05856.3	4T300FIMX20-M-01	8	1
F05856.4	4T300FIMX20-M-01	8	1
F05859.1	4T300FIMX20-M-01	5	1
F05864	4T300FIAA22-M-06	16	1
F06116	4T300FIMX23-M-02	37	1
F08003	4T300FIMX23-M-02	40	1
F08075	4T300FIMX20-M-11	24	1
F08456	4T300FIAA22-M-06	13	1
F09385	4T300FIMX20-M-01	4	2
F09396.2	4T300FIMX20-M-01	3	1
F10868.95	4T300FIMX20-M-01	1	1
F10868.96	4T300FIMX20-M-01	1	1
F10868.97	4T300FIMX20-M-01	1	1
F10868.98	4T300FIMX20-M-01	1	1

F11409	4T300FIMX20-M-01	2	1
F12302	4T300FIMX20-M-05	31	1
	4T300FIMX20-M-07	44	1
F12309	4T300FIMX20-M-11	3	1
F12320	4T300FIMX23-M-09	28	1
F12322	4T300FIMX20-M-11	12	1
F12325	4T300FIMX20-M-05	21	1
	4T300FIMX23-M-02	19	2
F12327	4T300FIMX20-M-05	5	1
F12343	4T300FIMX20-M-05	23	1
F12344.1	4T300FIMX22-M-04	3	1
F12345.1	4T300FIMX23-M-02	4	1
F12346.1	4T300FIMX22-M-04	27	1
	4T300FIMX23-M-02	25	1
F12351.1	4T300FIMX23-M-02	31	1
F12356.1	4T300FIMX22-M-04	31	1
F12357.1	4T300FIMX20-M-01	11	2

F12364	4T300FIMX22-M-04	2	1
F13287	4T300FIMX23-M-02	38	1
F14158	4T300FIMX23-M-02	14	2
F14164	4T300FIMX23-M-02	15	2
F14178	4T300FIMX23-M-02	7	8
F15478	4T300FIMX20-M-11	25	1
F15547	4T300FIMX20-M-11	30	1
F15549	4T300FIMX20-M-11	29	1
F15561	4T300FIMX20-M-11	28	1
F16441	4T300FIMX20-M-05	40	1
F16445	4T300FIMX20-M-07	34	1
F16447.3	4T300FIAA23-M-08	22	1
F16453	4T300FIMX20-M-07	7	6
F16472	4T300FIMX23-M-02	10	2
F16473	4T300FIMX23-M-02	9	2
F16479	4T300FIMX22-M-04	15	1
F18059	4T300FIMX22-M-03	5	1



4T300FIMX23-M MOTORE - ENGINE

-

F18104	4T300FIMX22-M-03	6	1
F18123	4T300FIMX22-M-03	3	1
F18125	4T300FIMX22-M-03	1	1
F18127	4T300FIMX22-M-03	2	1
F19501	4T300FIMX20-M-11	8	3
F19506	4T300FIMX20-M-11	19	1
F19510	4T300FIMX20-M-07	26	1
F19511	4T300FIMX20-M-05	52	1
F19512	4T300FIMX20-M-05	49	2
F19513	4T300FIMX20-M-05	35	3
F19514	4T300FIMX23-M-09	19	1
F19518	4T300FIMX20-M-07	37	1
F19521	4T300FIMX20-M-05	45	2
F19524	4T300FIMX23-M-09	5	5
F19526	4T300FIMX22-M-04	21	1
F19529	4T300FIMX22-M-04	4	4
F19530	4T300FIMX22-M-04	11	1

F20003	4T300FIAA22-M-06	9	1
F20004	4T300FIAA22-M-06	8	1
F21436	4T300FIMX23-M-02	36	1
F25256	4T300FIMX20-M-07	18	1
F25257	4T300FIMX20-M-07	23	1
F25258	4T300FIMX20-M-07	8	1
F26327	4T300FIMX20-M-11	18	1
F26341	4T300FIMX20-M-11	2	1
F26385	4T300FIMX20-M-11	22	1
F26421	4T300FIMX23-M-09	29	1
F26422	4T300FIMX20-M-07	27	1
F26428	4T300FIAA22-M-06	6	4
	4T300FIMX20-M-01	6	2
F26454	4T300FIAA23-M-08	9	1
F26455	4T300FIAA23-M-08	5	1
F26460	4T300FIMX20-M-07	43	1
F26518	4T300FI23-M-10	6	1
F26557	4T300FIMX23-M-02	16	2
F26558	4T300FIMX23-M-02	17	2

F26575	4T300FIMX22-M-04	12	1
F26576	4T300FIMX22-M-04	16	1
F26597	4T300FIMX23-M-02	8	4
F26603.255	4T300FIMX23-M-02	6	1
F26603.260	4T300FIMX23-M-02	6	1
F26603.265	4T300FIMX23-M-02	6	1
F26603.270	4T300FIMX23-M-02	6	1
F26603.275	4T300FIMX23-M-02	6	1
F26603.280	4T300FIMX23-M-02	6	1
F26603.285	4T300FIMX23-M-02	6	1
F26603.290	4T300FIMX23-M-02	6	1
F26603.295	4T300FIMX23-M-02	6	1
F26603.300	4T300FIMX23-M-02	6	1
F26603.305	4T300FIMX23-M-02	6	1
F26603.310	4T300FIMX23-M-02	6	1
F26603.315	4T300FIMX23-M-02	6	1
F26603.320	4T300FIMX23-M-02	6	1



4T300FIMX23-M MOTORE - ENGINE

-

F26689	4T300FIMX23-M-02	12	4
F26728.1	4T300FIMX23-M-02	13	4
F28568	4T300FIMX20-M-11	9	2
F28658	4T300FIMX20-M-05	25	1
F28665	4T300FIMX20-M-05	51	1
F28679	4T300FIMX20-M-05	8	1
F28807	4T300FIMX22-M-04	9	1
F28809	4T300FIMX22-M-04	10	1
F28810	4T300FIMX23-M-02	28	1
F28811	4T300FIMX23-M-02	21	1
F28812	4T300FIMX23-M-02	20	1
F28813	4T300FIMX22-M-04	22	1
F28835	4T300FIMX23-M-02	23	3
F28836	4T300FIMX23-M-02	22	1
F28840	4T300FIMX20-M-05	36	1
F28841	4T300FIMX23-M-02	24	1
F28846	4T300FIMX22-M-04	7	1

F28852	4T300FIMX22-M-04	6	1
F30005	4T300FIMX20-M-07	29	1
F30006	4T300FIMX20-M-07	31	1
F30015	4T300FIMX23-M-02	32	1
F30059	4T300FIMX20-M-05	38	1
F30060	4T300FIMX22-M-04	5	2
F30061	4T300FIMX22-M-04	1	8
F30068	4T300FIMX20-M-05	33	1
F30076	4T300FIAA22-M-06	1	1
F30944	4T300FIMX20-M-07	41	1
F30945	4T300FIMX20-M-11	37	1
F30960	4T300FIMX20-M-07	3	1
F30961	4T300FIMX20-M-05	12	1
F30963	4T300FIMX20-M-11	10	1
F30965	4T300FIMX20-M-05	32	1
F30966	4T300FIMX20-M-05	4	1
F32529	4T300FIMX20-M-05	17	1

F32532	4T300FIMX20-M-05	22	1
F32533	4T300FIMX20-M-05	39	1
F32555	4T300FIMX20-M-05	24	1
F32573	4T300FIMX22-M-03	10	1
F32574	4T300FIMX20-M-05	46	1
F32577	4T300FIMX20-M-05	43	3
F32578	4T300FIMX20-M-05	44	3
F33311.1	4T300FIAA23-M-08	30	1
F33312.1	4T300FIAA23-M-08	19	2
F33353.1	4T300FIAA23-M-08	20	1
F35522	4T300FIMX20-M-07	36	1
F35523	4T300FIMX20-M-07	39	1
F35541	4T300FIMX20-M-07	15	5
F35544	4T300FIMX20-M-07	19	1
F35582	4T300FIMX20-M-07	12	1
F35588	4T300FIMX20-M-07	13	8
F35596	4T300FIMX20-M-07	14	2
F40061	4T300FIMX22-M-04	20	1



4T300FIMX23-M MOTORE - ENGINE

-

F40062	4T300FIMX22-M-04	8	2
F40112	4T300FIMX20-M-05	26	1
F40114	4T300FIMX20-M-07	25	1
F40158	4T300FIMX22-M-03	12	1
F40159	4T300FIMX20-M-07	20	1
F40215	4T300FIMX23-M-09	3	1
F40216	4T300FIMX23-M-09	11	1
F40217	4T300FIMX23-M-09	8	1
F40218	4T300FIMX23-M-09	4	1
F40219	4T300FIMX23-M-09	10	1
F40220	4T300FIMX23-M-09	12	1
F40221	4T300FIMX23-M-09	20	1
F40222	4T300FIMX23-M-09	13	1
F40223	4T300FIMX23-M-09	15	1
F40224	4T300FIMX23-M-09	16	1
F40225	4T300FIMX23-M-09	17	1
F40226	4T300FIMX23-M-09	14	1

F40240	4T300FIMX23-M-09	1	1
F40241	4T300FIMX23-M-09	2	1
F40807	4T300FIMX20-M-11	20	1
F40808	4T300FIMX20-M-11	7	1
F40839	4T300FIMX20-M-11	6	1
F40889	4T300FIMX23-M-09	31	1
F40909	4T300FIMX20-M-05	50	1
F40933	4T300FIMX23-M-09	31	1
F40956	4T300FIMX23-M-09	31	1
F40997	4T300FIMX20-M-05	34	1
F48353	4T300FIMX23-M-09	18	1
F48368	4T300FIMX22-M-04	14	1
F48371	4T300FIMX23-M-02	29	1
F48372	4T300FIMX22-M-04	19	2
F48374	4T300FIMX23-M-02	26	2
F48400	4T300FIMX23-M-02	35	4
F49045	4T300FIMX20-M-01	10	4

F49818	4T300FIMX20-M-11	4	1
F49820.1	4T300FIAA22-M-06	5	2
F49821	4T300FIMX20-M-05	48	1
F49823	4T300FI23-M-10	8	2
F49832	4T300FIAA22-M-06	2	1
F49833	4T300FIMX20-M-11	13	1
F49841	4T300FIMX20-M-05	6	1
F49853	4T300FIMX20-M-11	33	1
	4T300FIMX22-M-03	7	1
F49869	4T300FIMX23-M-09	7	5
F49871	4T300FIMX22-M-04	17	1
	4T300FIMX23-M-02	18	2
F49874	4T300FIMX23-M-02	34	4
F49875	4T300FIMX20-M-01	9	2
F49883	4T300FIMX22-M-04	25	2
F49884	4T300FIMX22-M-04	30	1
F49913	4T300FIMX20-M-05	19	1
F49914	4T300FI23-M-10	3	1
F49920	4T300FIMX20-M-05	11	1



4T300FIMX23-M
MOTORE - ENGINE

-

F49925	4T300FIMX20-M-05	10	1
F49929	4T300FIMX20-M-11	21	8
F49937	4T300FIMX20-M-11	17	1
F49939	4T300FI23-M-10	7	2
F65104	4T300FIAA22-M-06	19	1
F66510	4T300FIMX20-M-05	29	1
F68145	4T300FIMX20-M-11	1	1
F70370	4T300FIMX20-M-07	42	1
F70404	4T300FIMX22-M-04	23	1
F70408	4T300FIMX22-M-04	28	1
F70413	4T300FIMX22-M-04	24	1
F70423	4T300FIMX22-M-04	18	1