



---

USES AND  
RACOMMENDS



[www.tmracing.it](http://www.tmracing.it)

---

TM Racing SpA - Via Fano, 6  
61122 Pesaro - ITALY  
Phone: +39 0721 25113

## 2T125MX22-M

MOTORE  
ENGINE

02/03/2022



## INFORMAZIONI GENERALI

Il presente catalogo serve per richiedere con esattezza le parti di ricambio.

Nelle ordinazioni indicare:

**1) Il numero di matricola del Telaio** che è stampigliato sul lato destro del canotto di sterzo. Nei modelli EN, SMR, SMR il numero di matricola è riportato anche su una targhetta posta sul lato sinistro (Vedi foto).

**2) il numero di serie del Motore.** E' posto sulla sinistra del motore tra la leva cambio e i coperchio accensione (Vedi foto).

**3) Il codice dei particolari** seguito dalla descrizione.

**4) Il colore** per i pezzi verniciati o comunque colorati.

Le indicazioni destra e sinistra si riferiscono ai lati del veicolo rispetto al senso di marcia.

Foto e disegni sono solo a scopo informativo e potrebbero non corrispondere esattamente alle caratteristiche dei prodotti.

## GENERAL INFORMATION

The present spare parts catalogue enables one to order exactly the right spare part.

When ordering specify:

**1) The frame serial number.** It is embossed on the right side of the steering metal tube. In the EN, SMR and SMR models, the serial number is also stated on a plate positioned on the left hand side (See photo).

**2) The engine serial numer.** It is located on the left side of the engine between the gear lever and the ignition cover (See photo).

**3) The part's code number** followed but its description.

**4) Indicate colour** for painted or colored parts.

References to right and left apply to the vehicle in terms of its direction of movement.

Photos and drawings are for informational purposes only and may not exactly match the characteristics of the products.

## NOTE – LEGENDA

**MY**

NOVITA' INTRODOTTA DIFFERENTE O NON PRESENTE NEL MODELLO DELL'ANNO PRECEDENTE

*PART DIFFERENT OR NOT PRESENT IN THE REVIOUS YEAR MODEL*

**5M**

MOTORE CON CAMBIO A 5 MARCE  
*ENGINE WITH 5 GEARS SPEED*

**6M**

MOTORE CON CAMBIO A 6 MARCE  
*ENGINE WITH 6 GEARS SPEED*

**KS**

MOTORE CON SOLO KICK STARTER  
*ENGINE WITH KICK STARTER ONLY*

**ES**

MOTORE CON AVVIAMENTO ELETTRICO  
*ENGINE WITH ELECTRIC STARTER*

**X**

RICAMBIO NON DISPONIBILE ALLA VENDITA  
*PART CAN NOT BE SOLD SEPARATELY*

Le illustrazioni riportate in questo manuale sono fornite solo come riferimento e possono variare dal prodotto effettivo,

Dati indicativi soggetti a modifiche senza impegno di preavviso.

The illustrations in this manual are for reference only and may vary from the actual product.

All data are subject to modification without prior notice.

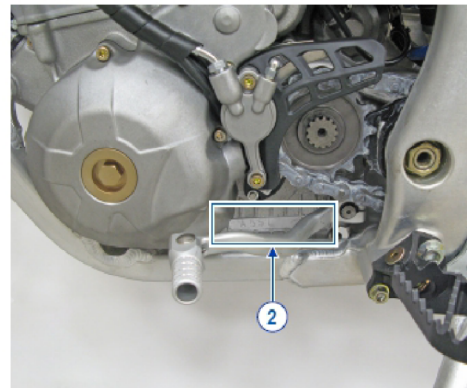
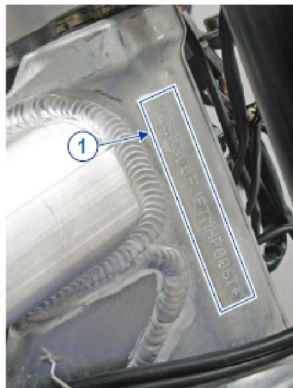



**2T125MX22-M**  
**MOTORE - ENGINE**

CILINDRO - CYLINDER.....	4
MOTORINO VALVOLA - ELECTRIC VALVE SYSTEM.....	7
ALBERO MOTORE - PISTONE - CRANKSHAFT - PISTON.....	9
ACCENSIONE - IGNITION.....	11
BASAMENTO - CRANKCASE.....	13
FORCHETTE CAMBIO - GEAR FORKS.....	15
FRIZIONE - CLUTCH.....	18
COPERCHI FRIZIONE - CLUTCH CASE.....	21
CAMBIO MX - GEARBOX MX.....	23
- .....	26



2T125MX22-M  
MOTORE - ENGINE

CILINDRO  
CYLINDER

1

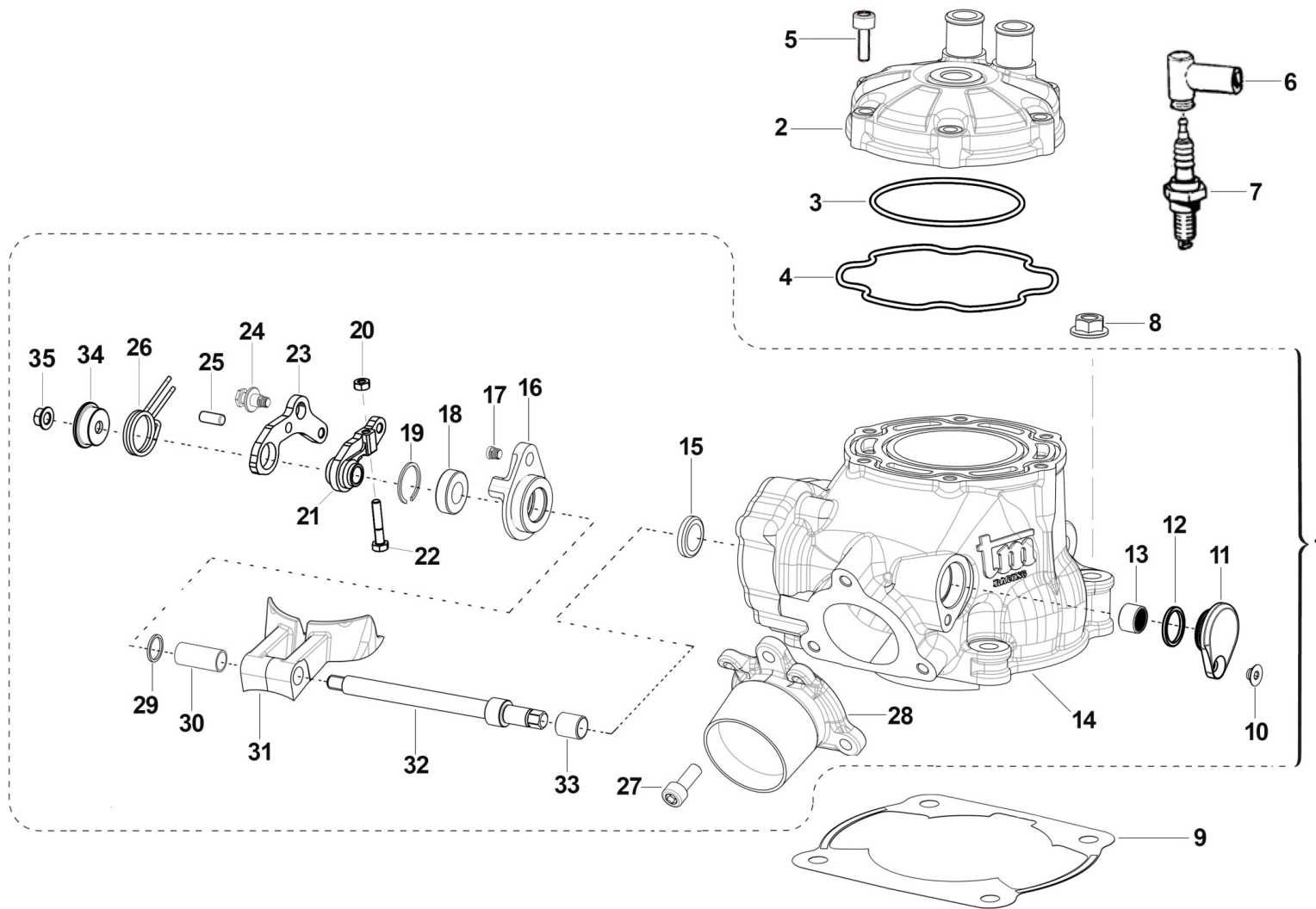



**2T125MX22-M**  
**MOTORE - ENGINE**

**CILINDRO**  
**CYLINDER**

1	01130	1		CILINDRO 125 2T MX MY20 CPL (CARB)	CYLINDER 125 2S MX MY20 ASSY
2	02026	1		TESTA 125 EN MOD. 2012	HEAD 125cc M.12-
3	12003	1		O RING TESTA 125 90/06KVK8-910 NBR	O-RING, HEAD 125 90/06 KV8910
4	12021	1		O RING PREFORMATO CIL.125/12->	O-RING, HEAD 125EV M. 2012
5	49358	6		VITE TE F/R 6X30 Ch.8	BOLT 6X30 T.8
6	21017	1		PIPETTA CANDELA NGK LB05EMH	CAP, NGK SPARK PLUG LB05EMH
7	06011	1		CANDELA NGK BR9EG	SPARK PLUG, NGK BR9EG
8	49640	4		DADO M 8 FLANGIATO CHIAVE 12	NUT 8mm, FLANGE
9	05530	1		GUARN. B/CIL 125 M.2012 0,10	GASKET, CYL 125EV M.12/-> 0,10
9	05531	1		GUARN. B/CIL 125 M.2012 0,15	GASKET, CYL 125EV M.12/-> 0,15
9	05532	1		GUARN. B/CIL 125 M.2012 0,20	GASKET, CYL 125EV M.12/-> 0,20
9	05533	1		GUARN. B/CIL 125 M.2012 0,30	GASKET, CYL 125EV M.12/-> 0,30
9	05534	1		GUARN. B/CIL 125 M.2012 0,40	GASKET, CYL 125EV M.12/-> 0,40
9	05535	1		GUARN. B/CIL 125 M.2012 0,50	GASKET, CYL 125EV M.12/-> 0,50
10	49399	1		VITE TSEI 5X12	BOLT TSEI 5x12
11	30217	1		TAPPO SX ALB.COM.VALV.PAL.125	SIDE COVER
12	F12308	1		O RING 17,5 - 1,5	O-RING 17,5 - 1,5
13	19060	1		ASTUCCIO A RULLI HK 1212	NEEDLE CAGE HK 1212
14	01129	1	MY20	CILINDRO 125 2T MX M2020 NUDO	CYLINDER 125 2S MX MY20
15	04115	1		PARAOLIO G 12X18X3	OIL SEAL 12x18x3
16	26258	1	MY20	FLANGIA PORTACUSC.ALB.VALV.250/300 IE	FLANGE, BEARING HOLDER
17	49757	1		VITE TBCE 5 X 12	BOLT TBCE 5X12
18	03156	1		CUSCINETTO V.SC.C.12 698LLU/5K	BUSH, EXHAUST VALVE 698LLU
19	49220	1		SEEGER INT.19	SEEGER I 19
20	49630	1	MY20	DADO M 4 (BASSO)	NUT 4mm, LOW
21	28108	1	MY20	LEVA INTERNA COMANDO VALVOLE EES-2 125/144 2020	LEVER, INTERNAL, VALVE
22	49874	1	MY20	VITE TE 4X16	BOLT TE 4X16
23	28263	1	MY20	LEVA ESTERNA COMANDO VALVOLE EES-2	LEVER, EXTERNAL, VALVE



**2T125MX22-M**  
**MOTORE - ENGINE**

**CILINDRO**  
**CYLINDER**

**1**

24	26168	1	MY20	PERNO MOLLA EES-2 16066	PIN, SPRING
25	F19536	1	MY20	RULLO D. 5 X 12 M6 DIN 6325	PIN 5X12
26	16066	1	MY20	MOLLA EES-2	SPRING EES-2
27	49355	3		VITE TE F/R 6X16 Ch.8	BOLT 6X16 T.8
28	13081	1		COLLETTORE SCA. 125 12/-> 3F	MANIFOLD EXHAUST 125cc 12->
29	26130.12	1		SPESS. REG. CIL.125 2012 1.2	SPACER CYL. 125 ->12 1.2
29	26130.13	1		SPESS. REG. CIL.125 2012 1.3	SPACER CYL. 125 ->12 1.3
29	26130.14	1		SPESS. REG. CIL.125 2012 1.4	SPACER CYL. 125 ->12 1.4
29	26130.15	1		SPESS. REG. CIL.125 2012 1.5	SPACER CYL. 125 ->12 1.5
29	26130.16	1		SPESS. REG. CIL.125 2012 1.6	SPACER CYL. 125 ->12 1.6
29	26130.17	1		SPESS. REG. CIL.125 2012 1.7	SPACER CYL. 125 ->12 1.7
29	26130.18	1		SPESS. REG. CIL.125 2012 1.8	SPACER CYL. 125 ->12 1.8
29	26130.19	1		SPESS. REG. CIL.125 2012 1.9	SPACER CYL. 125 ->12 1.9
30	26147	1	MY20	BOCCOLA DIST. CIL.250/300 2015	BUSH
31	22065.15	1		VALVOLE SCARICO 125 EV M.15/->	VALVES EXHAUST 125 2S EV 15->
32	28059	1		ALBERO COMANDO PALETTE 125	SHAFT, BOOSTER 125
33	19061	1		BOCCOLA IR 8X12X12.5	BUSH, IR 1X12X12,5
34	26167	1	MY20	PIATTELLO GUIDA MOLLA EES-2 16066	COLLAR, SPRING
35	49676	1	MY20	DADO M 6X1 FLANG. AUTOBL.ACC.	NUT, FLANGED M6 X 1 S.B.

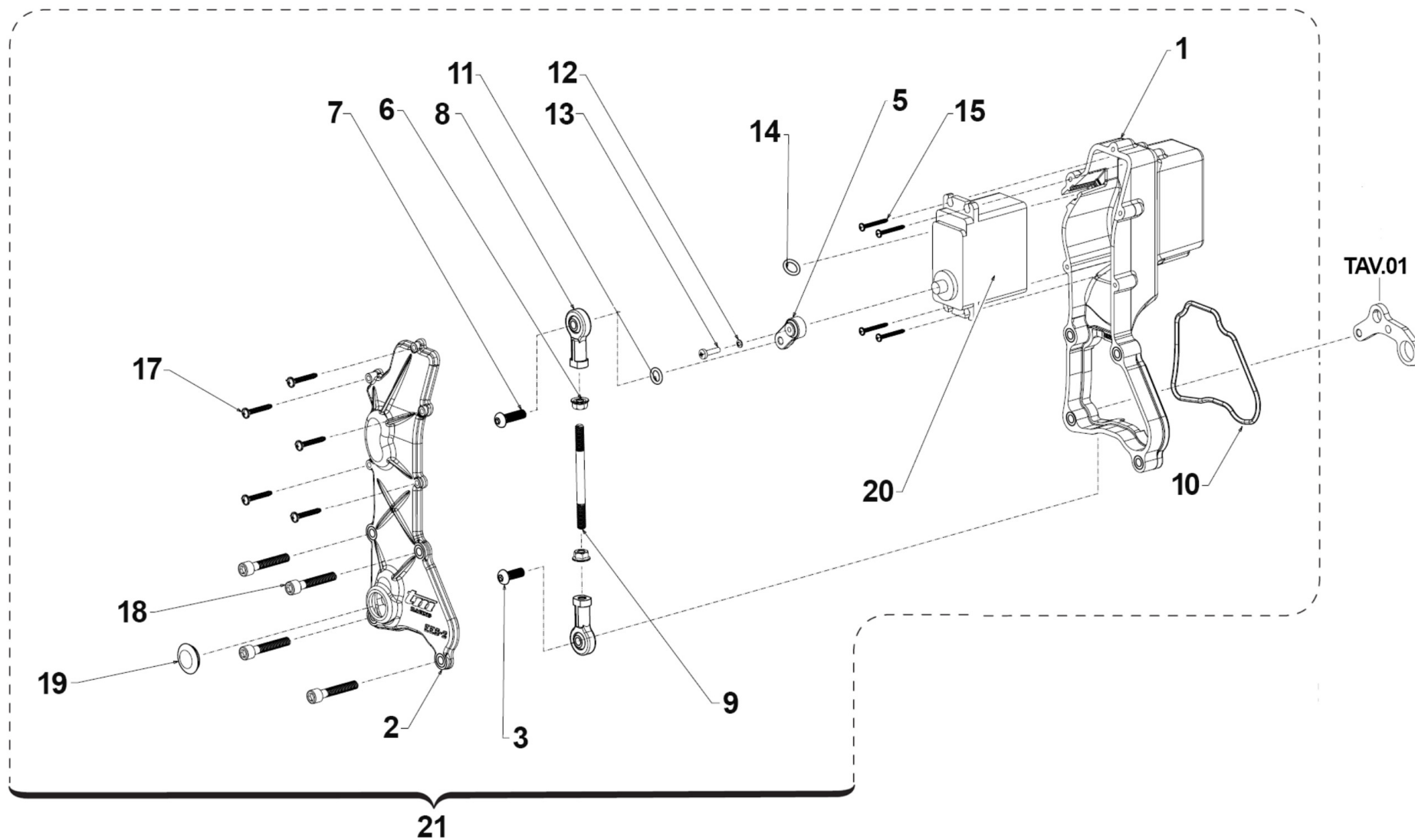



**2T125MX22-M**  
**MOTORE - ENGINE**

**MOTORINO VALVOLA**  
**ELECTRIC VALVE SYSTEM**

**2**

1	30291	1	CARTER EES-2 125/144 2T FI	CASE, PLASTIC, ENGINE VALVE
2	30392	1	COPERCHIO CARTER EES-2 125/144 2T FI	
3	49472	1	VITE TCEI 5X12 UNI 5931	BOLT TCEI 5X12
5	28266.0	1	LEVA SERVOMOTORE EES-2 DENTATURA 0	LEVER
5	28266.1	1	LEVA SERVOMOTORE EES-2 DENTATURA 1	LEVER
6	49632	2	DADO M 5 x 0,8 ZB	NUT 5mm
7	49929	1	VITE 10.9 TBCEI 5 x 18 UNI 7380	BOLT
8	72251	2	SNODO MECCANISCO VALVOLA EES-2 125/250/300	JOINT EXHAUST VALVE EES-2 250/300
9	28109	1	ASTINA COLLEGAMENTO UNIBALL EES-2 125/144 2020	ROD, UNIBALL 125/144 MY20
10	12042	1	O RING COP. VALVOLA EES-2	O-RING
11	F12301	1	O RING 106 4T PIOGGIA CAMBIO	O-RING, 106 GEAR F.S.
12	49124	1	RONDELLA SCHNORR ZIG. 2.5	
13	49881	1	VITE T.C. 2,5X12	
14	F12321	1	O RING BOCCOLA CENTR. CILINDRO	O-RING
15	49973	4	VITE STS-Plus KN6031 2.2X20 PLASTICA	BOLT
17	49919	5	VITE TCBL 3.0X 20 FL. X PLAST.	BOLT
18	49478	4	VITE TCEI 5X30 UNI 5931	BOLT TCEI 5X30
19	21009	1	TAPPO GOMMA COPERCHIO VALV.SC.	RUBBER, COVER
20	22500	1	SERVOMOTORE VALV.SCARICO HITEC	EL. ENGINE EXHAUST VALVE HITEC
21	22502.20	1	SERVOMOTORE V/SC. CPL 125/144 MY20	EL. ENGINE EXHAUST, 125/144 MY20 ASSY



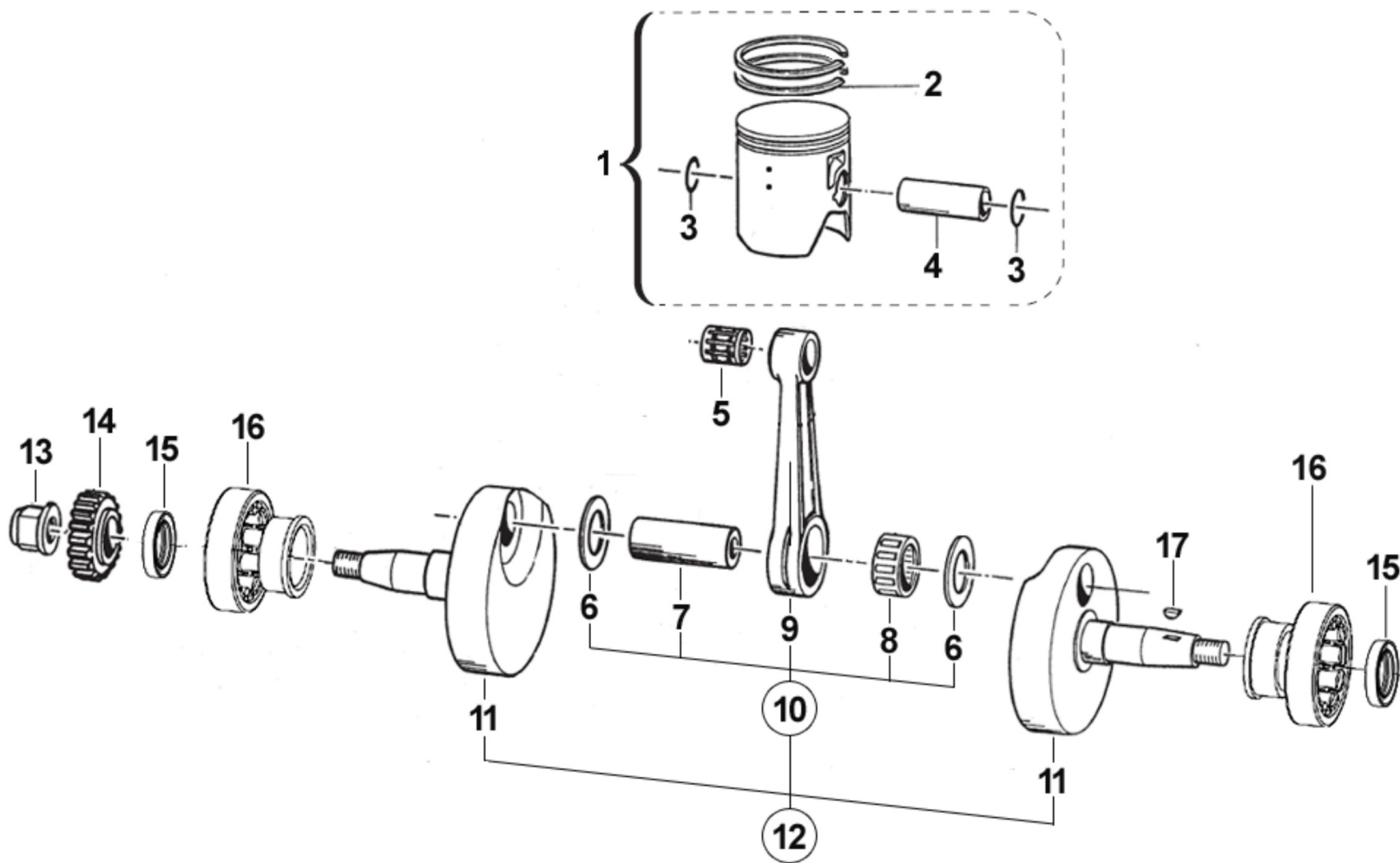



**2T125MX22-M**  
**MOTORE - ENGINE**

**ALBERO MOTORE - PISTONE**  
**CRANKSHAFT - PISTON**

1	10022.94	1	PISTONE 53.94 125 2014 2F(0,8)	PISTON 53.94 125CC M14 2 R.0,8
1	10022.95	1	PISTONE 53.95 125 2014 2F(0,8)	PISTON 53.95 125CC M14 2 R.0,8
1	10022.96	1	PISTONE 53.96 125 2014 2F(0,8)	PISTON 53.96 125 M.14-> 2R.0,8
1	10022.97	1	PISTONE 53.97 125 2014 2F(0,8)	PISTON 53.97 125 M.14-> 2R 0,8
1	10022.98	1	PISTONE 53.98 125 2014 2F(0,8)	PISTON 53.98 125 M.14-> 2R 0,8
2	11069	2	SEGMENTO 54,00 X 0,80 TPR	PISTON RING 54,00 X 0,80 TPR
3	09004.1	2	ANELLINO SPINOTTO PIST.125/144	CLIP, PISTON PIN 125 / 144
4	09008	1	SPINOTTO PISTONE 125 15X41F10	PIN, PISTON 125, 15x41 F10
5	19034	1	GABBIA SPINOTTO 15X19X17,3	TOP END B. 15X19X17,3
6	18239	2	RONDELLA ARGENTATA D.22 X 1 v2	WASHER, SILVER ID 22 X 1
7	18025	1	ASSE ACCOP. 22 X 50.4 F5 125K	CRANKPIN 22X50,4 H.5mm 125K
8	17015	1	GABBIA ARGENTATA 222815	SILVER CAGE 22X28X15
9	18053.2	1	BIELLA ASSE 22 FORG. NUDA 109,8	CONROD D.22mm FORGED 109,8
10	18125.2	1	BIELLA KZ10-B 22 CPL ASSE F.5	CONROD ASSY KZ10-B 22 PIN H.5
11	18241	1	COPPIA SEMIALBERI 125 MX/E '15	CRANKSHAFT SIDES
12	18242	1	ALBERO MOTORE 125 EV MX/E 15/-	CRANKSHAFT 125 EV MX/E M.15->
13	49094	1	DADO TRASMISS.125 06 M 14 X 1.25	NUT,CLUTCH CENT.14X1.25 125 06
14	40303	1	PIGNONE COPPIA PRIMARIA Z19 CR	PRIMARY DRIVE GEAR 19T MX
14	50030	1	ESTRATTORE PIGNONE COPPIA	PRIMARY GEAR PULLEY
15	04035	2	PARAOLIO 20x30x7 PTFE	OIL SEAL 20 x 30 x 7 PTFE
16	03029	2	CUSCINETTO BC1-1442 B	BUSH, BC1-1442 B KZ10
17	49010	1	CHIAVETTA VOLANO 13x5x3	WOODRUFF KEY

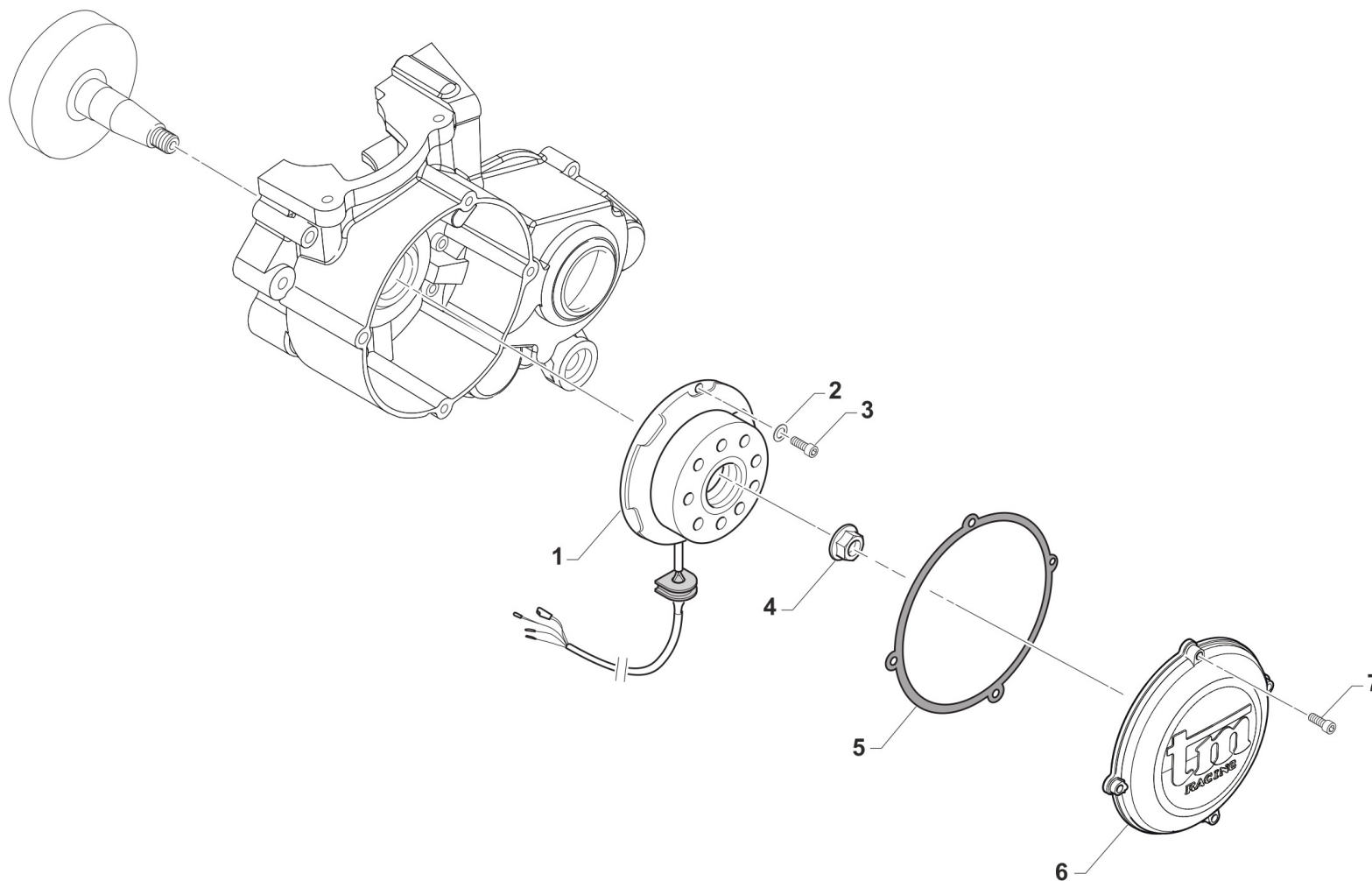

TM 0178.02



**2T125MX22-M**  
**MOTORE - ENGINE**

**ACCENSIONE**  
**IGNITION**

**4**

1	15230	1	GENERATORE KOK END 11 MX/E 12	GENERATOR KOK END 11 MX/E 12->
2	49603	2	RONDELLA M 6,4 X 12 X 1,6	WASHER 6x12
3	49484	2	VITE TCEI 6X20	BOLT TCEI 6X20
4	49056	1	DADO ACCENS 100/TAG/KZ 125MX/E	NUT, IGNITION 100cc
5	05516	1	GUARN. COP.ACC. 80/125 KOKUSAN	GASKET, KOK.IGNIT.COV. 80/125
6	30211	1	COP. ACC. MX 125/144 06/11 E11	COVER, IGNITION MX 80/125 2006 KOK.
7	49477	4	VITE TCEI 5X25 UNI 5931	BOLT TCEI 5X25





**2T125MX22-M**  
**MOTORE - ENGINE**

**BASAMENTO**  
**CRANKCASE**

1	49640	4	DADO M 8 FLANGIATO CHIAVE 12	NUT 8mm, FLANGE
2	49020	2	PRIGIONIERO CIL.48 mm 80/125	STUD CYL.48mm 80/125cc
3	49027	2	PRIGIONIERO CIL.58 KV-K7-K8-K9	STUD 8 X 58 mm
4	26043	1	GRANO CARTER ANT. 14 X 14	GRUB SCREW 14X14
5	26044	1	GRANO CENTRAGGIO MOTOR.10X13,6	GRUB SCREW 10X13,6
6	49103	1	RONDELLA 14X20X1,5 ALLUMINIO	WASHER, 14 X 20 X 1.5 ALUMINUM
7	49301	1	TAPPO OLIO C/CALAM. 2T	OIL PLUG WITH MAGNET
8	30176.15	1	BASAMENTO MOTORE 125 EV 2015	CRANKCASE, 125
9	05277	1	GUARN. PACCO LAMELLE VFORCE 3	GASKET, REED BLOCK VFORCE 3
10	20061	1	PACCO LAM 125/144 VF3 M. 08/->	REEDS BOX VF3 125/144 M. 08/->
11	20074	1	LAMELLE V-FORCE3 125/144 07/->	REEDS, V-FORCE3 125/144 07/->
12	12026	1	O RING CONVOGLIATORE 125 13086	O-RING INLET MANIFOLD 125 13086
13	13086	1	COLLETTORE AI ASP. 125cc 2013	ALL. INTAKE MANIFOLD 125 cc M.13->
14	49484	2	VITE TCEI 6X20	BOLT TCEI 6X20
15	49484	2	VITE TCEI 6X20	BOLT TCEI 6X20
16	13009	1	MANICOTTO COLLETTORE ASP.97/14	MANIFOLD RUBBER,INTAKE M.97/14
17	51054	2	FASCETTA SM9 D.52	CLAMP SM9 D.52mm
18	04034.15	1	KIT PARAOLI 125 EV M.2015	OIL SEALS 125cc EV M.15->
19	05621	1	KIT GUARN. + OR 125 2012 V.EL	GASKETS + OR 125cc M.12->

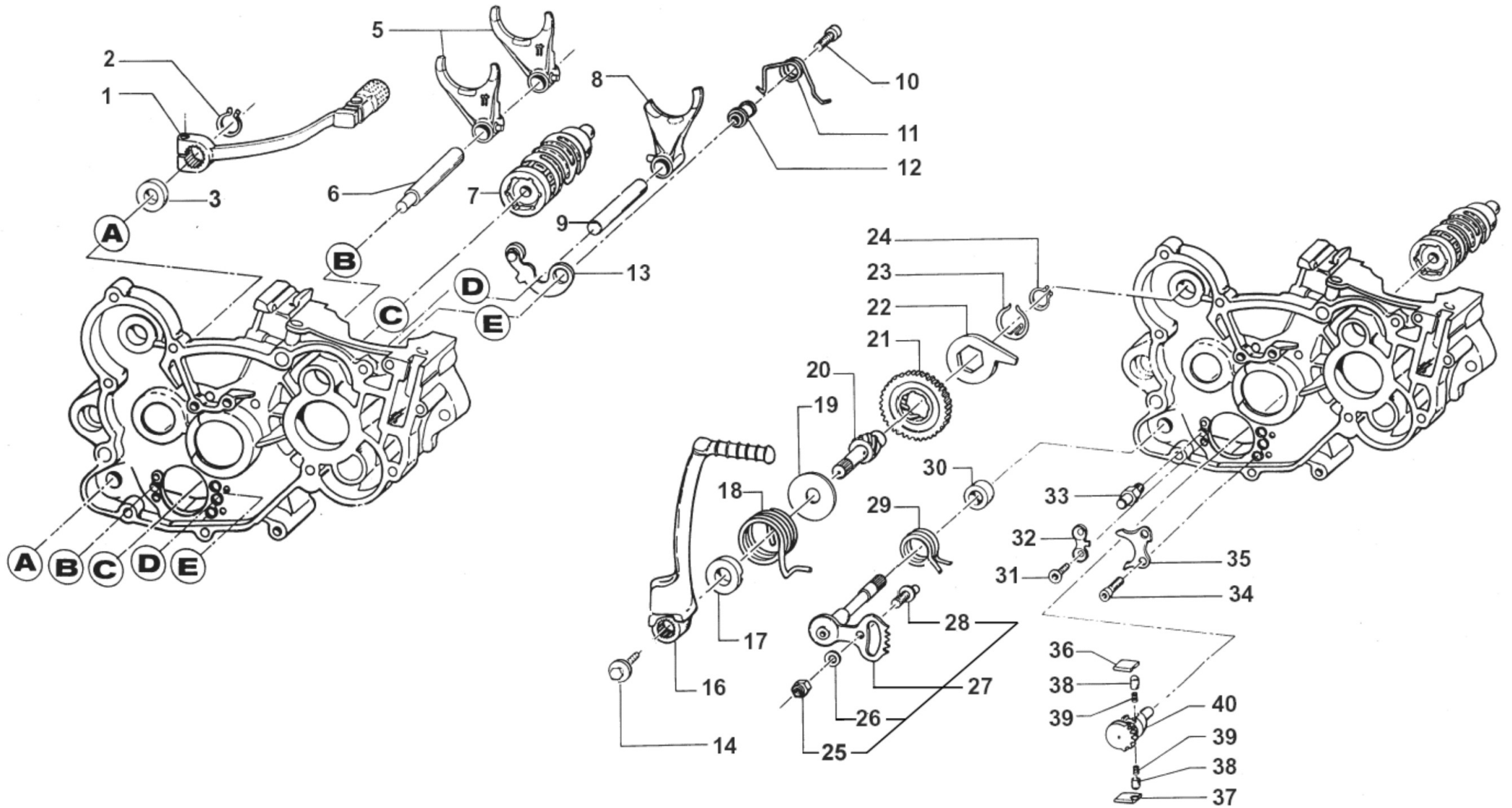



**2T125MX22-M**  
**MOTORE - ENGINE**

**FORCHETTE CAMBIO**  
**GEAR FORKS**

1	43049	1		LEVA CAMBIO 250 / 300 2T E.S. 19	GEAR LEVER 250 / 300 T.STR. EL.ST. M.19->
2	49212	1		SEEGER E12 LEVA CAMBIO	CIRCLIP D.12 - EXTERNAL
3	04004	1		PARAOLIO POMPA H2O-LEVA CAMBIO	OIL SEAL 12 x 22 x 5
5	F33314	2		FORCHETTA A/S 125/250/300 CROM	SHIFT FORK SECONDARY 125/250CR
6	33256	1		PERNO FORCH.ALB.SEC. 250 / 125.99	AXEL, COUNTERSHAFT FORK 250cc
7	33004	1	MY20	ALBERO DESM.125 INTEGR. 6M CPL 125/144 6 M. CPL DI F26476	GEAR DRUM 125 6SP. 125/144 ASSY F26476
8	33016	1		FORCHETTA ALB.PRIM.125 PRT.CRM	SHIFT FORK MAINSHAFT 125 CROM.
9	33255	1		PERNO FORCH.ALB. PRIM.250 / 125.99	AXEL, MAINSHAFT FORK 250cc
10	49485	1		VITE TCEI 6X25 UNI 5931	BOLT TCEI 6x25
11	16252.12	1		MOLLA BLOCCAMARCE 125/250 2012	SPRING, STOP GEAR 125/250 M.12
12	26007	1		DISTANZIALE MOLLA BLOCCAMARCE	SPACER, STOP GEAR SPRING
13	26063.12	1		PIASTRINO BLOCCAMARCE 2012 CPL	PLATE STOP GEAR ASSY M.12->
14	49368	1		VITE TE F/R 6X10 LEVA M/M	BOLT 6X10 (Kich Starter)
16	43038	1		LEVA M/M 80/125 M. 99/->	LEVER, KICK STARTER 125 99/->
17	26005	1		DISTANZIALE MOLLA M/M	SPACER, KICK STARTER SPRING
18	16008	1		MOLLA M/M 80 / 125 / 144 cc	SPRING, KICK STARTER
19	48008	1		RONDELLA ALBERO MESSA IN MOTO	WASHER, KICK STARTER SHAFT
20	28051	1		ALBERO MESSA IN MOTO 125/144 96/18	SHAFT, KICK STARTER 125 96/05
21	40350	1		INGRANAGGIO SCORREVOLE M/M 125 / 144	SLIDING GEAR, KICK STARTER 125
22	26254	1		LEVA BATTUTA M/M 125/250 96/->	STOPPER, KICK STARTER
23	16006	1		MOLLA X INGRANAGGIO M/M	SPRING, KICKSTART SLIDING GEAR
24	49214	1		SEEGER E15 INGRANAGGIO M/M	CIRCLIP GEAR K.S. 15mm
25	49638	1		DADO M 6 ALTO AUTOBLOCCANTE	NUT 6mm, HIGHT SELF-LOCKING
26	49603	1		RONDELLA M 6,4 X 12 X 1,6	WASHER 6x12
27	28100	1		ALBERO COMANDO ING. P.TACRIC.	SHAFT, GEARSHIFT
28	26050	1		BATTUTA ECCENTRICA	ADJUSTER SELECTOR SHAFT
29	16009	1		MOLLA RITORNO LEVA CAMBIO 32CR	SPRING, RETURN GEAR LEVER 3,2
30	26006	1		DISTANZIALE MOLLA LEVA CAMBIO	SPACER, GEAR LEVER SPRING





**2T125MX22-M**  
**MOTORE - ENGINE**

**FORCHETTE CAMBIO**  
**GEAR FORKS**

31	49405	2	VITE TSEI 6X20 UMB.5933 10.9	BOLT TSEI 6x20 U.5933 10.9
32	26022	1	PIASTRINO FINE CORSA	PLATE END STROKE GEAR LEVER
33	26051	1	BATTUTA FISSA LEVA CAMBIO INT.	PLATE INT. END STROKE GEAR LEVER
34	49483	2	VITE TCEI 6X16 UNI 5931	BOLT TCEI 6X16
35	26021	1	PIASTRINO RIENTRO CRICCHETTI	PLATE, RATCHET
36	26060	1	CRICCHETTO CAMBIO SUPERIORE	RATCHET UP, GEAR
37	26061	1	CRICCHETTO CAMBIO INFERIORE	RATCHET DOWN, GEAR
38	26062	2	PUNTALE PER CRICCHETTO CAMBIO	PIN, RATCHET GEAR
39	16012	2	MOLLA PER PUNTALE	SPRING, GEARBOX PIN
40	40310	1	INGRANAGGIO PORTACRICCHETTI	DRUM SHIFTER GEAR

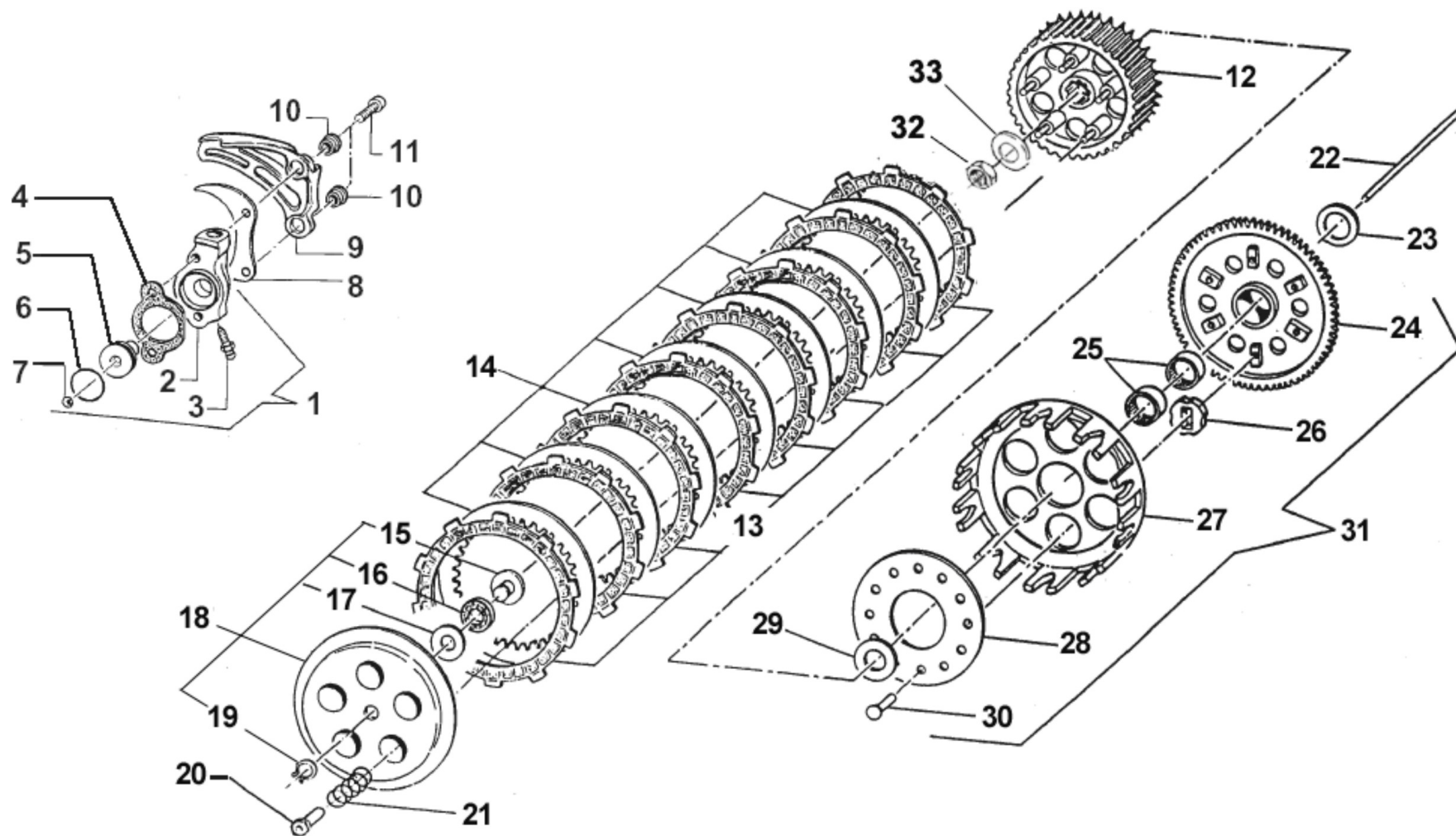



**2T125MX22-M**  
**MOTORE - ENGINE**

**FRIZIONE**  
**CLUTCH**

1	30206	1	COP. FRIZ/IDR 85/125 95/-> CPL	OUTPUT H.CLUTCH CYLINDER CPL.
2	30205	1	COP. FRIZ/IDR 80/125 95/11 NUD	OUTPUT H.CLUTCH CYLINDER
3	35264	1	VITE SPURGO OLIO FRIZ.IDR.6X1	SCREW AIR BLED HYDRAUL.CLUTCH
4	05509	1	GUARN. POMPA FRIZ.IDR. 80/125	GASKET, HYDRAULIC CLUTCH80/125
5	35125	1	PISTONE POMPA FRIZ. 125 95/->	PISTON, CLUTCH PUMP 125 95/04
6	12259	1	O RING PISTONE FR.125/250VERDE	O-RING, CLUTCH PISTON 125/250
7	19052	1	SFERA 8 X FRIZIONE 250 5/16"	BALL, IDR. CLUTCH PUMP
8	40022	1	PROTEZIONE ERGAL PIGNONE CAT.	PROTECTION, GEAR CHAIN ERGAL
9	40029	1	PROTEZIONE PIGNONE 09/-> PLAST	PROTECTION FRONT SPROCKET09/13
10	26212	2	BOCCOLA PROT. PIGNONE 125 F.6	COLLAR, SPROCKET 125cc H.6
11	49486	2	VITE TCEI 6X30 UNI 5931	BOLT TCEI 6X30
12	25099.14	1	TAMBURELLO FRIZIONE 125 2014	CLUTCH CENTRE 125cc M.14->
12	50124	1	CHIAVE FRIZ. 85/125 + KART CPL	CLUTCH TOOL 85/125cc + KART
13	35012	8	DISCO FRIZ. GUARN.CR/E M.93->	CLUTCH PLATE, FIBER MX/E 93/->
14	35019	7	DISCO FRIZ. ACC. 1mm 99/05	CLUTCH PLATE, STEEL 1mm 99/05
15	26001	1	REGGISPINTA FRIZIONE	CLUTCH THRUST
16	19020	1	GABBIA A RULLI RAD. AXK 1024	NEEDLE CAGE AXK 1024, RADIAL
17	19021	1	RONDELLA X GABBIA RULLI AS1024	WASHER, NEEDLE CAGE AS 1024
18	35025	1	PIATTO SPING.FRIZ 125/KART CPL	PLATE, CLUTCH PRESSURE ASSY
19	49211	1	SEEGER E10x1 ANELLO PIATT.REG.	CIRCLIP D.8,4 - EXTERNAL
20	49057	5	DADO FRIZIONE ERGAL KZ10	NUT, CLUTCH KZ10 ERGAL
21	16020	5	MOLLA FRIZIONE 125 C/E 03/08BA	SPRING, CLUTCH 125 MX/E 03/->
22	35043	1	ASTINA FRIZ. IDR. 125 M.99/10	ROD, HYDR.CLUTCH 125 M. 99/04
23	48003	1	SPESSORE COP.PRIM.30X20X2	SPACER 30X20X2 PRIMARY GEAR
24	40402	1	COPPIA PRIM. 125 Z63	PRIMARY GEAR 63T, 125cc
25	19013	2	GABBIA A RULLI K 20X24X12	NEEDLE CAGE 20 X 24 X 12
26	21005	6	GOMMINO PARASTRAPPI FRIZIONE	RUBBER, CLUTCH BASKET
27	25000	1	CAMPANA FRIZ.125 M.91/96 99/13	CLUTCH BASKET 125 91/96 99/05



**2T125MX22-M**  
**MOTORE - ENGINE**

**FRIZIONE**  
**CLUTCH**

28	35026	1	DISCO BATTUTA GOMM. FRIZ.KZ10B	DISC STOP RUBBERS CLUTCH KZ10B
29	48002	1	SPESSORE COP.PRIM.30X18X3	SPACER 30x18x3
30	49727	6	VITE PARASTRAPPI K9 M7X1X12.5	SCREW, M7X1X12,5 K9 ENGINE
31	40409	1	COPPIA PRIM. 125 Z63 CPL 99/-> 93/96	PRIM.GEAR 63T,125 Comp. 99/04
32	49052	1	DADO TAMBURELLO FRIZIONE	NUT, CLUTCH CENTER
33	49127	1	MOLLA A TAZZA DIN 2093 28X14,2X1,25	DISC SPRING DIN 2093 28x14,2x1,25



2T125MX22-M  
MOTORE - ENGINE

COPERCHI FRIZIONE  
CLUTCH CASE

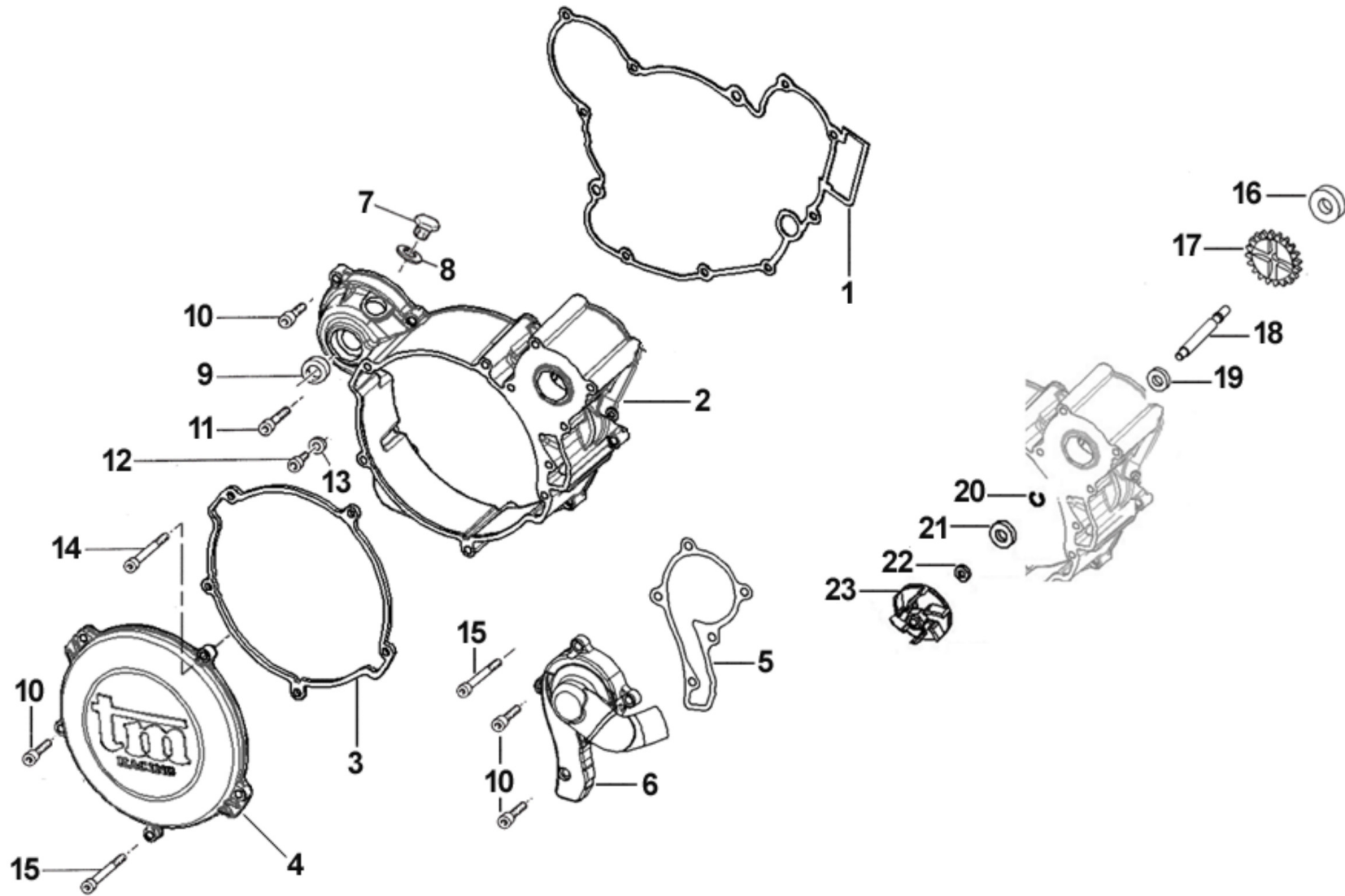



**2T125MX22-M**  
**MOTORE - ENGINE**

**COPERCHI FRIZIONE**  
**CLUTCH CASE**

1	05527	1	GUARN. COP.FRIZ. INT.125 06/->	GASKET, CLUTCH CASE 125 06/->
2	30174	1	CARTER FRIZIONE 125 M.12/->	CLUTCH COVER 125 M.12->
3	05526	1	GUARN. COP.FRIZ. EST.125 06/->	GASKET, EXT.CLUTCH COVER 125/6
4	30187	1	COPERCHIETTO FRIZ. 125 M.2006	COVER, CLUTCH, EXT. 125 06/->
5	05528	1	GUARN. POMPA ACQUA 125 2006	GASKET WATER PUMP 125cc 2006
6	30194.06	1	COPERCHIO POMPA H2O CR/E 06/->	WATER PUMP COVER MX/E M.2006
7	49300	1	TAPPO CARICO OLIO	OIL PLUG, FILL
8	49103	1	RONDELLA 14X20X1,5 ALLUMINIO	WASHER, 14 X 20 X 1.5 ALUMINUM
9	04005	1	PARAOLIO ALBERINO M/M 15x24x7	OIL SEAL 15 x 24 x 7
10	49476	12	VITE TCEI 5X20 UNI 5931	BOLT TCEI 5X20
11	49477	1	VITE TCEI 5X25 UNI 5931	BOLT TCEI 5X25
12	49480	1	VITE TCEI 6X10 UNI 5931	BOLT TCEI 6X10
13	49104	1	RONDELLA 6 x 10 x 1,5 ALLUMINIO	WASHER 6 x 10 x 1.5 ALUMINUM
14	49594	1	VITE TCEI 5X85 UNI 5931	SCREW TCEI 5X85
15	49595	3	VITE TCEI 5X80	BOLT TCEI 5X80
16	03025	1	CUSCINETTO 626 C3 POMPA H2O 06	BUSH, WATER PUMP 626 C3
17	40071	1	INGR COMANDO POMPA H2O 125 '12	GEAR, WATERPUMP 125 M.12/->
18	28062	1	ALBERINO POMPA ACQUA 125 2012	SHAFT, WATERPUMP 125 M.12/->
19	03014	1	CUSCINETTO 608 ZC3 POMPA SCHER	BUSH, WATER PUMP 608 Z C3
20	49215	1	SEEGER I22 POMPA ACQUA	CIRCLIP D.22 WATER PUMP
21	04017	1	PARAOLIO CENTRIFUGA 06 +MF1TAG	OIL SEAL 8 X 22 X 7 TC
22	49689	1	RONDELLA 6 X 12 SP. 1.2	WASHER 6x12 sp. 1,2
23	28009	1	GIRANTE POMPA ACQUA 2006/08	IMPELLER, WATER PUMP M.06/->

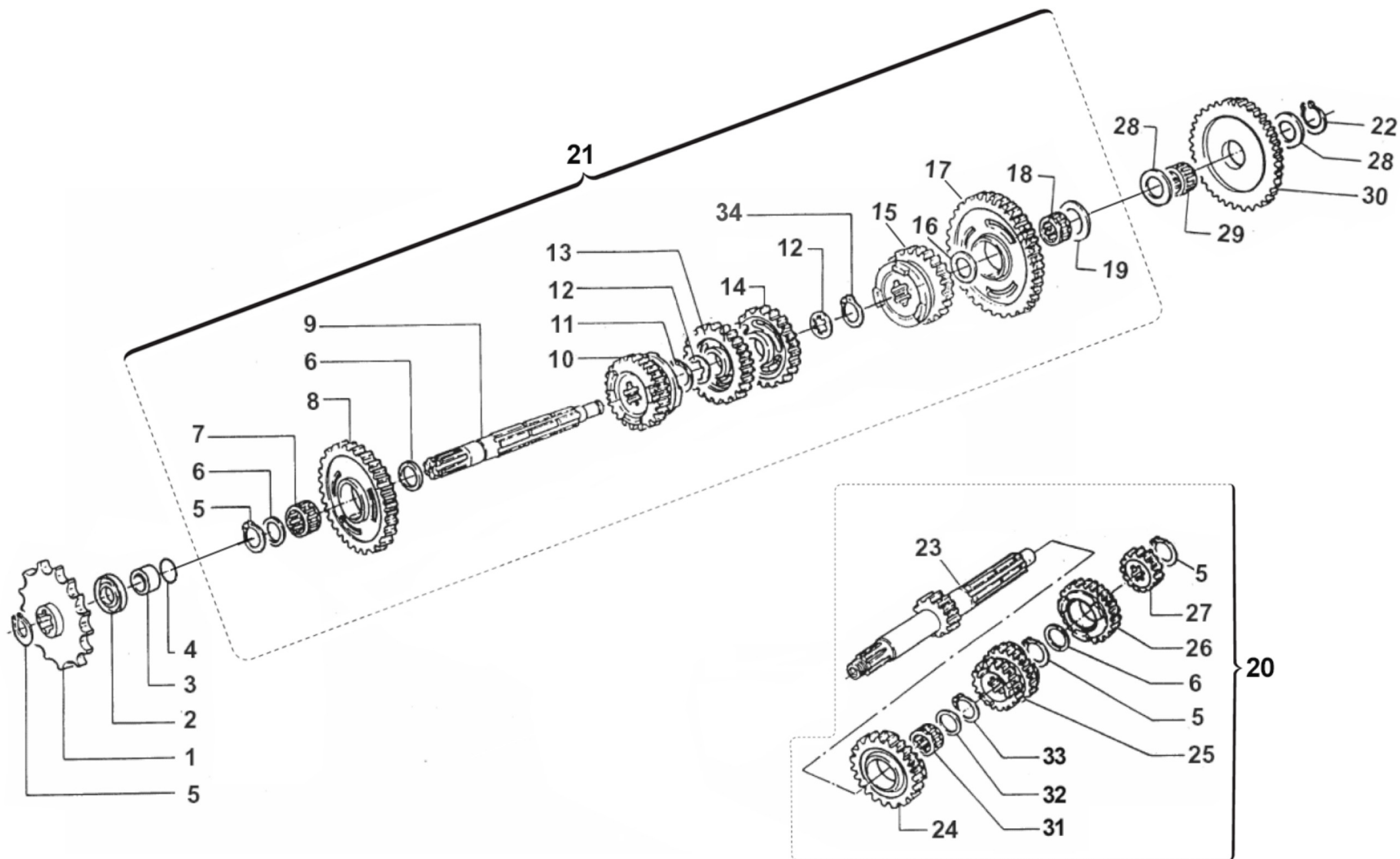



**2T125MX22-M**  
**MOTORE - ENGINE**

**CAMBIO MX**  
**GEARBOX MX**

1	40024	1		PIGNONE CAT. Z 11 BR12 M.00/->	SPROCKET 11T, DRIVE M.00/10
1	40025	1		PIGNONE CAT. Z 12 BR12 M.00/->	SPROCKET 12T, DRIVE 125 00/->
1	40026	1		PIGNONE CAT. Z 13 BR12 M.00/->	SPROCKET 13T, DRIVE 125 00/->
2	04003	1		PARAOLIO PIGN.CATENA (26x37x7)	OIL SEAL 26 x 37 x 7
3	26002.1	1		DISTANZIALE PIGNONE (MOTO)	SPACER, MOTORCYCLE GEAR
4	12019	1		O RING PIGNONE CATENA	O-RING, DRIVE GEAR 2075
5	49216	4		SEEGER E20 PIGN.-CAMBIO-COPPIA	CIRCLIP D.20 - EXTERNAL
6	48013	3		RASAMENTO A/S 27X20X0,7	SPACER, 27x20x0,7
7	19012	1		GABBIA A RULLI K 20X24X10	BUSH NEEDLE CAGE 20 X 24 X 10
8	40708	1		INGR A.S. 2a Z 29 CR/E 90	GEAR, 2TH (29T) COUNTERSH.CR/E
9	40462	1		ALBERO SECONDARIO SCAN. 12	COUNTERSHAFT BR 12
10	40712	1	MY20	INGR A.S. 6a Z 22 CR/90	GEAR, 6TH(22T)COUNTERSH.MX/E90
11	49217	1		SEEGER E22 ANELLO ALB/S	CIRCLIP D.22 - COUNTERSHAFT
12	48011	2		RASAMENTO DENT.A/S 27X22X0,75	SPACER, 27x22x0,75
13	40710	1		INGR A.S. 4a Z 25 CR/E 90	GEAR, 4TH(25T)COUNTERSH.MX/E90
14	40709	1		INGR A.S. 3a Z 27 CR/E 90	GEAR, 3RD(27T)COUNTERSH.MX/E90
15	40510	1		INGR A.S. 5a Z 24 CR/E 90	GEAR, 5TH (24T) COUNTERSHAFT
16	48012	1		RASAMENTO A/S M/M SPESS.0,5	SPACER, 26x17x0,5
17	40470	1		INGRANAGGIO A.S. 1a Z 31 MX	GEAR 1St M X (31T) COUNTERSHAFT
18	19011	1		GABBIA A RULLI K 17X21X10	BUSH CAGE 17 X 21 X 10
19	48010	1		RASAMENTO ALB/S.28X15X0,5 INGI	SPACER, 28x15x0,5
20	40001	1	MY20	ALBERO PRIMARIO CPL 125 MX 6M	PRIMARY SHAFT ASSY 125 MX
21	40002	1	MY20	ALBERO SECONDARIO CPL 125 MX 6M	
22	49214	1		SEEGER E15 INGRANAGGIO M/M	CIRCLIP GEAR K.S. 15mm
23	40713	1		ALBERO PRIMARIO Z 14 MX RINF.	MAINSHAFT MX 14T
24	40440	1		INGR. A.P. 5a Z 22 K9B/C 10 CR/E90	GEAR, 5TH (22T) MAINSHAFT
25	40702	1		INGR A.P. 3/4a Z 18/20 CR/E 90	GEAR, 3/4TH(18/20T)MAINSH.MX/E
26	40704	1	MY20	INGR A.P. 6a Z 23 CR/90	GEAR, 6TH (23T)MAINSHAFT MX/90





**2T125MX22-M**  
**MOTORE - ENGINE**

**CAMBIO MX**  
**GEARBOX MX**

27	40701	1	INGR A.P. 2a Z 16 CR/E 90	GEAR, 2ND (16T) MAINSH.MX/E 90
28	48004	2	SPESSORE INGRANAGGIO M/M	SPACER, K.STARTER GEAR
29	19010	1	GABBIA A RULLI K 15X19X10	BUSH NEEDLE CAGE 15 X 19 X 10
30	40351	1	INGRANAGGIO LIBERO M/M 125 / 144	GEAR, KICK STARTER 125
31	19071	1	GABBIA A 20X24X10 IN DUE META'	NEEDLE CAGE 20X24X10 TWO PIEC.
32	48041	1	RASAMENTO A/P 27.5X21X1 KZ10B	SPACER, MAINSHAFT 27,5X21X1 KZ
33	49222	1	SEEGER E 21 mm	CIRCLIP D.21 - EXTERNAL
34	49217.1	1	SEEGER RETTIFICATO PER 40510	SEEGER RING FOR CODE 40510



**2T125MX22-M**  
**MOTORE - ENGINE**

-

01129	2T125MX20-M-01	14	1
01130	2T125MX20-M-01	1	1
02026	2T125MX20-M-01	2	1
03014	2T12520-M-08	19	1
03025	2T12520-M-08	16	1
03029	2T12520-M-03	16	2
03156	2T125MX20-M-01	18	1
04003	2T125MX20-M-09	2	1
04004	2T125MX20-M-06	3	1
04005	2T12520-M-08	9	1
04017	2T12520-M-08	21	1
04034.15	2T125MX22-M-05	18	1
04035	2T12520-M-03	15	2
04115	2T125MX20-M-01	15	1
05277	2T125MX22-M-05	9	1
05509	2T12520-M-07	4	1
05516	2T125MX22-M-04	5	1
05526	2T12520-M-08	3	1
05527	2T12520-M-08	1	1
05528	2T12520-M-08	5	1
05530	2T125MX20-M-01	9	1
05531	2T125MX20-M-01	9	1
05532	2T125MX20-M-01	9	1
05533	2T125MX20-M-01	9	1
05534	2T125MX20-M-01	9	1
05535	2T125MX20-M-01	9	1
05621	2T125MX22-M-05	19	1
06011	2T125MX20-M-01	7	1

09004.1	2T12520-M-03	3	2
09008	2T12520-M-03	4	1
10022.94	2T12520-M-03	1	1
10022.95	2T12520-M-03	1	1
10022.96	2T12520-M-03	1	1
10022.97	2T12520-M-03	1	1
10022.98	2T12520-M-03	1	1
11069	2T12520-M-03	2	2
12003	2T125MX20-M-01	3	1
12019	2T125MX20-M-09	4	1
12021	2T125MX20-M-01	4	1
12026	2T125MX22-M-05	12	1
12042	2T12522-M-02	10	1
12259	2T12520-M-07	6	1
13009	2T125MX22-M-05	16	1
13081	2T125MX20-M-01	28	1
13086	2T125MX22-M-05	13	1
15230	2T125MX22-M-04	1	1
16006	2T125MX20-M-06	23	1
16008	2T125MX20-M-06	18	1
16009	2T125MX20-M-06	29	1
16012	2T125MX20-M-06	39	2
16020	2T12520-M-07	21	5
16066	2T125MX20-M-01	26	1
16252.12	2T125MX20-M-06	11	1
17015	2T12520-M-03	8	1
18025	2T12520-M-03	7	1
18053.2	2T12520-M-03	9	1

18125.2	2T12520-M-03	10	1
18239	2T12520-M-03	6	2
18241	2T12520-M-03	11	1
18242	2T12520-M-03	12	1
19010	2T125MX20-M-09	29	1
19011	2T125MX20-M-09	18	1
19012	2T125MX20-M-09	7	1
19013	2T12520-M-07	25	2
19020	2T12520-M-07	16	1
19021	2T12520-M-07	17	1
19034	2T12520-M-03	5	1
19052	2T12520-M-07	7	1
19060	2T125MX20-M-01	13	1
19061	2T125MX20-M-01	33	1
19071	2T125MX20-M-09	31	1
20061	2T125MX22-M-05	10	1
20074	2T125MX22-M-05	11	1
21005	2T12520-M-07	26	6
21009	2T12522-M-02	19	1
21017	2T125MX20-M-01	6	1
22065.15	2T125MX20-M-01	31	1
22500	2T12522-M-02	20	1
22502.20	2T12522-M-02	21	1
25000	2T12520-M-07	27	1
25099.14	2T12520-M-07	12	1
26001	2T12520-M-07	15	1
26002.1	2T125MX20-M-09	3	1
26005	2T125MX20-M-06	17	1



**2T125MX22-M**  
**MOTORE - ENGINE**

-

26006	2T125MX20-M-06	30	1
26007	2T125MX20-M-06	12	1
26021	2T125MX20-M-06	35	1
26022	2T125MX20-M-06	32	1
26043	2T125MX22-M-05	4	1
26044	2T125MX22-M-05	5	1
26050	2T125MX20-M-06	28	1
26051	2T125MX20-M-06	33	1
26060	2T125MX20-M-06	36	1
26061	2T125MX20-M-06	37	1
26062	2T125MX20-M-06	38	2
26063.12	2T125MX20-M-06	13	1
26130.12	2T125MX20-M-01	29	1
26130.13	2T125MX20-M-01	29	1
26130.14	2T125MX20-M-01	29	1
26130.15	2T125MX20-M-01	29	1
26130.16	2T125MX20-M-01	29	1
26130.17	2T125MX20-M-01	29	1
26130.18	2T125MX20-M-01	29	1
26130.19	2T125MX20-M-01	29	1
26147	2T125MX20-M-01	30	1
26167	2T125MX20-M-01	34	1
26168	2T125MX20-M-01	24	1
26212	2T12520-M-07	10	2
26254	2T125MX20-M-06	22	1
26258	2T125MX20-M-01	16	1
28009	2T12520-M-08	23	1
28051	2T125MX20-M-06	20	1

28059	2T125MX20-M-01	32	1
28062	2T12520-M-08	18	1
28100	2T125MX20-M-06	27	1
28108	2T125MX20-M-01	21	1
28109	2T12522-M-02	9	1
28263	2T125MX20-M-01	23	1
28266.0	2T12522-M-02	5	1
28266.1	2T12522-M-02	5	1
30174	2T12520-M-08	2	1
30176.15	2T125MX22-M-05	8	1
30187	2T12520-M-08	4	1
30194.06	2T12520-M-08	6	1
30205	2T12520-M-07	2	1
30206	2T12520-M-07	1	1
30211	2T125MX22-M-04	6	1
30217	2T125MX20-M-01	11	1
30291	2T12522-M-02	1	1
30392	2T12522-M-02	2	1
33004	2T125MX20-M-06	7	1
33016	2T125MX20-M-06	8	1
33255	2T125MX20-M-06	9	1
33256	2T125MX20-M-06	6	1
35012	2T12520-M-07	13	8
35019	2T12520-M-07	14	7
35025	2T12520-M-07	18	1
35026	2T12520-M-07	28	1
35043	2T12520-M-07	22	1
35125	2T12520-M-07	5	1

35264	2T12520-M-07	3	1
40001	2T125MX20-M-09	20	1
40002	2T125MX20-M-09	21	1
40022	2T12520-M-07	8	1
40024	2T125MX20-M-09	1	1
40025	2T125MX20-M-09	1	1
40026	2T125MX20-M-09	1	1
40029	2T12520-M-07	9	1
40071	2T12520-M-08	17	1
40303	2T12520-M-03	14	1
40310	2T125MX20-M-06	40	1
40350	2T125MX20-M-06	21	1
40351	2T125MX20-M-09	30	1
40402	2T12520-M-07	24	1
40409	2T12520-M-07	31	1
40440	2T125MX20-M-09	24	1
40462	2T125MX20-M-09	9	1
40470	2T125MX20-M-09	17	1
40510	2T125MX20-M-09	15	1
40701	2T125MX20-M-09	27	1
40702	2T125MX20-M-09	25	1
40704	2T125MX20-M-09	26	1
40708	2T125MX20-M-09	8	1
40709	2T125MX20-M-09	14	1
40710	2T125MX20-M-09	13	1
40712	2T125MX20-M-09	10	1
40713	2T125MX20-M-09	23	1
43038	2T125MX20-M-06	16	1



**2T125MX22-M**  
**MOTORE - ENGINE**

-

43049	2T125MX20-M-06	1	1
48002	2T12520-M-07	29	1
48003	2T12520-M-07	23	1
48004	2T125MX20-M-09	28	2
48008	2T125MX20-M-06	19	1
48010	2T125MX20-M-09	19	1
48011	2T125MX20-M-09	12	2
48012	2T125MX20-M-09	16	1
48013	2T125MX20-M-09	6	3
48041	2T125MX20-M-09	32	1
49010	2T12520-M-03	17	1
49020	2T125MX22-M-05	2	2
49027	2T125MX22-M-05	3	2
49052	2T12520-M-07	32	1
49056	2T125MX22-M-04	4	1
49057	2T12520-M-07	20	5
49094	2T12520-M-03	13	1
49103	2T12520-M-08	8	1
	2T125MX22-M-05	6	1
49104	2T12520-M-08	13	1
49124	2T12522-M-02	12	1
49127	2T12520-M-07	33	1
49211	2T12520-M-07	19	1
49212	2T125MX20-M-06	2	1
49214	2T125MX20-M-06	24	1
	2T125MX20-M-09	22	1
49215	2T12520-M-08	20	1
49216	2T125MX20-M-09	5	4

49217	2T125MX20-M-09	11	1
49217.1	2T125MX20-M-09	34	1
49220	2T125MX20-M-01	19	1
49222	2T125MX20-M-09	33	1
49300	2T12520-M-08	7	1
49301	2T125MX22-M-05	7	1
49355	2T125MX20-M-01	27	3
49358	2T125MX20-M-01	5	6
49368	2T125MX20-M-06	14	1
49399	2T125MX20-M-01	10	1
49405	2T125MX20-M-06	31	2
49472	2T12522-M-02	3	1
49476	2T12520-M-08	10	12
49477	2T12520-M-08	11	1
	2T125MX22-M-04	7	4
49478	2T12522-M-02	18	4
49480	2T12520-M-08	12	1
49483	2T125MX20-M-06	34	2
49484	2T125MX22-M-04	3	2
	2T125MX22-M-05	14	2
	2T125MX22-M-05	15	2
49485	2T125MX20-M-06	10	1
49486	2T12520-M-07	11	2
49594	2T12520-M-08	14	1
49595	2T12520-M-08	15	3
49603	2T125MX20-M-06	26	1
	2T125MX22-M-04	2	2
49630	2T125MX20-M-01	20	1

49632	2T12522-M-02	6	2
49638	2T125MX20-M-06	25	1
49640	2T125MX20-M-01	8	4
	2T125MX22-M-05	1	4
49676	2T125MX20-M-01	35	1
49689	2T12520-M-08	22	1
49727	2T12520-M-07	30	6
49757	2T125MX20-M-01	17	1
49874	2T125MX20-M-01	22	1
49881	2T12522-M-02	13	1
49919	2T12522-M-02	17	5
49929	2T12522-M-02	7	1
49973	2T12522-M-02	15	4
50030	2T12520-M-03	14	1
50124	2T12520-M-07	12	1
51054	2T125MX22-M-05	17	2
72251	2T12522-M-02	8	2
F12301	2T12522-M-02	11	1
F12308	2T125MX20-M-01	12	1
F12321	2T12522-M-02	14	1
F19536	2T125MX20-M-01	25	1
F33314	2T125MX20-M-06	5	2