



USES AND
RACOMMENDS



www.tmracing.it

TM Racing SpA - Via Fano, 6
61122 Pesaro - ITALY
Phone: +39 0721 25113

4T250FIMX22-M

MOTORE
ENGINE

08/03/2022



INFORMAZIONI GENERALI

Il presente catalogo serve per richiedere con esattezza le parti di ricambio.

Nelle ordinazioni indicare:

1) Il numero di matricola del Telaio che è stampigliato sul lato destro del canotto di sterzo. Nei modelli EN, SMR, SMR il numero di matricola è riportato anche su una targhetta posta sul lato sinistro (Vedi foto).

2) il numero di serie del Motore. E' posto sulla sinistra del motore tra la leva cambio e i coperchio accensione (Vedi foto).

3) Il codice dei particolari seguito dalla descrizione.

4) Il colore per i pezzi verniciati o comunque colorati.

Le indicazioni destra e sinistra si riferiscono ai lati del veicolo rispetto al senso di marcia.

Foto e disegni sono solo a scopo informativo e potrebbero non corrispondere esattamente alle caratteristiche dei prodotti.

GENERAL INFORMATION

The present spare parts catalogue enables one to order exactly the right spare part.

When ordering specify:

1) The frame serial number. It is embossed on the right side of the steering metal tube. In the EN, SMR and SMR models, the serial number is also stated on a plate positioned on the left hand side (See photo).

2) The engine serial numer. It is located on the left side of the engine between the gear lever and the ignition cover (See photo).

3) The part's code number followed but its description.

4) Indicate colour for painted or colored parts.

References to right and left apply to the vehicle in terms of its direction of movement.

Photos and drawings are for informational purposes only and may not exactly match the characteristics of the products.

NOTE – LEGENDA

MY

NOVITA' INTRODOTTA DIFFERENTE O NON PRESENTE NEL MODELLO DELL'ANNO PRECEDENTE

PART DIFFERENT OR NOT PRESENT IN THE REVIOUS YEAR MODEL

5M

MOTORE CON CAMBIO A 5 MARCE
ENGINE WITH 5 GEARS SPEED

6M

MOTORE CON CAMBIO A 6 MARCE
ENGINE WITH 6 GEARS SPEED

KS

MOTORE CON SOLO KICK STARTER
ENGINE WITH KICK STARTER ONLY

ES

MOTORE CON AVVIAMENTO ELETTRICO
ENGINE WITH ELECTRIC STARTER

X

RICAMBIO NON DISPONIBILE ALLA VENDITA
PART CAN NOT BE SOLD SEPARATELY

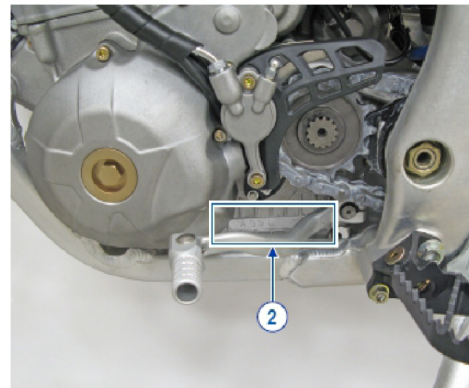
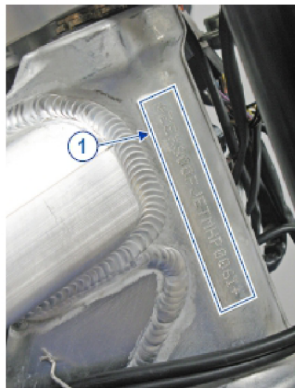

Le illustrazioni riportate in questo manuale sono fornite solo come riferimento e possono variare dal prodotto effettivo,

Dati indicativi soggetti a modifiche senza impegno di preavviso.

The illustrations in this manual are for reference only and may vary from the actual product.

All data are subject to modification without prior notice.



4T250FIMX22-M
MOTORE - ENGINE

CILINDRO PISTONE - CYLINDER AND PISTON.....	4
TESTA - HEAD.....	6
MANOVELLISMO - CRANKSHAFT.....	9
DISTRIBUZIONE - VALVES COVER.....	11
LUBRIFICAZIONE - LUBRIFICATION.....	14
CARTER MOTORE - CLUTCH CASE.....	17
FRIZIONE - CLUTCH.....	19
COMANDO CAMBIO - GEARSHIFT MECHANISM.....	22
CAMBIO 6M - GEAR BOX.....	25
ACCENSIONE ES - IGNITION ES.....	28
-	31



4T250FIMX22-M
MOTORE - ENGINE

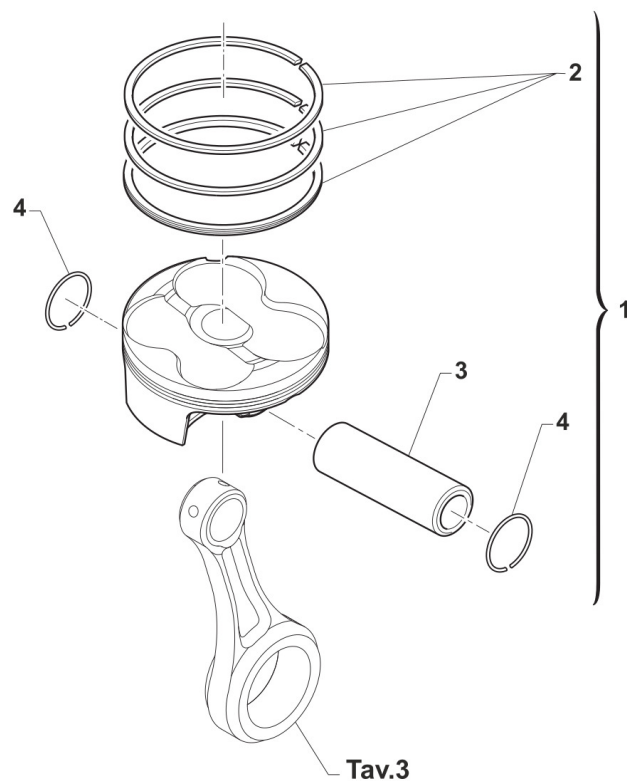

CILINDRO PISTONE
CYLINDER AND PISTON

1

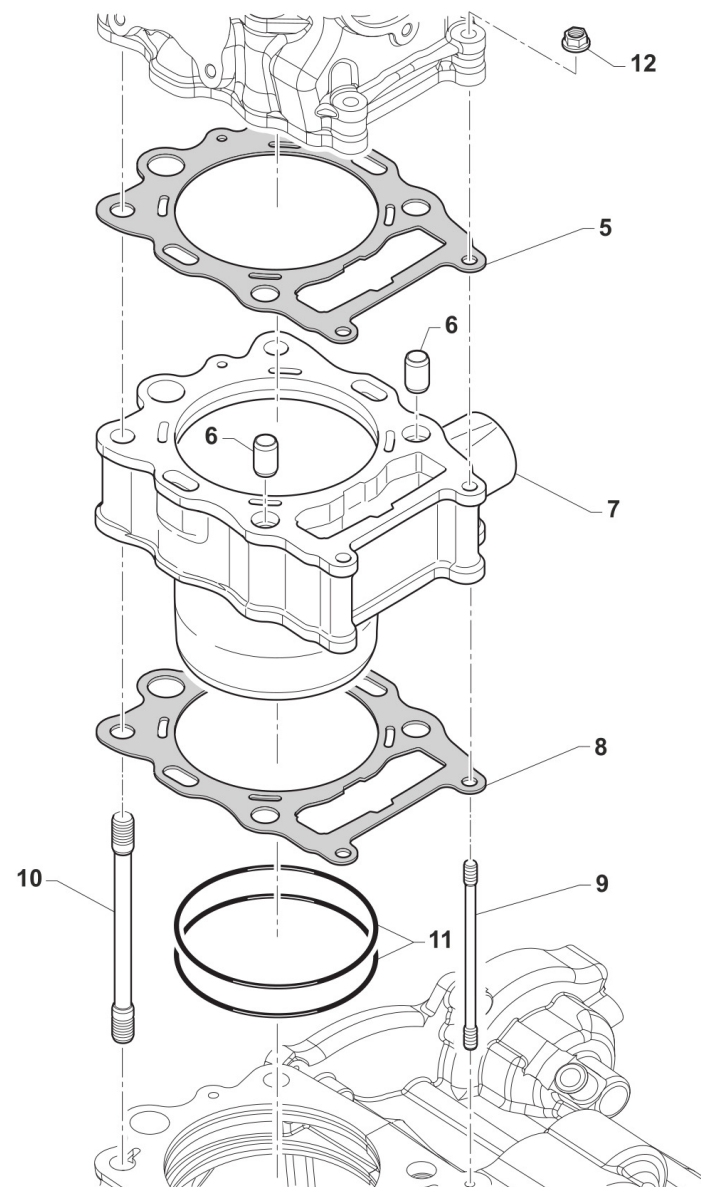

TM0001



4T250FIMX22-M
MOTORE - ENGINE

CILINDRO PISTONE
CYLINDER AND PISTON

1

1	F10879.95	1	PISTONE 250Fi MX 76,95 CPL MY 22	
1	F10879.96	1	PISTONE 250Fi MX 76,96 CPL MY 22	
1	F10879.97	1	PISTONE 250Fi MX 76,97 CPL MY 22	
2	F11384	1	KIT SEGMENTI D.77 NPR	RINGS KIT D. 77mm NPR
3	F09396.2	1	SPINOTTO 16X10.5X36 BIC.DLC S2	PISTON PIN 16X10.5X36 DLC
4	F09385	2	ANELLINO D.16X1 VP	CIRCLIP D. 16X1 VP
5	F05862.1	1	GUARNIZIONE TESTA 250Fi TWIN D. 78	HEAD GASKET D. 77 3 LAYERS CH
6	F26428	2	GRANO RIFERIMENTO 12X13 F10.2	GRUB SCREW 12X13 H.10,2mm
7	F01731	1	CILINDRO 4T 250 TWIN MX Ø77 H=34,1 MM	
8	F05856.1	1	GUARNIZ.CIL/BAS SP.0,2 EVO3 M3	GASKET CYL. TH.0,2 EVO3 M3
8	F05856.2	1	GUARNIZ.CIL/BAS SP.0,3 EVO3 M3	GASKET CYL. TH.0,3 EVO3 M3
8	F05856.3	1	GUARNIZ.CIL/BAS SP.0,4 EVO3 M3	GASKET CYL TH.0,4 EVO3 M3
8	F05856.4	1	GUARNIZ.CIL/BAS SP.0,5 EVO3 M3	GASKET CYL. TH.0,5 EVO3 M3
9	F49875	2	PRIGIONIERO M6X1 /=83 MM A10.9	STUD M 6X1 83MM
10	F49045	4	PRIGIONIERO M10X1,25 L=142,5	STUD M 10X1,25 142,5 MM
11	F12380.1	2	O RING ORM 89,0X2,0 VITON	O-RING 89 X 2
12	49676	2	DADO M 6X1 FLANG. AUTOBL.ACC.	NUT, FLANGED M6 X 1 S.B.

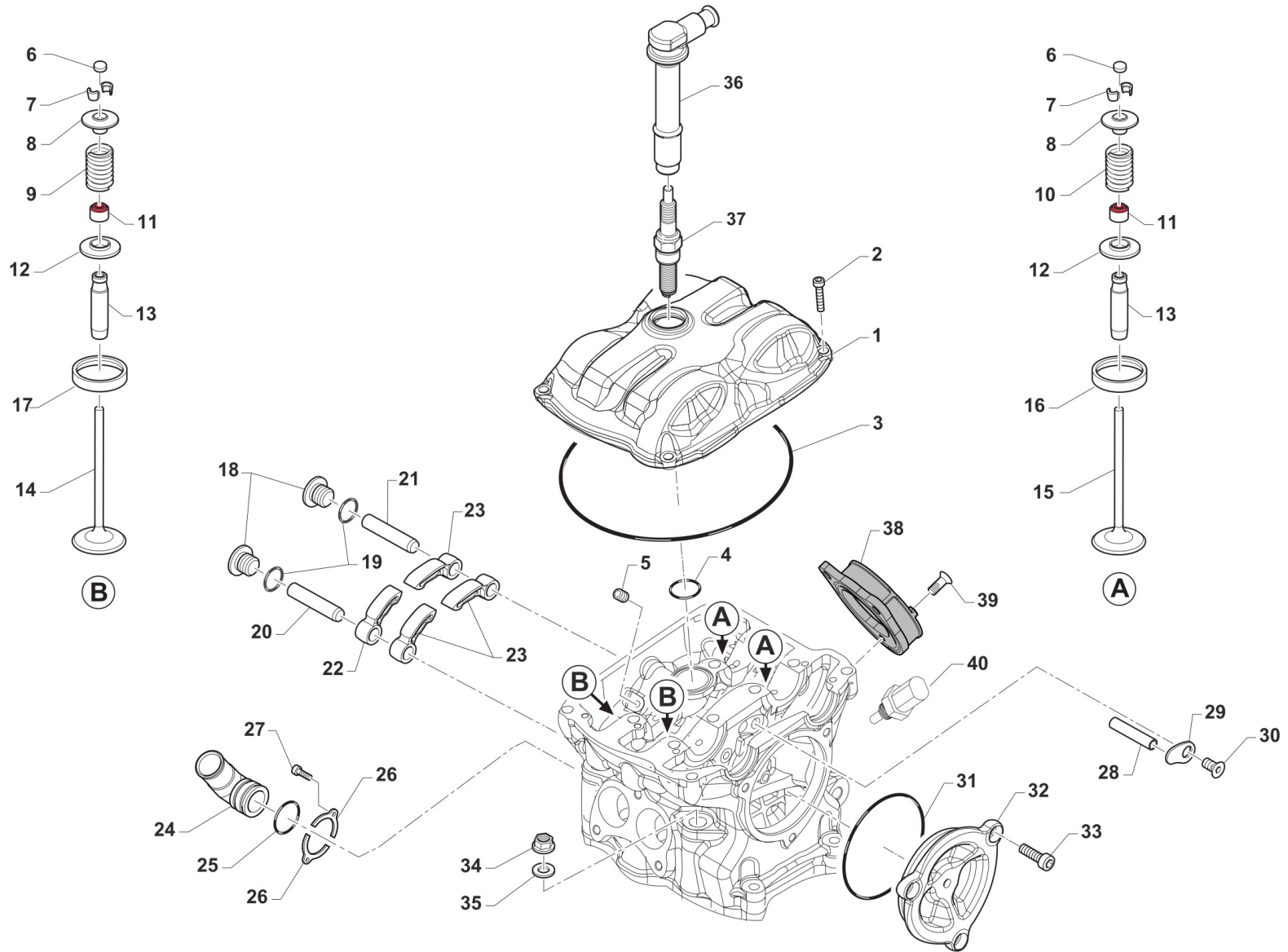

0002.02



4T250FIMX22-M
MOTORE - ENGINE

TESTA
HEAD

1	F30061	1	COPERCHIO TESTA 250Fi MX MY18	CYLINDER HEAD COVER 250Fi F.S. MX M18->
2	49482	4	VITE TCEI 6X14 UNI 5931	BOLT TCEI 6X14
3	F12364	1	O RING 155X2	O-RING 155 X 2
4	F12345.1	1	O RING ORM 24,0X1,5 VITON	O-RING 24 X 1,5
5	49702	1	GRANO 5X 6 VALV.SC.MARTELLETTO	GRUB SCREW 5 X 6 INLET VALVE
6	F26603.255	1	PASTIGLIA REGOLAZ. GIOCO Ø 7,26 Sp. 2,55	SHIM, VALVE ADJUSTING Ø 7,26 TH. 2,55
6	F26603.260	1	PASTIGLIA REGOLAZ. GIOCO Ø 7,26 Sp. 2,60	SHIM, VALVE ADJUSTING Ø 7,26 TH. 2,60
6	F26603.265	1	PASTIGLIA REGOLAZ. GIOCO Ø 7,26 Sp. 2,65	SHIM, VALVE ADJUSTING Ø 7,26 TH. 2,65
6	F26603.270	1	PASTIGLIA REGOLAZ. GIOCO Ø 7,26 Sp. 2,70	SHIM, VALVE ADJUSTING Ø 7,26 TH. 2,70
6	F26603.275	1	PASTIGLIA REGOLAZ. GIOCO Ø 7,26 Sp. 2,75	SHIM, VALVE ADJUSTING Ø 7,26 TH. 2,75
6	F26603.280	1	PASTIGLIA REGOLAZ. GIOCO Ø 7,26 Sp. 2,80	SHIM, VALVE ADJUSTING Ø 7,26 TH. 2,80
6	F26603.285	1	PASTIGLIA REGOLAZ. GIOCO Ø 7,26 Sp. 2,85	SHIM, VALVE ADJUSTING Ø 7,26 TH. 2,85
6	F26603.290	1	PASTIGLIA REGOLAZ. GIOCO Ø 7,26 Sp. 2,90	SHIM, VALVE ADJUSTING Ø 7,26 TH. 2,90
6	F26603.295	1	PASTIGLIA REGOLAZ.GIOCO Ø 7,26 Sp. 2,95	SHIM, VALVE ADJUSTING Ø 7,26 TH. 2,95
6	F26603.300	1	PASTIGLIA REGOLAZ. GIOCO Ø 7,26 Sp. 3,00	SHIM, VALVE ADJUSTING Ø 7,26 TH. 3,00
6	F26603.305	1	PASTIGLIA REGOLAZ. GIOCO Ø 7,26 Sp. 3,05	SHIM, VALVE ADJUSTING Ø 7,26 TH. 3,05
6	F26603.310	1	PASTIGLIA REGOLAZ. GIOCO Ø 7,26 Sp. 3,10	SHIM, VALVE ADJUSTING Ø 7,26 TH. 3,10
6	F26603.315	1	PASTIGLIA REGOLAZ. GIOCO Ø 7,26 Sp. 3,15	SHIM, VALVE ADJUSTING 7,26 TH. 3,15
6	F26603.320	1	PASTIGLIA REGOLAZ. GIOCO Ø 7,26 Sp. 3,20	SHIM, VALVE ADJUSTING 7,26 TH. 3,20
7	F14178	8	SEMICONO D.5 - 15^ HAYFIELD	VALVE RETAINER D.5 15^HAYFIELD
8	F26597	4	PIATTELLO SUP. MOLLA 250M3	UPPER PLATE
9	F16473	2	SET MOLLA EST. + MOLLA INT. SCAR.	EXTER. & INTER.SPRINGS EXHAUST
10	F16472	2	SET MOLLA EST. + MOLLA INT. ASP.	EXTER. & INTER.SPRINGS INLET
11	F04388	4	ANELLO TENUTA STELO VALV.D.5mm SKF	
12	F26689	4	PIATTELLO T 24X4	LOWER PLATE
13	F26728	4	GUIDA VALVOLA SINT. D.5 PER TENUTA SKF	
14	F14158	2	VALVOLA SCA 250Fi 26.8x5 TIT	EXHAUST VALVE 250Fi TIT 26.8X5
15	F14164	2	VALVOLA ASP 250Fi 32x5 TIT	INLET VALVE d.35X5 250Fi TIT



4T250FIMX22-M
MOTORE - ENGINE

TESTA
HEAD

16	F26557	2	SEDE VALVOLA ASP.250cc	
17	F26558	2	SEDE VALVOLA SCAR.250cc	
18	F49871	2	TAPPO ASSE ROT.BILANC.250 M3	PLUG
19	F12325	2	OR ORM 090-15 FILTRO ASP.OLIO 250N	O-RING
20	F28812	1	ASSE ROTAZIONE BIL.SCAR. 250M3	AXLE, ROCKER ARM EXHAUST
21	F28811	1	ASSE ROTAZIONE BIL.ASP.250M3LO	AXLE, ROCKER ARM INTAKE
22	F28836	1	FINGER FOLLOWER WITH DECOM.MIM	FINGER FOLLOWER WITH DECOM.MIM
23	F28835	3	FINGER FOLLOWER NO DECOMP. MIM	FINGER FOLLOWER NO DECOMP. MIM
24	F28841	1	RACCORDO USCITA ACQUA TESTA	JOINT, HEAD WATER
25	F12346.1	1	O RING ORM 18,0X2,0 VITON	O-RING 18 X 2
26	F48374	2	PIASTRINO RITEGNO RACCORDO H2O	PLATE
27	49553	2	VITE TCEI 4X8	BOLT TCEI 4X8
28	F28810	1	ASSE ROTAZIONE BIL.ASP.250M3LC	AXLE, ROCKER ARM INTAKE
29	F48371	1	PIASTRINO BATT.ASSE ROT.BIL.LC	PLATE
30	49396	1	VITE TSEI 5X10	BOLT TSEI 5X10
31	F12351.1	1	O RING ORM 61,6X2,4 VITON	O-RING 61,6 X 2,4
32	F30015	1	COPERCHIO ISP. TESTA 250Fi 250 REP.4T	COVER, HEAD, TWIN
33	49481	3	VITE TCEI 6X12	BOLT TCEI 6X12
34	F49874	4	DADO M 10 X 1,25 CH 12 FLANGIATO	NUT FLANGED M 10x1,25 T.12mm
35	F48400	4	RONDELLA Ø10xØ17,5x3	WASHER Ø10xØ17,5x3
36	F21436	1	PIPETTA CANDELA RESISTIVA 250 4T MY18->	CAP, SPARK PLUG
37	F06116	1	CANDELA NGK R0451B-8	SPARK PLUG NGK R0451B-8
38	F13287	1	COLLETTORE ASPIRAZIONE 250Fi 4T REPL.	INLET MANIFOLD 250Fi F.S. R.
39	49989	3	VITE TS 5X14 TORX	BOLT TORX 5 X 14
40	F08003	1	SENSORE TEMP. ACQUA WTS 09/02	SENSOR, WATER TEMPERATURE



4T250FIMX22-M
MOTORE - ENGINE

MANOVELLISMO
CRANKSHAFT

3

1	F18134	1	E.S.	ALBERO MOTORE 4T 250 MX ES MY 22 CPL	
2	F18134.1	1	E.S.	COPPIA SEMIALBERI 4T 250 MX ES MY 22	
3	F18111	1		BIELLA 250Fi MX 4T 2018 CPL	CONROD ASSY 250Fi MX 4S M.18->
4	F03375.4	1		BRONZINA CP BIELLA 30X34X18 BB BLU/BLU	CONNECTING ROD BUSH ASSY 30x34x18 blu
4	F03375.5	1		BRONZINA CP BIELLA 30X34X18 RG ROSSO/GIALLO	BUSH ASSY 30x34x18 RED/YELLOW
5	F18059	1		ASSE ACCOPP. D.30X54,7 X BRONZ	
6	F18093	1		BIELLA D34XD.16 I.94.5 BR	
7	F49853	1		CHIAVETTA 5X3X25 UNI7510R.F.A.	WOODRUFF KEY, 5x3x25
8	03026	2		CUSCINETTO ALBERO MOTORE NJ206	BUSH, NJ206 CRANKSHAFT
9	F04375	1		PARAOLIO 25X35X4	
10	F32573	1		UGELLO RAFFREDDAMENTO	NOZZLE
11	49472	1		VITE TCEI 5X12 UNI 5931	BOLT TCEI 5X12
12	F40057	1		PIGNONE TRASM.PRIMARIA Z17 SCANAL.	
12	F40057.1	1		PIGNONE TRASM.PRIM.Z17 SC.PROV	
12	F40057.3	1		PIGNONE TRASM.PRIM.Z17	
13	49255	1		SEEGER RETTIFICATO CAMBIO 250	CIRCLIP, GEAR BOX 250cc

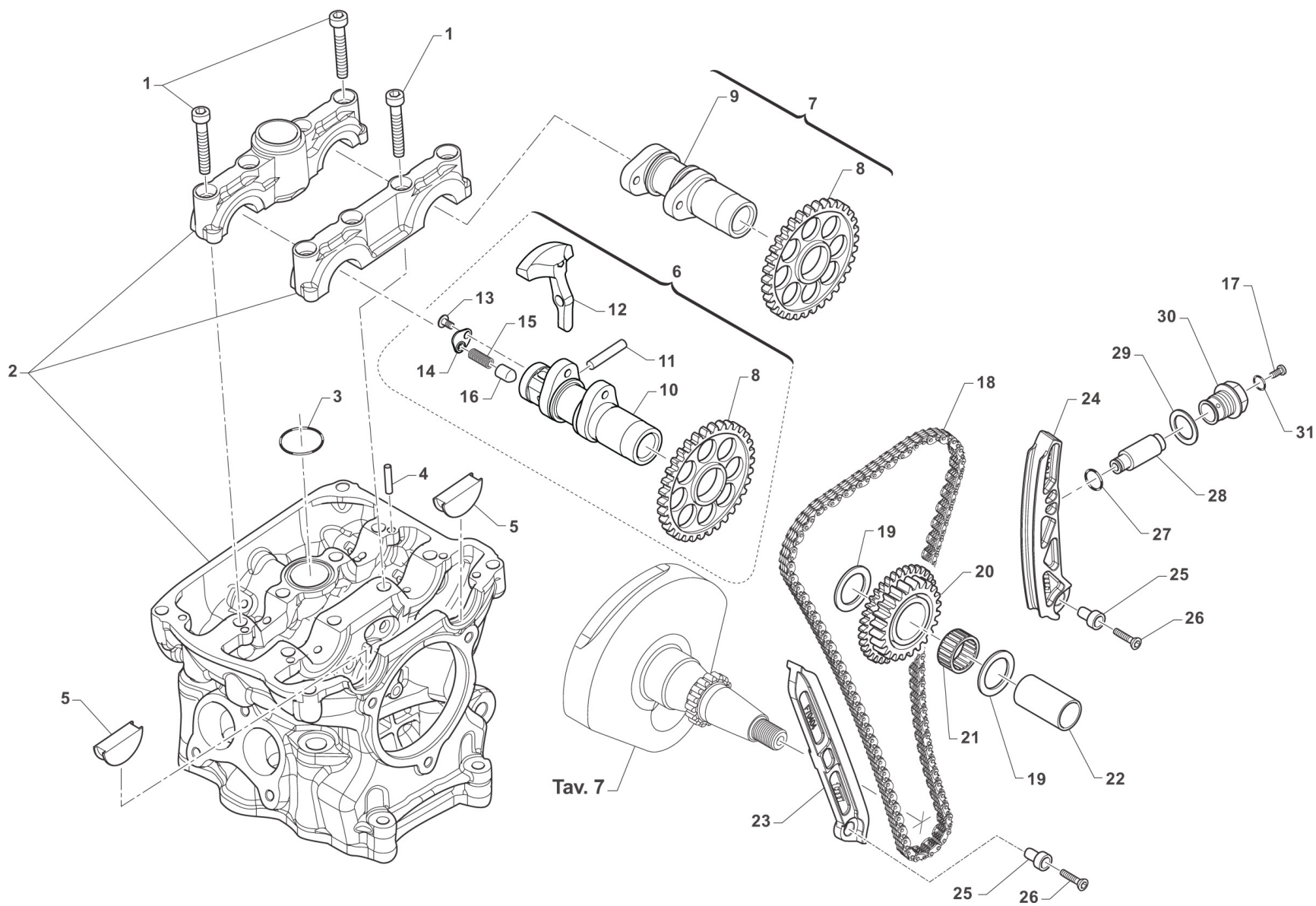

M0004T



4T250FIMX22-M
MOTORE - ENGINE

DISTRIBUZIONE
VALVES COVER

4

1	49487	8		VITE TCEI 6X35 UNI 5931	BOLT TCEI 6X35
3	F12344.1	1		O RING ORM 23,0X1,5 VITON	O-RING 23 X 1,5
4	F19529	4		RULLO D.4 X 10 TESTA BOMBATA" NRA"	PIN 4 X 10
5	F30060	2		COPERC.TTO FORI A.CAMME250/300	CAP, HOLE CAMSHAFT 250/300
6	F28852	1	E.S.	ALBERO A CAMME SCARICO 250Fi MX ES + EN CPL	CAMSHAFT ASSY, EX, 250 MX ES + EN
7	F28873	1		ALBERO A CAMME ASP CPL XA-16	
8	F40062	2		INGR. ALBERO A CAMME GEN. Z28	GEAR 28T, CAMSHAFT
9	F28869	1		ALBERO A CAMME XA-16	
10	F28809	1		ALBERO A CAMME SCAR.EVO3 XS-04	CAMSHAFT EX XS-04
11	F19530	1		RULLO D.5 X 19.8 G2 0 -0.010	PIN 5 X 19,8
12	F26575	1		DECOMPRESSORE (MASSA CENT.) M3	DECOMPRESSOR
13	49597	1		VITE TBCEI 4 x 8 UNI 7380	BOLT TBCE 4 x 8
14	F48368	1		PIASTRINO GUIDA MOLLA DECOMPR.	PLATE DECOMPRESSOR SPRING 250 F.S.
15	F16479	1		MOLLA AZIONAMENTO DECOMP. D.0,3 250 4T REP.	SPRING
16	F26576	1		PISTONCINO ATTIVAZIONE DECOMP.	PISTON DECOMPRESSOR
17	F49871	1		TAPPO ASSE ROT.BILANC.250 M3	PLUG
18	F70422	1		CATENA DIST.MORSE 92RH2015 90P 250 TWIN	CAM CHAIN 82RH2015 90
19	F48372	2		RASAMENTO 18 x 30 x 0.8	SHIM 18 X 30 X 0,8
20	F40061	1		INGR. DOPPIO DISTRIBUZ.24/21	GEAR 24/21T DISTRIBUTION
21	F19526	1		GABBIA A RULLINI K 18X22X17	NEEDLE BUSH 18x22x17
22	F28813	1		ASSE ROTAZIONE INTR.18X42,7F13	PIN ROTATION GEAR 18x42,7 H.13
23	F70404	1		PATTINO FISSO 4T 250/300 TWIN	FIXED SLIDER
24	F70413	1		PATTINO MOBILE 4T 250/300 TWIN	MOVING SLIDER
25	F49883	2		BOCCOLA FISS. PATT.MOB. F70402	BUSH
26	49406	2		VITE TSEI 6X20	BOLT TSEI 6x20
27	F12346.1	1		O RING ORM 18,0X2,0 VITON	O-RING 18 X 2
28	F70408	1		TENDITORE IDRAULICO 250 M3 F-346264.89-0100.KSH.KSYS	HYDRAULIC TENSIONER 250Fi M3
29	49949	1		RONDELLA RAME 24X30X1,5	WASHER, COPPER, 24 X 30 X 1,5



4T250FIMX22-M
MOTORE - ENGINE

DISTRIBUZIONE
VALVES COVER

30	F49884	1	TAPPO TENSIONATORE IDR. M3	PLUG, TENSIONER
31	F12356.1	1	O RING ORM 10,0X1,0 VITON	O-RING 10 X 1

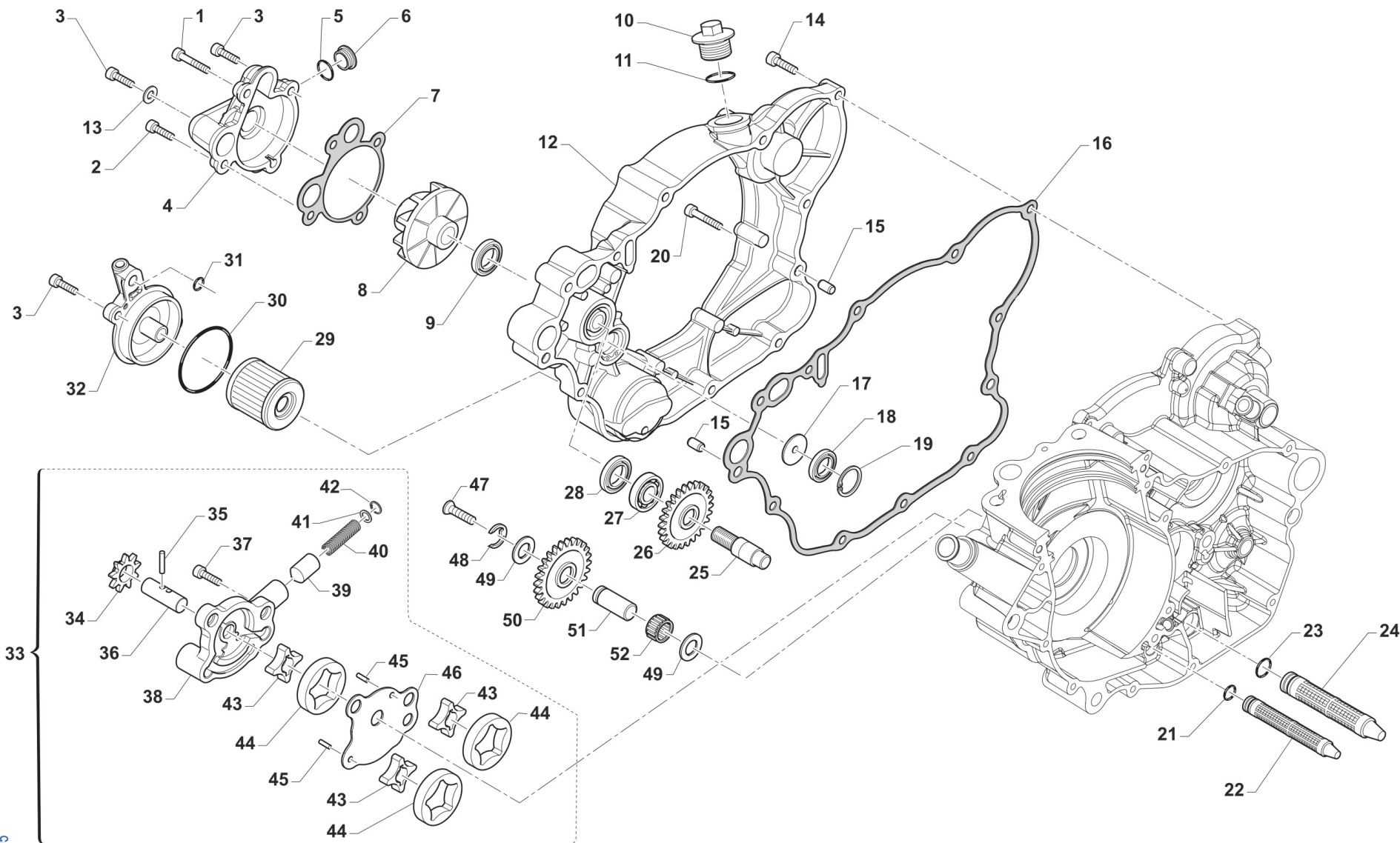

TM0005



4T250FIMX22-M
MOTORE - ENGINE

LUBRIFICAZIONE
LUBRIFICATION

1	49575	1	VITE TCEI 5X45 UNI 5931	BOLT TCEI 5X45
2	49570	1	VITE TCEI 5X50 UNI 5931	SCREW TCEI 5X50
3	49476	3	VITE TCEI 5X20 UNI 5931	BOLT TCEI 5X20
4	F30966	1	COPERCHIO POMPA H2O 250Fi 11/-	COVER, WATER PUMP 250Fi M.2011
5	F12327	1	O RING COPERCHIO P.ACQUA 250N	O-RING COVER WATER PUMP 250 4S
6	F49841	1	TAPPO COP. POMPA H2O 250Fi	CAP, COVER WATER PUMP 250 4S
7	F05833	1	GUARNIZ.COP.POMPA ACQUA.250N	GASKET, H2O COVER 250Fi
8	F28679	1	GIRANTE POMPA ACQUA 250N	IMPELLER, H2O PUMP 250Fi
9	04017	1	PARAOLIO CENTRIFUGA 06 +MF1TAG	OIL SEAL 8 X 22 X 7 TC
10	F49925	1	TAPPO CARICO OLIO M20X1.5	OIL PLUG M20X1,5
11	F49920	1	RONDELLA ALL 20.4X26X1.5	WASHER 20,4X26X1,5 ALUM.
12	F30961	1	COPERCHIO TRAS. PRIM. 250N '11	COVER, PRIMARY DRIVE 250N 11->
13	49119	1	RONDELLA 5 x 9 x 1,5 ALLUMINIO	WASHER, 5 x 9 x 1.5 ALLUMINIUM
14	49477	7	VITE TCEI 5X25 UNI 5931	BOLT TCEI 5X25
15	26041	2	GRANO CENTRAGGIO D.7X8 F.5,2	DOWEL PIN 7 x 8 Hole 5,2
16	F05828	1	GUARNIZ.COP.TRASM.PRIMAR.250N	GASKET, CLUTCH CASE 250Fi
17	F32529	1	DISCHETTO PARZIAL. MAND.OLIO 250N	DISC OIL PUMP 250 F.S.
18	F04390	1	PARAOLIO FAJ 14-22-5 HS	OIL SEAL FAJ 14-22-5 HS
19	F49913	1	SEEGER I 23	CIRCLIP INT. 23
20	49478	1	VITE TCEI 5X30 UNI 5931	BOLT TCEI 5X30
21	F12325	1	OR ORM 090-15 FILTRO ASP.OLIO 250N	O-RING
22	F32532	1	FILTRO ASPIRAZ.POMPE OLIO 250N	FILTER, OIL, 250Fi
23	F12343	1	O RING FILTRO OLIO 250F	O-RING
24	F32555	1	FILTRO ASPIRAZIONE OLIO MAGG.	FILTER OIL INLET
25	F28658	1	ALBERINO POMPA H2O 250N	SHAFT, WATER PUMP 250Fi
26	F40955	1	INGRAN. POMPA ACQUA Z20 250N	
27	F03365	1	CUSCINETTO POMPA ACQUA 250/09	BEARING WATER PUMP 250/09
28	F04363	1	PARAOLIO 8X22X5 250/09->	OIL SEAL 8x22x5 (250F/09)



4T250FIMX22-M
MOTORE - ENGINE

LUBRIFICAZIONE
LUBRIFICATION

29	F66510	1	FILTRO OLIO 4Tempi HF 141	OIL FILTER HF - 141
30	12094	1	O RING COP. FILTRO OLIO	O RING OIL FILTER COVER
31	F12302	1	O RING 108 PIOGGIA CAMBIO 4T	O-RING, 108 GEAR F.S.
32	F30965	1	COPERCHIO FILTRO OLIO 250Fi 11	CAP, OIL FILTER 250Fi 11->
33	F30068	1	POMPA OLIO COMPLETA 250/300 Fi TWIN	OIL PUMP ASSY
34	F40997	1	INGRANAGGIO POMPA OLIO 250Fi Z 9	GEAR, OIL PUMP 250Fi 9 T
35	F19513	3	RULLINO ING. POMPA 250/09	PIN, PUMP GEAR 250 09->
36	F28840	1	ALBERINO POM.OLIO RO.H10/2XH10	SHAFT, OIL PUMP
37	49751	2	VITE TCEI 5X22	BOLT TCEI 5 X 22
38	F30059	1	CORPO POMPA	OIL PUMP BODY
39	F32533	1	PIST.NE VALV.LIMIT.PRESS.OLIO	PISTON
40	F16441	1	MOLLA VALVOLA PRESS.OLIO 250N	SPRING
41	49600	1	RONDELLA 4x8x0,8	WASHER 4
42	49267	1	SEEGER 8mm INT Sp. 0,8	SEEGER
43	F32577	3	ROTORE INTERNO POMPA OLIO 250Fi	ROTOR, OIL PUMP, INTERNAL
44	F32578	3	ROTORE ESTERNO POMPA OLIO 250Fi	ROTOR, OIL PUMP, EXTERNAL
45	F19521	2	RULLINO D.3 X 11	PIN 3 X 11
46	F32574	1	SEPARATORE POMPA OLIO	PLATE
47	49429	1	VITE TSEI 4X35	BOLT TSEI 4X35
48	F49821	1	SEEGER ING. FOLLE P.OLIO 250/09	SEEGER INTER.GEAR OIL P.250 4S
49	F19512	2	RALLA ING.FOLLE P. OLIO 250/09	THRUST WASHER
50	F40909	1	INGR. OZIOSO POMPA OLIO 250N	GEAR, OIL PUMP
51	F28665	1	ALBERINO ING.FOLLE P.OLIO 250N	SHAFT
52	F19511	1	GABBIA RULLI ING.F.P.OL.250/09	NEEDLE CAGE GEAR 250F 09->

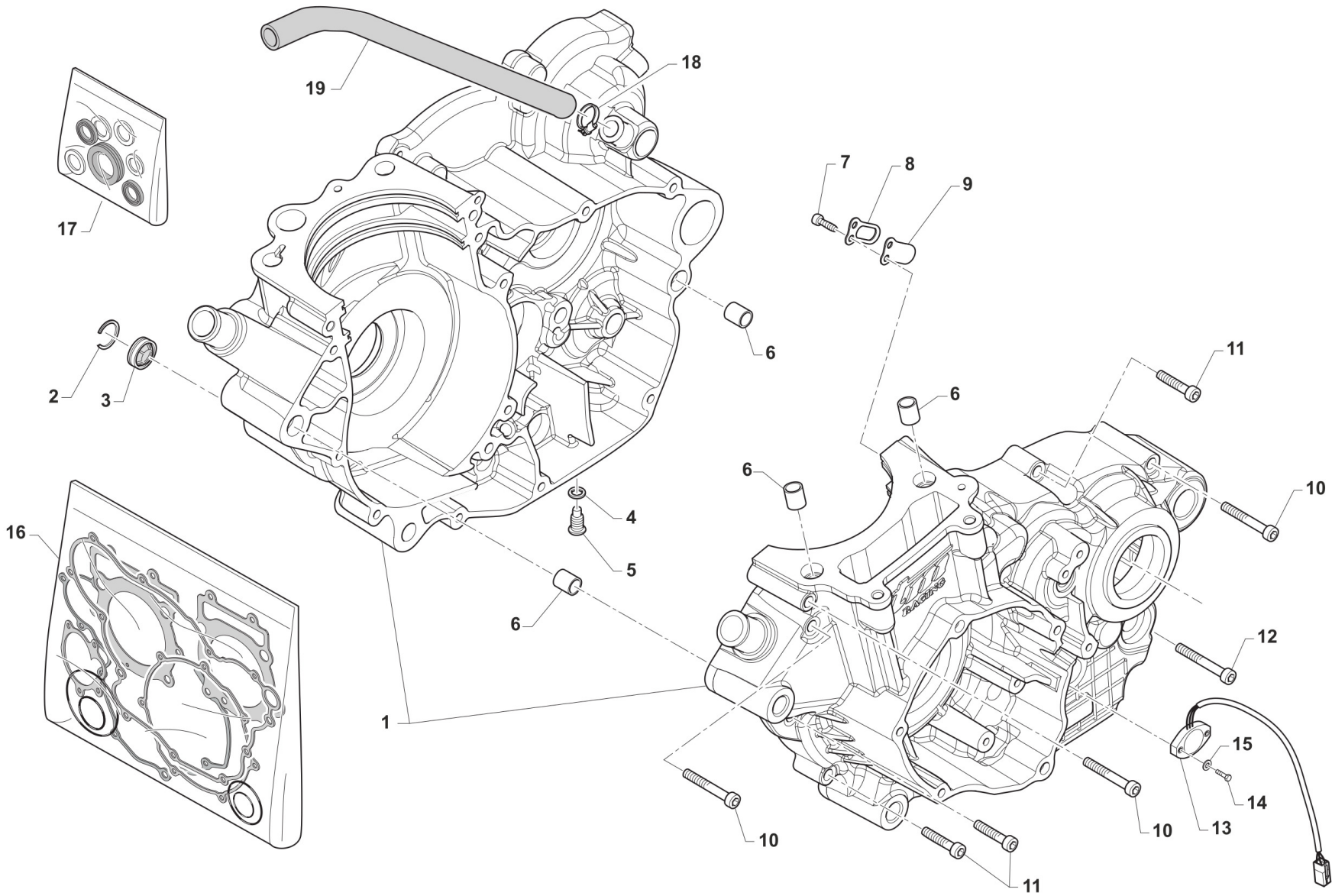

TM 0006.01



4T250FIMX22-M
MOTORE - ENGINE

CARTER MOTORE
CLUTCH CASE

1	F30070	1	BASAMENTO MOTORE 250Fi ES	CRANKCASE, 250Fi 4S ES
2	F49832	1	SEEGER SB25 OBLO' 250Fi 10/->	SEEGER
3	F04366	1	OBLO' LIVELLO OLIO DIAM.25 MM	OIL LEVEL INSPECTION SIGHT GLASS
4	49125	2	RONDELLA 12X18X1,5 ALLUMINIO	WASHER 12X18X1,5 Al
5	F49820.1	2	TAPPO OLIO C/CALAM. 250Fi	OIL PLUG WITH MAGNET 250Fi
6	F26428	4	GRANO RIFERIMENTO 12X13 F10.2	GRUB SCREW 12X13 H.10,2mm
7	49542	1	VITE TCEI 5X10 UNI 5931	BOLT TCEI 5 X 10
8	F20004	1	STOPPER LAMELL.CAMERA ALB.250N	STOPPER, STOP
9	F20003	1	LAMELLA SFIATO PRESS.250Fi	REED
10	49491	3	VITE TCEI 6X55	BOLT TCEI 6X55
11	49487	4	VITE TCEI 6X35 UNI 5931	BOLT TCEI 6X35
12	49492	1	VITE TCEI 6X60	BOLT TCEI 6X60
13	F08456	1	SENSORE POSIZIONE CAMBIO eM060 CPL G.ORARIO (SOSTITUISCE F08236.1)	
14	49922	2	VITE TE 3X14	
15	49926	2	RONDELLA 3X9X1	WASHER 3 X 9 X 1
16	F05863	1	KIT GUARNIZIONI 250Fi MX 18/21 EN 19/21 TWIN	GASKET KIT 250Fi MX 18/21 EN 19/21 TWIN
17	04043	1	KIT PARAOLI 4T 250/300Fi TWIN MY2022	
18	51073	1	FASCETTA 10/19	CLAMP 10 / 19 mm
19	F65104	1	TUBO COPOLAN GRIGIO 11x16	HOSE COPOLAN GREY 11X16mm

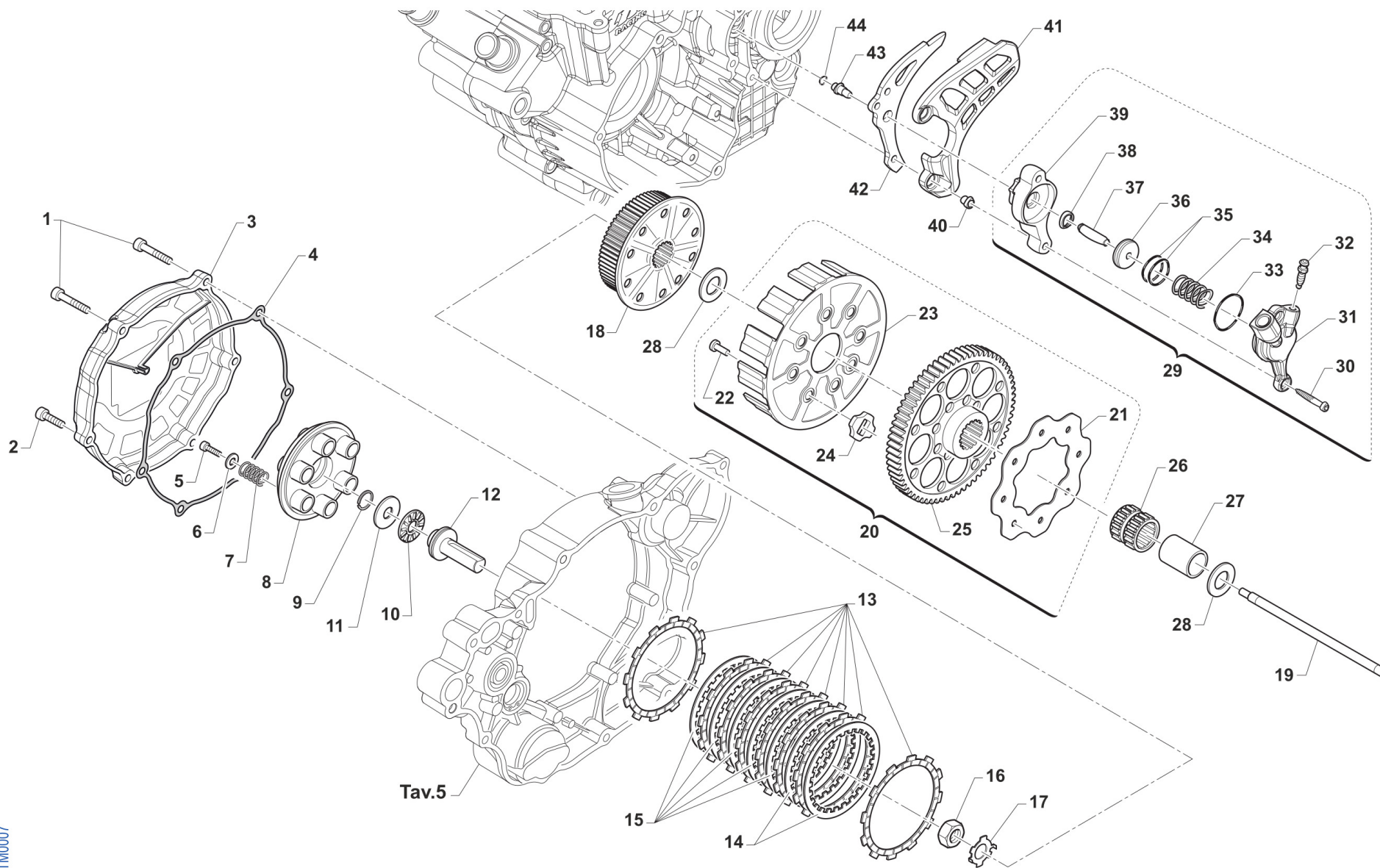



4T250FIMX22-M
MOTORE - ENGINE

FRIZIONE
CLUTCH

1	49736	2	VITE TCEI 5X65	BOLT TCEI 5X65
2	49477	4	VITE TCEI 5X25 UNI 5931	BOLT TCEI 5X25
3	F30960	1	COPERCHIETTO FRIZ.250Fi M.11->	COVER, CLUTCH 250Fi M. 11/->
4	F05841	1	GUARN. COP. FRIZ. 250Fi 2011	GASKET, CLUTCH COV 250Fi 11/->
5	49484	6	VITE TCEI 6X20	BOLT TCEI 6X20
6	49604	6	RONDELLA 6 X18 X 1,6	WASHER 6x18
7	F16453	6	MOLLA FRIZIONE 2/4T 250/450	SPRING, CLUTCH 2/4T 250/450
8	F25258	1	PIATTO SPINGIDISCHI 250Fi	PRESSURE PLATE, CLUTCH 250Fi
9	09006	1	ANELLINO FERMA SPINOTTO 80/85/100	CLIP, PISTON PIN 80/85/100cc
10	19022	1	GABBIA A RULLI RAD. AXK 1528	BUSH CAGE AXK 1528, RADIAL
11	19023	1	RONDELLA GABBIA RULLI AS 1528	WASHER, NEEDLE CAGE AS 1528
12	F35582	1	FUNGO FRIZIONE IDRAULICA 2015	PIECE, CLUTCH LIFTER
13	F35588	8	DISCO FRIZIONE 250Fi 4T FCC	CLUTCH PLATE, FIBER 250Fi 4S
14	F35596	2	DISCO FRIZ. ACC 1,8 mm 250Fi	CLUTCH DISC STEEL 1,8 mm 250Fi
15	F35541	5	DISCO FRIZ. ACC 1,5 mm 250N	CLUTCH PLATE, STEEL 1,5 250Fi
16	49060	1	DADO TAMBUR.FRIZ. ALB.PRIM. 250/300 M18X1.5	NUT, CLUTCH CENTER 250cc
17	35050	1	RONDELLA X FRIZ. 250/300/4T	CLUCTH WASHER 250/300/F
18	F25256	1	TAMBURELLO FRIZ.250F -N-	CLUTCH CENTER 250Fi
19	F35544	1	ASTINA CENTRAL.FRIZ.192mm 250N	ROD, CLUTCH 192mm 250N
20	F40038	1	COPPIA PRIMARIA CPL 250Fi z60	
21	35262	1	DISCO BATTUTA GOMMINI FRIZ. 2T/4T F.6 MM	PLATE, CLUTCH BASKET 250cc
22	49202	8	CHiodo FRIZIONE K3/KV/K7 D 5,8	PIN CLUTCH K3/KV/K7/K8/K9
23	F25257	1	CAMPANA FRIZ. 250Fi	CLUTCH BASKET 250Fi M. 10/->
24	21005	8	GOMMINO PARASTRAPPI FRIZIONE	RUBBER, CLUTCH BASKET
25	F40954	1	COPPIA PRIMARIA Z60/18 250N	
26	F19510	1	GABBIA A RULLINI K 27X32X23.8	NEEDLE CAGE 27 x 32 x 23.8
27	F26422	1	BOCCOLA INGR.TRASM.PRIM. 250N	BUSH, PRIMARY GEAR 250Fi
28	48250	2	SPESSORE COPPIA PRIMARIA 250	SPACER, PRIMARY GEAR 250cc



4T250FIMX22-M
MOTORE - ENGINE

FRIZIONE
CLUTCH

29	F30005	1	COP. FRIZ/IDR 4T 250N D.26 CPL	COVER, IDR/CLUTCH 4S 250N ASSY
30	49535	2	VITE TCEI 5X35 UNI 5931	BOLT TCEI 5X35
31	F30006	1	CORPO CILIN. FRIZ. 250Fi D.26	BODY CLUTCH CYLINDER 250Fi D26
32	35264	1	VITE SPURGO OLIO FRIZ.IDR.6X1	SCREW AIR BLED HYDRAUL.CLUTCH
33	12252	1	O RING PIGNONE CAT.+DIS.AL.MOT	O-RING, 25,12 x 1,78
34	F16445	1	MOLLA PIST. FRIZ. 250N CONICA	SPRING
35	12259	2	O RING PISTONE FR.125/250VERDE	O-RING, CLUTCH PISTON 125/250
36	F35522	1	PISTONE CILINDRETTO 250N D.26	PISTON CLUTCH CYLINDER 250F 26
37	F19518	1	RULLO D.S. 5 X 24	PIN 5 X 24
38	F04367	1	PARAOLIO 9X13X3	OIL SEAL 9X13X3
39	F35523	1	DISTANZIALE CILINDRETTO 250N	SPACER CYLINDER 250N
40	26211	2	BOCCOLA PROT. PIGNONE 250 F.5	COLLAR, SPROCKET 250cc H.5
41	F30944	1	PROTEZIONE PIGNONE 250Fi PLAST	SPROCKET PROTECTION 250 F.I. PLAST.
42	F70370	1	PROTEZ. ERGAL PIGN. CAT 250N	PROTECTION, ALUMINIUM, FRONT SPROCKET
43	F26460	1	DIST.CENTR.SUPP.ATT.FRIZ.250N	SPACER
44	F12302	1	O RING 108 PIOGGIA CAMBIO 4T	O-RING, 108 GEAR F.S.

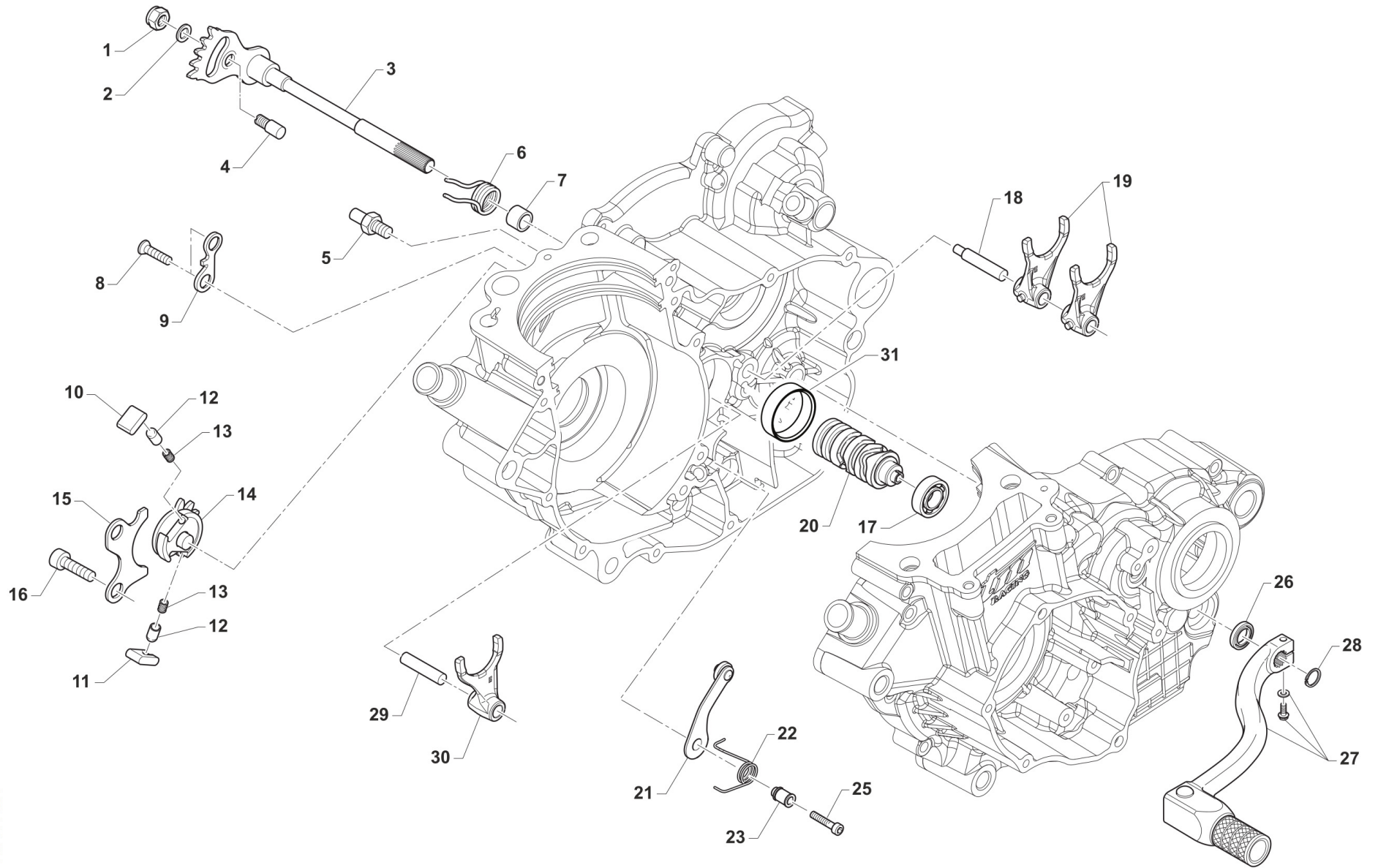

TM 0008.01



4T250FIMX22-M
MOTORE - ENGINE

COMANDO CAMBIO
GEARSHIFT MECHANISM

1	49638	1		DADO M 6 ALTO AUTOBLOCCANTE	NUT 6mm, HIGHT SELF-LOCKING
2	49603	1		RONDELLA M 6,4 X 12 X 1,6	WASHER 6x12
3	26050	1		BATTUTA ECCENTRICA	ADJUSTER SELECTOR SHAFT
4	28100	1		ALBERO COMANDO ING. P.TACRIC.	SHAFT, GEARSHIFT
5	F26455	1		BATTUTA FISSA MAN.CAMBIO 250N	
6	16010	1		MOLLA RITORNO LEVA CAMBIO 3	SPRING, RETURN GEAR LEVER 3mm
7	26006	1		DISTANZIALE MOLLA LEVA CAMBIO	SPACER, GEAR LEVER SPRING
8	49405	2		VITE TSEI 6X20 UMB.5933 10.9	BOLT TSEI 6x20 U.5933 10.9
9	F26454	1		PIASTR.FINECORSO CRIC. 250N	PLATE, ENDSTROKE RATCHET 250N
10	26060	1		CRICCHETTO CAMBIO SUPERIORE	RATCHET UP, GEAR
11	26061	1		CRICCHETTO CAMBIO INFERIORE	RATCHET DOWN, GEAR
12	26062	2		PUNTALE PER CRICCHETTO CAMBIO	PIN, RATCHET GEAR
13	16012	2		MOLLA PER PUNTALE	SPRING, GEARBOX PIN
14	40310	1		INGRANAGGIO PORTACRICCHETTI	DRUM SHIFTER GEAR
15	26021	1		PIASTRINO RIENTRO CRICCHETTI	PLATE, RATCHET
16	49483	2		VITE TCEI 6X16 UNI 5931	BOLT TCEI 6X16
17	03012	1		CUSCINETTO DESMODROMICO 6001 2RS	BUSH, 6001 2RS GEAR DRUM
18	33256	1		PERNO FORCH.ALB.SEC. 250 / 125.99	AXEL, COUNTERSHAFT FORK 250cc
19	F33312	2		FORCHETTA A/S 250Fi CROMATA	SHIFT FORK COUNTERSHAFT 250 4S
20	F33353.1	1	PER CAMBIO 6M	DESMODROMICO 250/300 4TFI 6M. PR.4	
21	26095	1		PIASTRINO BLOCCAMARCE KV/95CPL	PLATE, STOP GEAR KV/95 ASSY
22	F16447.3	1		MOLLA BLOCCA MARCE 250 4T D.FILO 2.4	
23	26007	1		DISTANZIALE MOLLA BLOCCAMARCE	SPACER, STOP GEAR SPRING
25	49485	1		VITE TCEI 6X25 UNI 5931	BOLT TCEI 6x25
26	04004	1		PARAOLIO POMPA H2O-LEVA CAMBIO	OIL SEAL 12 x 22 x 5
27	43049	1		LEVA CAMBIO 250 / 300 2T E.S. 19	GEAR LEVER 250 / 300 T.STR. EL.ST. M.19->
28	49212	1		SEEGER E12 LEVA CAMBIO	CIRCLIP D.12 - EXTERNAL
29	33255	1		PERNO FORCH.ALB. PRIM.250 / 125.99	AXEL, MAINSHAFT FORK 250cc



4T250FIMX22-M
MOTORE - ENGINE

COMANDO CAMBIO
GEARSHIFT MECHANISM

30	F33311	1	FORCHETTA A/P 250Fi CROMATA	FORK, SECONDARY SHAFT
31	19041	1	ASTUCCIO A RULLI DHK 35/12	BUSH NEEDLE CAGE DHK 35/12

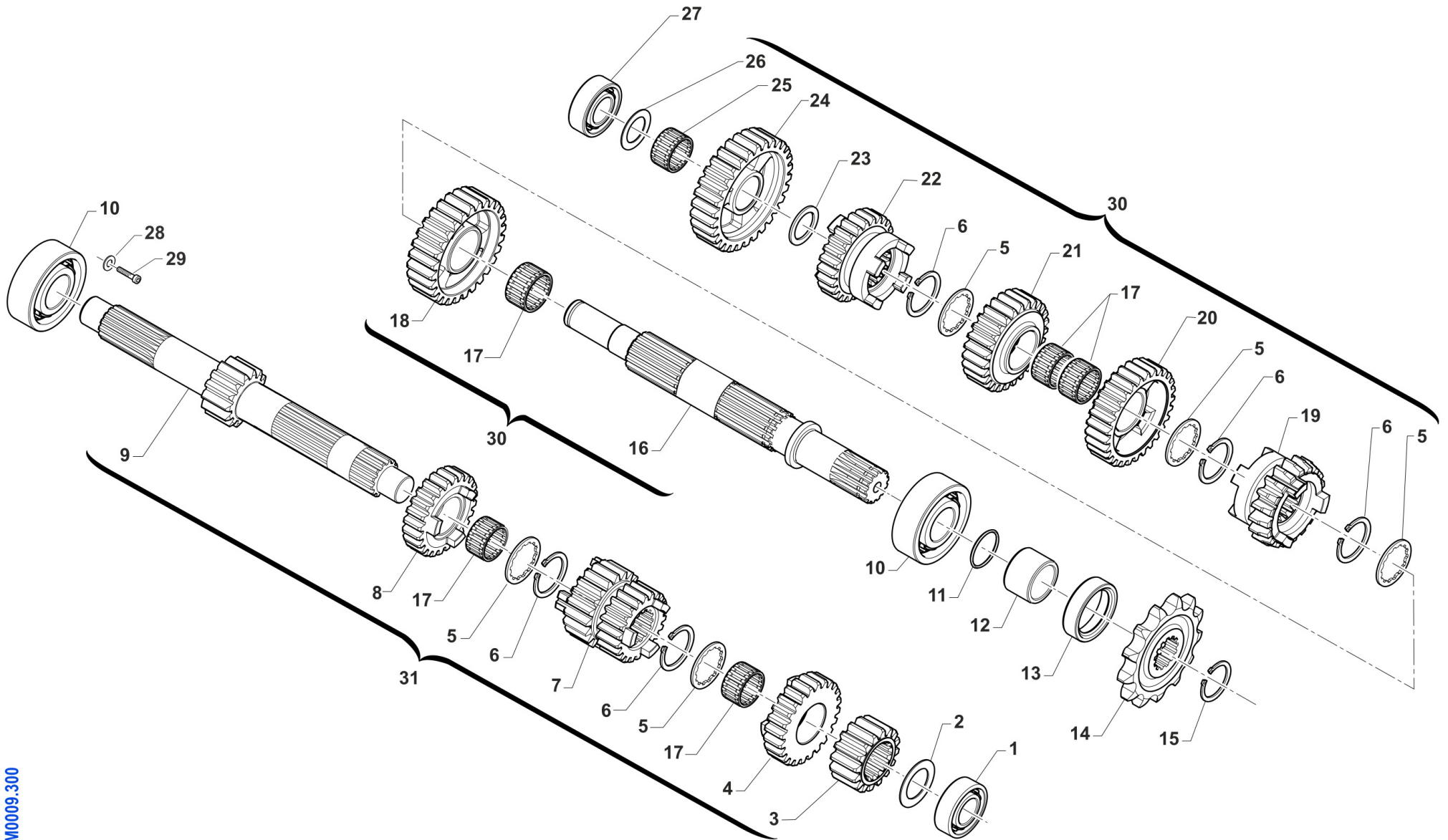

TW0009.300



4T250FIMX22-M
MOTORE - ENGINE

CAMBIO 6M
GEAR BOX

1	03254	1	CUSCINETTO A.P.4 Tempi 2RS1/C3	BUSH, MAINSHAFT 2RS/C3 4S
2	48253	1	SPESSORE CAMBIO 17X30X1 250	SPACER, GEAR BOX 250cc 17X30X1
3	F40894.1	1	INGR.2a VEL. Z16 A.P. MX/E250N	
4	F40898.1	1	INGR.6a VEL.Z20 A.P. MX/E 250N	
5	F40036.1	5	RALLA BROCCIATA DIN 5480 TRANC	WASHER GEAR DIN 5480
6	F49869	5	SEEGER SW 24 (EST.) "SEEGER"	CIRCLIP SW 24 (EXTERNAL)
7	F40103	1	INGRANAGGIO 3/4aA.P.Z16/20 300	GEAR,3/4th 16/20T MAINSH.300Fi
8	F40897.1	1	INGR.5a VEL.Z24 A.P. MX/E 250N	
9	F40893.1	1	ALBERO PRIMARIO Z14 MX/E 250N	
10	F03368	2	CUSCINETTO 62/22 C3 22x50x14	BUSH, 62/22 C3 22x50x14
11	F12320	1	O RING BOCCOLA PIGNONE 250/09	O-RING NBR 2087
12	F26421	1	DISTANZ. PIGNONE CATENA 250N	SPACER SPROCKET CHAIN 250N
13	04113	1	PARAOLIO 28X38X7 125TAG	OIL SEAL 28 x 38 x 7
14	F40889	1	PIGNONE CATENA 250N - Z13	SPROCKET 13T, DRIVE 250Fi
14	F40933	1	PIGNONE CATENA 250N - Z14	SPROCKET 14T, DRIVE 250Fi
14	F40956	1	PIGNONE CATENA 250N - Z12	SPROCKET 12T, DRIVE 250Fi
15	49217	1	SEEGER E22 ANELLO ALB/S	CIRCLIP D.22 - COUNTERSHAFT
16	F40899.1	1	ALBERO SECONDARIO MX/E 300Fi 4T	
17	F19524	5	GABBIA A RULLI 22X26X10 TAGL.	NEEDLE BEARING 22 X 26 X 10
18	F40901.1	1	INGR.2a VEL. Z28 A.S. MX/E250N	
19	F40905.1	1	INGR.6a VEL. Z19 A.S.MX/E 250N	
20	F40902.1	1	INGR.3a VEL. Z29 A.S.MX/E 250N	
21	F40903.1	1	INGR.4a VEL. Z27 A.S.MX/E 250N	
22	F40904.1	1	INGR.5a VEL. Z25 A.S.MX/E 250N	
23	F48353	1	SPESSORE PS 18X25X1	SPACER
24	F40900.1	1	INGR.1a VEL. Z30 A.S.MX/E 250N	
25	F19514	1	GABBIA A RULLI 18X22X10	NEEDLE CAGE 18X22X10
26	48012	1	RASAMENTO A/S M/M SPESS.0,5	SPACER, 26x17x0,5



4T250FIMX22-M
MOTORE - ENGINE

CAMBIO 6M
GEAR BOX

27	F03367	1	CUSCINETTO 6003 TN9C3 17x35x10	BUSH, 6003 TN9 C3 17x35x10
28	49603	1	RONDELLA M 6,4 X 12 X 1,6	WASHER 6x12
29	49480	1	VITE TCEI 6X10 UNI 5931	BOLT TCEI 6X10
30	F40888.1	1	ALBERO SEC.250Fi MX 2022 6 MARCE CPL	
31	F40887.1	1	ALBERO PRIM.250Fi MX 2022 6 MARCE CPL	

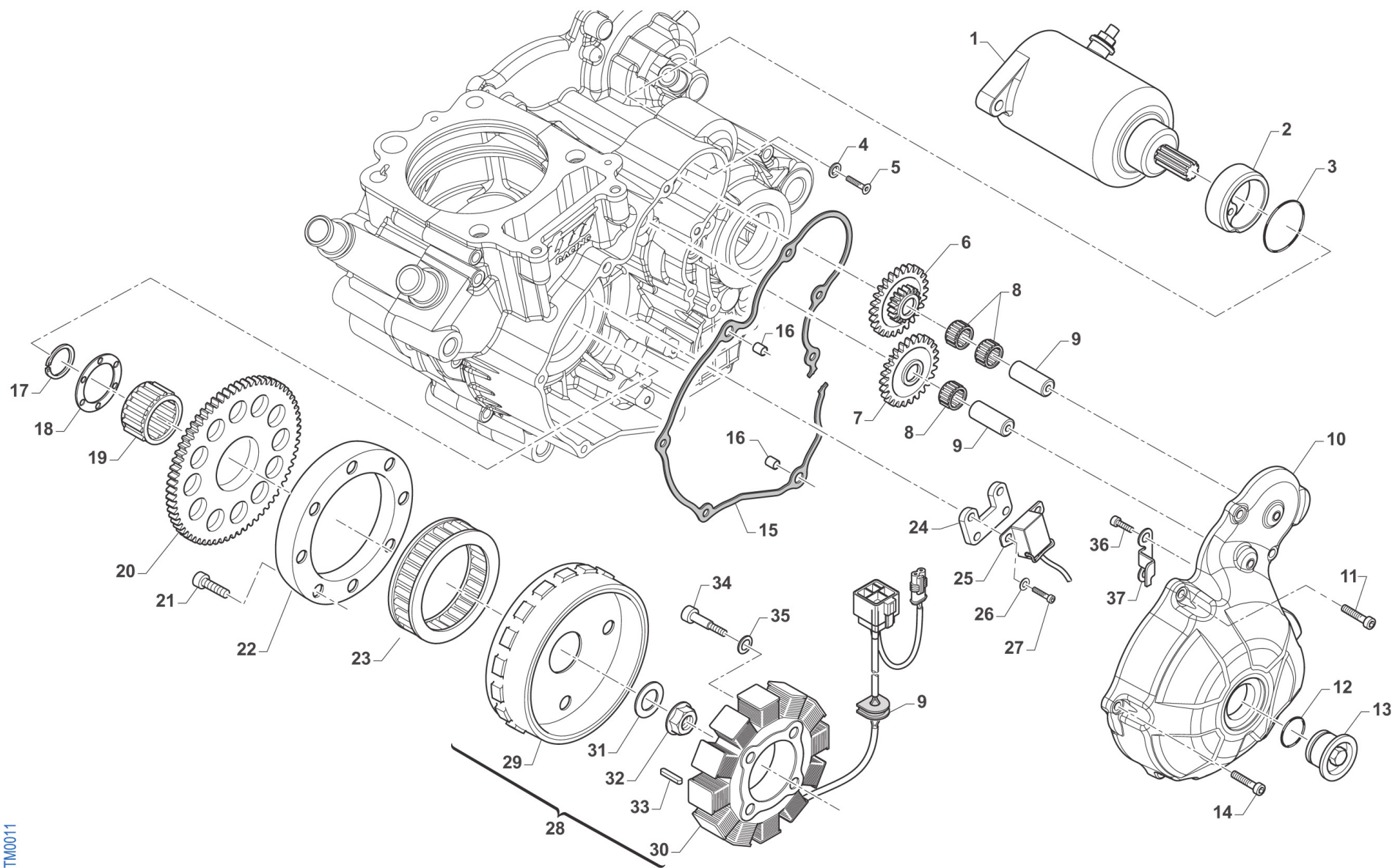

TM0011



4T250FIMX22-M
MOTORE - ENGINE

ACCENSIONE ES
IGNITION ES

10

1	F68145	1	MOTORINO AVVIAMENTO 250N M08 SM 14 A8323-048-00-000	E-STARTER ENGINE 250 4 S 08->
2	F26341	1	BOCCOLA CENTRAGGIO MOT.AVVIAM.	COLLAR, EL. STARTER
3	F12309	1	O RING 2150	O-RING, 2150
4	F49818	1	ROSETTA SPECIALE D.6 SVASATA	WASHER SPECIAL D.6
5	49399	1	VITE TSEI 5X12	BOLT TSEI 5x12
6	F40839	1	INGRANAGGIO DOPPIO RINF. E.S.	GEAR, ELECT. START
7	F40808	1	INGR. FOLLE AVVIAMENTO EL.	INTERMEDIATE GEAR
8	F19501	3	GABBIA A RULLI 10X13X10 4T	NEEDLE CAGE 10X13X10 F.S.
9	F28568	2	ALBERINO LUNGO ING. AVV.ELETTR	SHAFT, EL. STARTER GEAR
10	F30963	1	COP. ACC. 250Fi MX/ES 10/-> ATTACCO ACCENSIONE 4 FORI	COVER IGNITION 250Fi MX/ES10->
11	49477	2	VITE TCEI 5X25 UNI 5931	BOLT TCEI 5X25
12	F12322	1	O RING 2106	O-RING
13	F49833	1	TAPPO COPERCHIO ACC.250Fi	COVER CAP ALUMINIUM 250Fi
14	49476	5	VITE TCEI 5X20 UNI 5931	BOLT TCEI 5X20
15	F05829	1	GUARNIZ.COP.ACCENSIONE ES 250N	GASKET, INGNIT.COVER ES 250Fi
16	26041	2	GRANO CENTRAGGIO D.7X8 F.5,2	DOWEL PIN 7 x 8 Hole 5,2
17	F49937	1	SEEGER ALBERO E 36 4T	CIRCLIP 36 CRANKSH. E 4S
18	F26327	1	RONDELLA ACC. 37X53X2 4T	WASHER 37X50X2 4S.
19	F19506	1	GABBIA A RULLI AVV.EL.37X42X17	NEEDLE CAGE 37X42X17 E.S.
20	F40807	1	INGR. CONDOTTO AVVIAMENTO EL.	GEAR EL. STARTER
21	F49929	8	VITE TCE BASSA 6X16 (CL. 12.9)	SCREW TCE 6 X 16
22	F26385	1	ANELLO ESTERNO PESANTE R.L.KOK	EXTERNAL RING IGNITION KOKUSAN
23	F03354	1	RUOTA LIBERA MOTORINO AVV. 4T	FREE-WHEEL ELECTRIC STARTER
24	F08075	1	PIASTRINO PICK-UP 250Fi MX/ES	
25	F15478	1	PICK-UP KOKUSAN	PICK-UP KOK PU5157
26	49601	2	RONDELLA 5X11	WASHER 5x11
27	49452	2	VITE TE 8X30	



4T250FIMX22-M
MOTORE - ENGINE

ACCENSIONE ES
IGNITION ES

10

28	F15561	1	GENERATORE KOKUSAN MX E.S. KOK / SUMIT. 2V	GENERATOR KOKUSAN MX E.S.
29	F15549	1	ROTORE KOKUSAN YF9019	ROTOR, KOKUSAN YF9019
30	F15547	1	STATORE KOKUSAN YS 9018 C. KOK / SUM	
31	49613	1	RONDELLA ACCIAIO 12	STEEL WASHER 12
32	49056	1	DADO ACCENS 100/TAG/KZ 125MX/E	NUT, IGNITION 100cc
33	F49853	1	CHIAVETTA 5X3X25 UNI7510R.F.A.	WOODRUFF KEY, 5x3x25
34	49384	4	VITE TCEI 4X35	
35	49866	4	RONDELLA 4 x 12 x 1	
36	49553	2	VITE TCEI 4X8	BOLT TCEI 4X8
37	F30945	1	PROTEZIONE CAVI ACC.NE 250N	PROTECTION IGNITION WIRES 250N



4T250FIMX22-M
MOTORE - ENGINE

-

03012	4T250FIMX22-M-08	17	1
03026	4T250FIMX22-M-03	8	2
03254	4T250FIMX22-M-09	1	1
04004	4T250FIMX22-M-08	26	1
04017	4T250FIMX18-M-05	9	1
04043	4T250FIAA22-M-06	17	1
04113	4T250FIMX22-M-09	13	1
09006	4T250FIMX18-M-07	9	1
12094	4T250FIMX18-M-05	30	1
12252	4T250FIMX18-M-07	33	1
12259	4T250FIMX18-M-07	35	2
16010	4T250FIMX22-M-08	6	1
16012	4T250FIMX22-M-08	13	2
19022	4T250FIMX18-M-07	10	1
19023	4T250FIMX18-M-07	11	1
19041	4T250FIMX22-M-08	31	1
21005	4T250FIMX18-M-07	24	8

26006	4T250FIMX22-M-08	7	1
26007	4T250FIMX22-M-08	23	1
26021	4T250FIMX22-M-08	15	1
26041	4T250FIMX18-M-05	15	2
	4T250FIMX18-M-12	16	2
26050	4T250FIMX22-M-08	3	1
26060	4T250FIMX22-M-08	10	1
26061	4T250FIMX22-M-08	11	1
26062	4T250FIMX22-M-08	12	2
26095	4T250FIMX22-M-08	21	1
26211	4T250FIMX18-M-07	40	2
28100	4T250FIMX22-M-08	4	1
33255	4T250FIMX22-M-08	29	1
33256	4T250FIMX22-M-08	18	1
35050	4T250FIMX18-M-07	17	1
35262	4T250FIMX18-M-07	21	1
35264	4T250FIMX18-M-07	32	1

40310	4T250FIMX22-M-08	14	1
43049	4T250FIMX22-M-08	27	1
48012	4T250FIMX22-M-09	26	1
48250	4T250FIMX18-M-07	28	2
48253	4T250FIMX22-M-09	2	1
49056	4T250FIMX18-M-12	32	1
49060	4T250FIMX18-M-07	16	1
49119	4T250FIMX18-M-05	13	1
49125	4T250FIAA22-M-06	4	2
49202	4T250FIMX18-M-07	22	8
49212	4T250FIMX22-M-08	28	1
49217	4T250FIMX22-M-09	15	1
49255	4T250FIMX22-M-03	13	1
49267	4T250FIMX18-M-05	42	1
49384	4T250FIMX18-M-12	34	4
49396	4T250FI22-M-02	30	1
49399	4T250FIMX18-M-12	5	1
49405	4T250FIMX22-M-08	8	2



4T250FIMX22-M MOTORE - ENGINE

-

49406	4T250FIMX22-M-04	26	2
49429	4T250FIMX18-M-05	47	1
49452	4T250FIMX18-M-12	27	2
49472	4T250FIMX22-M-03	11	1
49476	4T250FIMX18-M-05	3	3
	4T250FIMX18-M-12	14	5
49477	4T250FIMX18-M-05	14	7
	4T250FIMX18-M-07	2	4
	4T250FIMX18-M-12	11	2
49478	4T250FIMX18-M-05	20	1
49480	4T250FIMX22-M-09	29	1
49481	4T250FI22-M-02	33	3
49482	4T250FI22-M-02	2	4
49483	4T250FIMX22-M-08	16	2
49484	4T250FIMX18-M-07	5	6
49485	4T250FIMX22-M-08	25	1
49487	4T250FIAA22-M-06	11	4
	4T250FIMX22-M-04	1	8
49491	4T250FIAA22-M-06	10	3

49492	4T250FIAA22-M-06	12	1
49535	4T250FIMX18-M-07	30	2
49542	4T250FIAA22-M-06	7	1
49553	4T250FI22-M-02	27	2
	4T250FIMX18-M-12	36	2
49570	4T250FIMX18-M-05	2	1
49575	4T250FIMX18-M-05	1	1
49597	4T250FIMX22-M-04	13	1
49600	4T250FIMX18-M-05	41	1
49601	4T250FIMX18-M-12	26	2
49603	4T250FIMX22-M-08	2	1
	4T250FIMX22-M-09	28	1
49604	4T250FIMX18-M-07	6	6
49613	4T250FIMX18-M-12	31	1
49638	4T250FIMX22-M-08	1	1
49676	4T250FIMX22-M-01	12	2
49702	4T250FI22-M-02	5	1
49736	4T250FIMX18-M-07	1	2
49751	4T250FIMX18-M-05	37	2

49866	4T250FIMX18-M-12	35	4
49922	4T250FIAA22-M-06	14	2
49926	4T250FIAA22-M-06	15	2
49949	4T250FIMX22-M-04	29	1
49989	4T250FI22-M-02	39	3
51073	4T250FIAA22-M-06	18	1
F01731	4T250FIMX22-M-01	7	1
F03354	4T250FIMX18-M-12	23	1
F03365	4T250FIMX18-M-05	27	1
F03367	4T250FIMX22-M-09	27	1
F03368	4T250FIMX22-M-09	10	2
F03375.4	4T250FIMX22-M-03	4	1
F03375.5	4T250FIMX22-M-03	4	1
F04363	4T250FIMX18-M-05	28	1
F04366	4T250FIAA22-M-06	3	1
F04367	4T250FIMX18-M-07	38	1
F04375	4T250FIMX22-M-03	9	1
F04388	4T250FI22-M-02	11	4
F04390	4T250FIMX18-M-05	18	1



4T250FIMX22-M
MOTORE - ENGINE

-

F05828	4T250FIMX18-M-05	16	1
F05829	4T250FIMX18-M-12	15	1
F05833	4T250FIMX18-M-05	7	1
F05841	4T250FIMX18-M-07	4	1
F05856.1	4T250FIMX22-M-01	8	1
F05856.2	4T250FIMX22-M-01	8	1
F05856.3	4T250FIMX22-M-01	8	1
F05856.4	4T250FIMX22-M-01	8	1
F05862.1	4T250FIMX22-M-01	5	1
F05863	4T250FIAA22-M-06	16	1
F06116	4T250FI22-M-02	37	1
F08003	4T250FI22-M-02	40	1
F08075	4T250FIMX18-M-12	24	1
F08456	4T250FIAA22-M-06	13	1
F09385	4T250FIMX22-M-01	4	2
F09396.2	4T250FIMX22-M-01	3	1
F10879.95	4T250FIMX22-M-01	1	1
F10879.96	4T250FIMX22-M-01	1	1
F10879.97	4T250FIMX22-M-01	1	1

F11384	4T250FIMX22-M-01	2	1
F12302	4T250FIMX18-M-05	31	1
	4T250FIMX18-M-07	44	1
F12309	4T250FIMX18-M-12	3	1
F12320	4T250FIMX22-M-09	11	1
F12322	4T250FIMX18-M-12	12	1
F12325	4T250FI22-M-02	19	2
	4T250FIMX18-M-05	21	1
F12327	4T250FIMX18-M-05	5	1
F12343	4T250FIMX18-M-05	23	1
F12344.1	4T250FIMX22-M-04	3	1
F12345.1	4T250FI22-M-02	4	1
F12346.1	4T250FI22-M-02	25	1
	4T250FIMX22-M-04	27	1
F12351.1	4T250FI22-M-02	31	1
F12356.1	4T250FIMX22-M-04	31	1
F12364	4T250FI22-M-02	3	1
F12380.1	4T250FIMX22-M-01	11	2
F13287	4T250FI22-M-02	38	1
F14158	4T250FI22-M-02	14	2

F14164	4T250FI22-M-02	15	2
F14178	4T250FI22-M-02	7	8
F15478	4T250FIMX18-M-12	25	1
F15547	4T250FIMX18-M-12	30	1
F15549	4T250FIMX18-M-12	29	1
F15561	4T250FIMX18-M-12	28	1
F16441	4T250FIMX18-M-05	40	1
F16445	4T250FIMX18-M-07	34	1
F16447.3	4T250FIMX22-M-08	22	1
F16453	4T250FIMX18-M-07	7	6
F16472	4T250FI22-M-02	10	2
F16473	4T250FI22-M-02	9	2
F16479	4T250FIMX22-M-04	15	1
F18059	4T250FIMX22-M-03	5	1
F18093	4T250FIMX22-M-03	6	1
F18111	4T250FIMX22-M-03	3	1
F18134	4T250FIMX22-M-03	1	1
F18134.1	4T250FIMX22-M-03	2	1
F19501	4T250FIMX18-M-12	8	3



4T250FIMX22-M
MOTORE - ENGINE

-

F19506	4T250FIMX18-M-12	19	1
F19510	4T250FIMX18-M-07	26	1
F19511	4T250FIMX18-M-05	52	1
F19512	4T250FIMX18-M-05	49	2
F19513	4T250FIMX18-M-05	35	3
F19514	4T250FIMX22-M-09	25	1
F19518	4T250FIMX18-M-07	37	1
F19521	4T250FIMX18-M-05	45	2
F19524	4T250FIMX22-M-09	17	5
F19526	4T250FIMX22-M-04	21	1
F19529	4T250FIMX22-M-04	4	4
F19530	4T250FIMX22-M-04	11	1
F20003	4T250FIAA22-M-06	9	1
F20004	4T250FIAA22-M-06	8	1
F21436	4T250FI22-M-02	36	1
F25256	4T250FIMX18-M-07	18	1
F25257	4T250FIMX18-M-07	23	1
F25258	4T250FIMX18-M-07	8	1

F26327	4T250FIMX18-M-12	18	1
F26341	4T250FIMX18-M-12	2	1
F26385	4T250FIMX18-M-12	22	1
F26421	4T250FIMX22-M-09	12	1
F26422	4T250FIMX18-M-07	27	1
F26428	4T250FIAA22-M-06	6	4
	4T250FIMX22-M-01	6	2
F26454	4T250FIMX22-M-08	9	1
F26455	4T250FIMX22-M-08	5	1
F26460	4T250FIMX18-M-07	43	1
F26557	4T250FI22-M-02	16	2
F26558	4T250FI22-M-02	17	2
F26575	4T250FIMX22-M-04	12	1
F26576	4T250FIMX22-M-04	16	1
F26597	4T250FI22-M-02	8	4
F26603.255	4T250FI22-M-02	6	1
F26603.260	4T250FI22-M-02	6	1
F26603.265	4T250FI22-M-02	6	1
F26603.270	4T250FI22-M-02	6	1
F26603.275	4T250FI22-M-02	6	1
F26603.280	4T250FI22-M-02	6	1

F26603.285	4T250FI22-M-02	6	1
F26603.290	4T250FI22-M-02	6	1
F26603.295	4T250FI22-M-02	6	1
F26603.300	4T250FI22-M-02	6	1
F26603.305	4T250FI22-M-02	6	1
F26603.310	4T250FI22-M-02	6	1
F26603.315	4T250FI22-M-02	6	1
F26603.320	4T250FI22-M-02	6	1
F26689	4T250FI22-M-02	12	4
F26728	4T250FI22-M-02	13	4
F28568	4T250FIMX18-M-12	9	2
F28658	4T250FIMX18-M-05	25	1
F28665	4T250FIMX18-M-05	51	1
F28679	4T250FIMX18-M-05	8	1
F28809	4T250FIMX22-M-04	10	1
F28810	4T250FI22-M-02	28	1
F28811	4T250FI22-M-02	21	1
F28812	4T250FI22-M-02	20	1
F28813	4T250FIMX22-M-04	22	1
F28835	4T250FI22-M-02	23	3
F28836	4T250FI22-M-02	22	1
F28840	4T250FIMX18-M-05	36	1
F28841	4T250FI22-M-02	24	1



4T250FIMX22-M
MOTORE - ENGINE

-

F28852	4T250FIMX22-M-04	6	1
F28869	4T250FIMX22-M-04	9	1
F28873	4T250FIMX22-M-04	7	1
F30005	4T250FIMX18-M-07	29	1
F30006	4T250FIMX18-M-07	31	1
F30015	4T250FI22-M-02	32	1
F30059	4T250FIMX18-M-05	38	1
F30060	4T250FIMX22-M-04	5	2
F30061	4T250FI22-M-02	1	1
F30068	4T250FIMX18-M-05	33	1
F30070	4T250FIAA22-M-06	1	1
F30944	4T250FIMX18-M-07	41	1
F30945	4T250FIMX18-M-12	37	1
F30960	4T250FIMX18-M-07	3	1
F30961	4T250FIMX18-M-05	12	1
F30963	4T250FIMX18-M-12	10	1
F30965	4T250FIMX18-M-05	32	1
F30966	4T250FIMX18-M-05	4	1

F32529	4T250FIMX18-M-05	17	1
F32532	4T250FIMX18-M-05	22	1
F32533	4T250FIMX18-M-05	39	1
F32555	4T250FIMX18-M-05	24	1
F32573	4T250FIMX22-M-03	10	1
F32574	4T250FIMX18-M-05	46	1
F32577	4T250FIMX18-M-05	43	3
F32578	4T250FIMX18-M-05	44	3
F33311	4T250FIMX22-M-08	30	1
F33312	4T250FIMX22-M-08	19	2
F33353.1	4T250FIMX22-M-08	20	1
F35522	4T250FIMX18-M-07	36	1
F35523	4T250FIMX18-M-07	39	1
F35541	4T250FIMX18-M-07	15	5
F35544	4T250FIMX18-M-07	19	1
F35582	4T250FIMX18-M-07	12	1
F35588	4T250FIMX18-M-07	13	8

F35596	4T250FIMX18-M-07	14	2
F40036.1	4T250FIMX22-M-09	5	5
F40038	4T250FIMX18-M-07	20	1
F40057	4T250FIMX22-M-03	12	1
F40057.1	4T250FIMX22-M-03	12	1
F40057.3	4T250FIMX22-M-03	12	1
F40061	4T250FIMX22-M-04	20	1
F40062	4T250FIMX22-M-04	8	2
F40103	4T250FIMX22-M-09	7	1
F40807	4T250FIMX18-M-12	20	1
F40808	4T250FIMX18-M-12	7	1
F40839	4T250FIMX18-M-12	6	1
F40887.1	4T250FIMX22-M-09	31	1
F40888.1	4T250FIMX22-M-09	30	1
F40889	4T250FIMX22-M-09	14	1
F40893.1	4T250FIMX22-M-09	9	1
F40894.1	4T250FIMX22-M-09	3	1



4T250FIMX22-M
MOTORE - ENGINE

-

F40897.1	4T250FIMX22-M-09	8	1
F40898.1	4T250FIMX22-M-09	4	1
F40899.1	4T250FIMX22-M-09	16	1
F40900.1	4T250FIMX22-M-09	24	1
F40901.1	4T250FIMX22-M-09	18	1
F40902.1	4T250FIMX22-M-09	20	1
F40903.1	4T250FIMX22-M-09	21	1
F40904.1	4T250FIMX22-M-09	22	1
F40905.1	4T250FIMX22-M-09	19	1
F40909	4T250FIMX18-M-05	50	1
F40933	4T250FIMX22-M-09	14	1
F40954	4T250FIMX18-M-07	25	1
F40955	4T250FIMX18-M-05	26	1
F40956	4T250FIMX22-M-09	14	1
F40997	4T250FIMX18-M-05	34	1
F48353	4T250FIMX22-M-09	23	1
F48368	4T250FIMX22-M-04	14	1

F48371	4T250FI22-M-02	29	1
F48372	4T250FIMX22-M-04	19	2
F48374	4T250FI22-M-02	26	2
F48400	4T250FI22-M-02	35	4
F49045	4T250FIMX22-M-01	10	4
F49818	4T250FIMX18-M-12	4	1
F49820.1	4T250FIAA22-M-06	5	2
F49821	4T250FIMX18-M-05	48	1
F49832	4T250FIAA22-M-06	2	1
F49833	4T250FIMX18-M-12	13	1
F49841	4T250FIMX18-M-05	6	1
F49853	4T250FIMX18-M-12	33	1
	4T250FIMX22-M-03	7	1
F49869	4T250FIMX22-M-09	6	5
F49871	4T250FI22-M-02	18	2
	4T250FIMX22-M-04	17	1
F49874	4T250FI22-M-02	34	4
F49875	4T250FIMX22-M-01	9	2
F49883	4T250FIMX22-M-04	25	2
F49884	4T250FIMX22-M-04	30	1

F49913	4T250FIMX18-M-05	19	1
F49920	4T250FIMX18-M-05	11	1
F49925	4T250FIMX18-M-05	10	1
F49929	4T250FIMX18-M-12	21	8
F49937	4T250FIMX18-M-12	17	1
F65104	4T250FIAA22-M-06	19	1
F66510	4T250FIMX18-M-05	29	1
F68145	4T250FIMX18-M-12	1	1
F70370	4T250FIMX18-M-07	42	1
F70404	4T250FIMX22-M-04	23	1
F70408	4T250FIMX22-M-04	28	1
F70413	4T250FIMX22-M-04	24	1
F70422	4T250FIMX22-M-04	18	1