



USES AND
RACOMMENDS



www.tmracing.it

TM Racing SpA - Via Fano, 6
61122 Pesaro - ITALY
Phone: +39 0721 25113

4T450FIMX22-M

MOTORE
ENGINE

08/03/2022



INFORMAZIONI GENERALI

Il presente catalogo serve per richiedere con esattezza le parti di ricambio.

Nelle ordinazioni indicare:

1) Il numero di matricola del Telaio che è stampigliato sul lato destro del canotto di sterzo. Nei modelli EN, SMR, SMR il numero di matricola è riportato anche su una targhetta posta sul lato sinistro (Vedi foto).

2) il numero di serie del Motore. E' posto sulla sinistra del motore tra la leva cambio e i coperchio accensione (Vedi foto).

3) Il codice dei particolari seguito dalla descrizione.

4) Il colore per i pezzi verniciati o comunque colorati.

Le indicazioni destra e sinistra si riferiscono ai lati del veicolo rispetto al senso di marcia.

Foto e disegni sono solo a scopo informativo e potrebbero non corrispondere esattamente alle caratteristiche dei prodotti.

GENERAL INFORMATION

The present spare parts catalogue enables one to order exactly the right spare part.

When ordering specify:

1) The frame serial number. It is embossed on the right side of the steering metal tube. In the EN, SMR and SMR models, the serial number is also stated on a plate positioned on the left hand side (See photo).

2) The engine serial numer. It is located on the left side of the engine between the gear lever and the ignition cover (See photo).

3) The part's code number followed but its description.

4) Indicate colour for painted or colored parts.

References to right and left apply to the vehicle in terms of its direction of movement.

Photos and drawings are for informational purposes only and may not exactly match the characteristics of the products.

NOTE – LEGENDA

MY

NOVITA' INTRODOTTA DIFFERENTE O NON PRESENTE NEL MODELLO DELL'ANNO PRECEDENTE

PART DIFFERENT OR NOT PRESENT IN THE REVIOUS YEAR MODEL

5M

MOTORE CON CAMBIO A 5 MARCE
ENGINE WITH 5 GEARS SPEED

6M

MOTORE CON CAMBIO A 6 MARCE
ENGINE WITH 6 GEARS SPEED

KS

MOTORE CON SOLO KICK STARTER
ENGINE WITH KICK STARTER ONLY

ES

MOTORE CON AVVIAMENTO ELETTRICO
ENGINE WITH ELECTRIC STARTER

X

RICAMBIO NON DISPONIBILE ALLA VENDITA
PART CAN NOT BE SOLD SEPARATELY



Le illustrazioni riportate in questo manuale sono fornite solo come riferimento e possono variare dal prodotto effettivo,

Dati indicativi soggetti a modifiche senza impegno di preavviso.

The illustrations in this manual are for reference only and may vary from the actual product.

All data are subject to modification without prior notice.



4T450FIMX22-M
MOTORE - ENGINE

BASAMENTO E CILINDRO.....	4
TESTA - HEAD.....	7
DISTRIBUZIONE - VALVES COVER.....	10
ALBERO MOTORE E PISTONE - CRANKSHAFT AND PISTON.....	13
LUBRIFICAZIONE - LUBRIFICATION.....	15
FRIZIONE - CLUTCH.....	18
COMANDO CAMBIO - GEARSHIFT MECHANISM.....	21
CAMBIO - GEAR BOX.....	24
ACCESNIONE ES.....	27
-	30

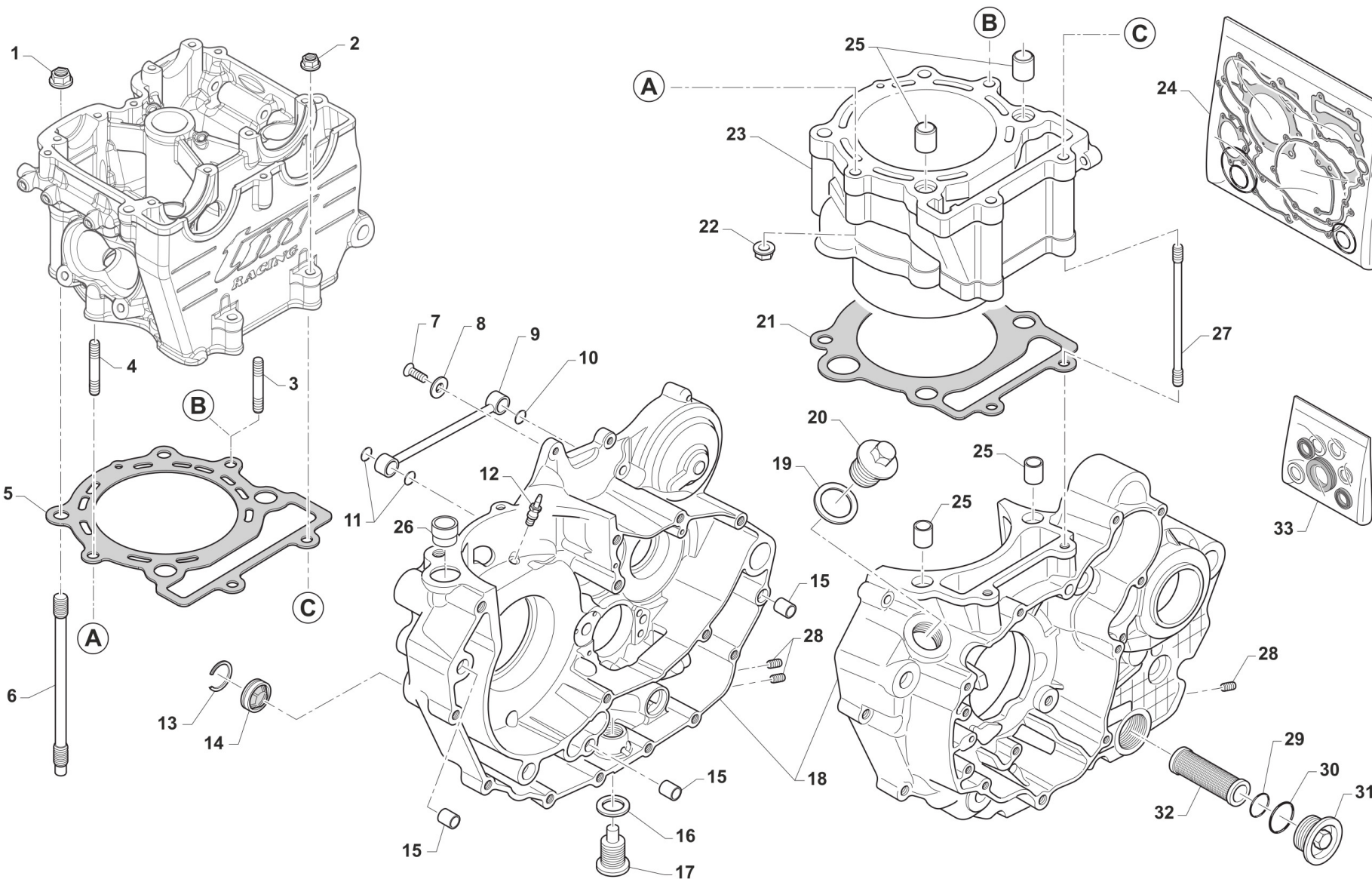

TM0143.01



4T450FIMX22-M
MOTORE - ENGINE

BASAMENTO E CILINDRO

1

1	49681	4	DADO M 10 X 1,25 CH 14 FLANG. AUTOBLOCK	NUT M10x1,25 FLANGED SELF-LOCK
2	49676	2	DADO M 6X1 FLANG. AUTOBL.ACC.	NUT, FLANGED M6 X 1 S.B.
3	F49926	1	PRIGIONIERO M8 TESTA/CIL450/53	STUD M8 HEAD / CYLINDER 450cc
4	F49926.1	1	PRIGIONIERO M8 X 62,5	
5	F05865	1	HEAD GASKET 450 SMK D. 95	
6	F49980	4	PRIGIONIERO M10X1.25 L.177 ASP	STUD M10 X 1.25 X 177
7	49399	1	VITE TSEI 5X12	BOLT TSEI 5x12
8	49604	1	RONDELLA 6 X18 X 1,6	WASHER 6x18
9	F32506	1	CONDOTTO OLIO PER CAMBIO/CIL.	OIL HOSE FOR GEAR BOX/ CIL.
10	F12302	1	O RING 108 PIOGGIA CAMBIO 4T	O-RING, 108 GEAR F.S.
11	F12301	2	O RING 106 4T PIOGGIA CAMBIO	O-RING, 106 GEAR F.S.
12	F32515	1	UGELLO LUBRIFICAZIONE SPINOTTO	COOLING PISTON PIN, OIL JET
13	F49923	1	SEEGER OBLO' OLIO 450Fi SB 35	CIRCLIP BR 35
14	F04355	1	OBLO' LIVELLO OLIO DIAMETRO 35 X 6 mm	WINDOW, OIL LEVEL D. 35 MM
15	F26428	3	GRANO RIFERIMENTO 12X13 F10.2	GRUB SCREW 12X13 H.10,2mm
16	F49933	1	RONDELLA ALL 16X24X1,5 4T	WASHER 16X24X1,5 ALUM.
17	F49905.1	1	TAPPO OLIO C/CALAM. 4T	OIL PLUG WITH MAGNET 4S
18	F30031	1	BASAMENTO MOT. 450Fi ES 2015	
19	F49920	1	RONDELLA ALL 20.4X26X1.5	WASHER 20,4X26X1,5 ALUM.
20	F49925	1	TAPPO CARICO OLIO M20X1.5	OIL PLUG M20X1,5
21	F05843.1	1	GUARN.CIL/BAS D.108.5 SP,0,3	GASKET, CYL D.108.5 0.30 mm
21	F05843.2	1	GUARN.CIL/BAS D.108.5 SP,0,4	GASKET, CYL D.108.5 0.40 mm
21	F05843.3	1	GUARN.CIL/BAS D.108.5 SP,0,5	GASKET, CYL D.108.5 0.50 mm
21	F05843.4	1	GUARN.CIL/BAS D.108.5 SP,0,6	GASKET, CYL D.108.5 0.60 mm
22	49640.85	2	DADO M 8 FLANG.CHIAVE 12x 85cc	NUT M8 FLANGED 12mm TOOL 85cc
23	F01710	1	CILINDRO 450 CC 4T D. 95	CYLINDER 450cc 4 Str. D. 95
24	F05830.450K	1	KIT GUARNIZIONI + OR 4T 450Fi SMK	
25	F26301	4	GRANO RIF. 14X9.5 F.12.2 4T	GRUB SCREW 14X9.5 F12.2 F.S.



4T450FIMX22-M
MOTORE - ENGINE

BASAMENTO E CILINDRO

1

26	F26403	1	TUBO DI COLLEGAMENTO MOD. 05	
27	F49922.1	2	PRIGIONIERO M 6 x 125 450	
28	F49972	3	GRANO M10X12	
29	F12312	1	O RING FILTRO OLIO P.ASPIRAZ.+LEV.	O-RING, OIL FILTER
30	F12311	1	O RING TAPPO FILTRO OLIO P.AS.	O RING OIL FILTER CAP
31	F32512	1	TAPPO FILTRO ASPIRAZIONE OLIO	OIL FILTER PLUG
32	F32511	1	FILTRO ASP.POMPA MANDATA OLIO	FILTER, OIL PUMP
33	04036	1	KIT PARAOLIO 450/530	OIL SEAL KIT 450/530 cc

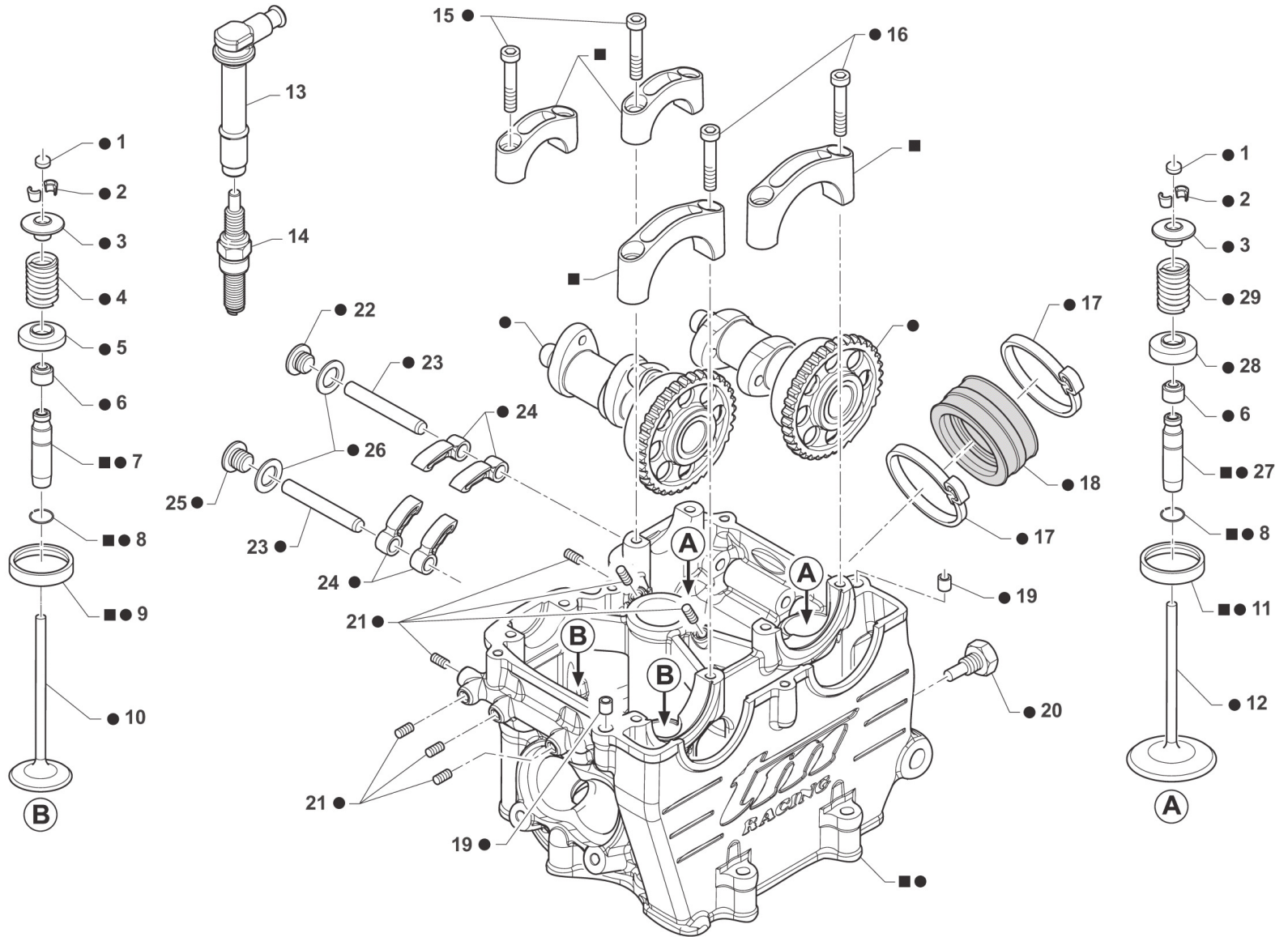
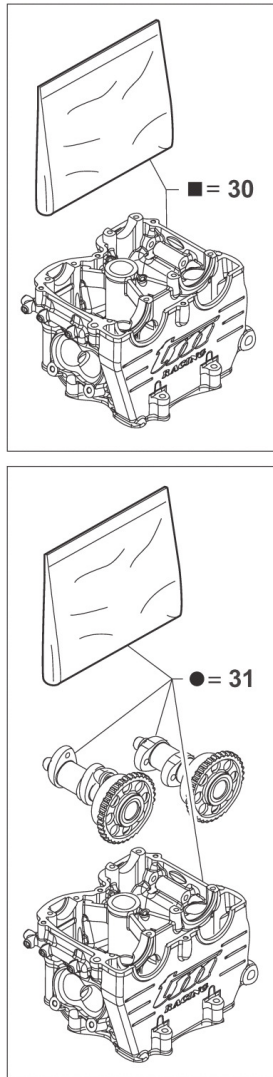



4T450FIMX22-M
MOTORE - ENGINE

TESTA
HEAD

1	F26337.270	1	PASTIGLIA REGOLAZ.GIOCO 2,70	SHIM, VALVE ADJUSTING 2.70
1	F26337.275	1	PASTIGLIA REGOLAZ.GIOCO 2,75	SHIM, VALVE ADJUSTING 2.75
1	F26337.280	1	PASTIGLIA REGOLAZ.GIOCO 2,80	SHIM, VALVE ADJUSTING 2.80
1	F26337.285	1	PASTIGLIA REGOLAZ.GIOCO 2,85	SHIM, VALVE ADJUSTING 2.85
1	F26337.290	1	PASTIGLIA REGOLAZ.GIOCO 2,90	SHIM, VALVE ADJUSTING 2.90
1	F26337.295	1	PASTIGLIA REGOLAZ.GIOCO 2,95	SHIM, VALVE ADJUSTING 2.95
1	F26337.300	1	PASTIGLIA REGOLAZ.GIOCO 3,00	SHIM, VALVE ADJUSTING 3.00
1	F26337.305	1	PASTIGLIA REGOLAZ.GIOCO 3,05	SHIM, VALVE ADJUSTING 3.05
1	F26337.310	1	PASTIGLIA REGOLAZ.GIOCO 3,10	SHIM, VALVE ADJUSTING 3.10
1	F26337.315	1	PASTIGLIA REGOLAZ.GIOCO 3,15	SHIM, VALVE ADJUSTING 3.15
1	F26337.320	1	PASTIGLIA REGOLAZ.GIOCO 3,20	SHIM, VALVE ADJUSTING 3.20
1	F26337.325	1	PASTIGLIA REGOLAZ.GIOCO 3,25	SHIM, VALVE ADJUSTING 3.25
1	F26337.330	1	PASTIGLIA REGOLAZ.GIOCO 3,30	SHIM, VALVE ADJUSTING 3.30
1	F26337.335	1	PASTIGLIA REGOLAZ.GIOCO 3,35	SHIM, VALVE ADJUSTING 3.35
1	F26337.340	1	PASTIGLIA REGOLAZ.GIOCO 3,40	SHIM, VALVE ADJUSTING 3.40
2	F14121	8	SEMICONO Diam. 5,5	VALVE COLLETS D.5,5
3	F26701	4	PIATTELLO SUPERIORE MOLLE F16472 / 73 450 4T	
4	F16473	2	SET MOLLA EST. + MOLLA INT. SCAR.	EXTER. & INTER.SPRINGS EXHAUST
5	F26724	2	PIATTELLO INF. MOLLA F16473 SCAR. 450 4T FF SMX KIT SERIE (PER F26701)	
6	F04356	4	PARAOLIO VALVOLA 4T VSS-305	VALVE-STEAM SEALING VS-3002
7	F26470	2	GUIDA VALVOLA SCA.SINTER.L.SEM	
8	F49910	4	SEEGER RW D.10 4T	CIRCLIP RW D.10 4S
9	F26373	2	SEDE VALVOLA SC. DE 33.5	SEAT, EXHAUST VALVE E.D. 33,5
10	F14160	2	EXHAUST DIA.32X5.5 TI VALVE	
11	F26372	2	SEDE VALVOLA ASP. DE 39	
12	F14154	2	INLET DIA.39X5.5X99 TI VALVE	
13	F21421	1	PIPETTA CANDELA RESISTIVA 250/450 F.F.	CAP, SPARK PLUG 250Fi
14	F06116	1	CANDELA NGK R0451B-8	SPARK PLUG NGK R0451B-8



4T450FIMX22-M
MOTORE - ENGINE

TESTA
HEAD

15	49486	4	VITE TCEI 6X30 UNI 5931	BOLT TCEI 6X30
16	49487	4	VITE TCEI 6X35 UNI 5931	BOLT TCEI 6X35
17	51069	2	FASCETTA SM9 D.62	CLAMP D.62 mm
18	F13255	1	COLLETTORE ASPIRAZION.GOMMA 4T	RUBBER INTAKE MANIFOLD F.S.
19	26041	2	GRANO CENTRAGGIO D.7X8 F.5,2	DOWEL PIN 7 x 8 Hole 5,2
20	F08003	1	SENSORE TEMP. ACQUA WTS 09/02	SENSOR, WATER TEMPERATURE
21	49702	7	GRANO 5X 6 VALV.SC.MARTELLETTO	GRUB SCREW 5 X 6 INLET VALVE
22	F49066	1	TAPPO M8X1,25 L=7MM	
23	F28692	2	ALBERINO ROTAZ.BILANC. 450/660	
24	F28711	4	BILANCERE A DITO D.W.E.	FINGER FOLLOWER D.W.
25	F49823	1	TAPPO ALBERINO ROT.BILANC.250N e CARTER	PLUG, SHAFT 250N
26	F49939	2	RONDELLA RAME 8 X13 X 1,5	WASHER COPPER 8,5X13X1,5
27	F26469	2	GUIDA VALVOLA ASP.SINTER.L.SEM	
28	F26723	2	PIATTELLO INF. MOLLA F16472 ASP. 450 4T FF SMX KIT SERIE (PER F26701)	
29	F16472	2	SET MOLLA EST. + MOLLA INT. ASP.	EXTER. & INTER.SPRINGS INLET
30	F02890.1	1	TESTA SEMI-CPL 450 SMK 450 MX/22	
31	F02890.4	1	TESTA CPL 450 MX ES MY 22	

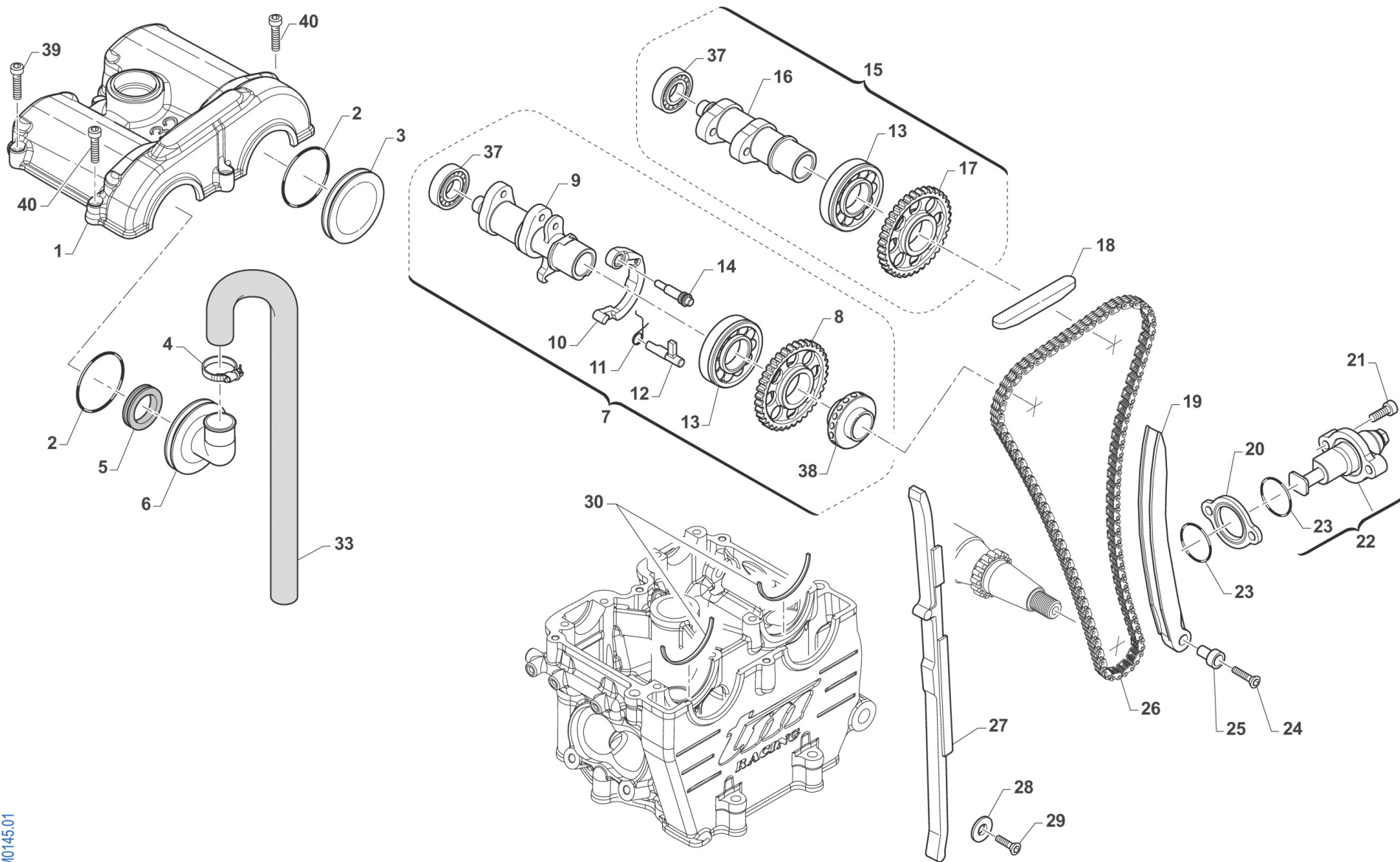

TM0145.01



4T450FIMX22-M
MOTORE - ENGINE

DISTRIBUZIONE
VALVES COVER

1	F30008	1		COPERCHIO TESTA 450 FF MX / SMK	
2	F12307	2		O RING 3156 COPER.C.A.CAMMES 4T	O-RING, 3156 CAMMES COVER F.S.
3	F30832	3		COPERCHIETTO A CAMMES 04	
4	51073	1		FASCETTA 10/19	CLAMP 10 / 19 mm
5	F04361	1		PARAOLIO 20 30 05	OIL SEAL 20x30x5
6	F30868	1		COPERCHIETTO CAMME X SF.A CENT	
7	F28874	1		ALBERO A CAMME SCA CPL FS4 450 MX FF	
8	F40951	1		RUOTA DENT.C.95RH2015SCA.Z32FF	
9	F28872	1	ELECTRIC STARTER	ALBERO A CAMME SCARICO 450 FF	
10	F26435	1		LEVA DECOMPRESSORE AUTO 250N	
11	F16435	1		MOLLA DECOMPR.AUTOMAT.ACC.CARB	
12	F26509	1		CAMMA ROT. DECOMP. AUTO 450FF	
13	F03363	2		CUSCINETTO ALBERI CAMMES250/09	BEARING 6905NR C3 - CAMS 250Fi
14	F26508	1		PERNO LEVA DECOMPRESSORE TESTA 450 SMK	
15	F28875	1		ALBERO A CAMME ASP CPL FA10 450 MX FF	
16	F28723	1		ALBERO A CAMME 450/660FFASFA10	
17	F40950	1		RUOTA DENT.C.95RH2015ASP.Z32FF	
18	F70309	1		PATTINO SUP. CATENA DISTR. 4T	GUIDE, TOP, HEAD COVER
19	F70380	1		PATTINO MOBILE 450 SMK	
20	F70326.5	1		DISTANZIALE TENSIONATORE 5 mm	
21	49485	2		VITE TCEI 6X25 UNI 5931	BOLT TCEI 6x25
22	F70354	1		TENSIONATORE AUTOMATICO 07/->	AUTOMATIC CHAIN TENSIONER 2007
23	12012	2		O RING TENDICATENA 4T	O RING CHAIN TENSIONER 4S
24	49407	1		VITE TSEI 6X25	BOLT TSEI 6X25
25	F49826	1		BOCCOLA VITE SPEC.FIS.PAT.MOB.	BUSH SPEC. BOLT
26	F70345	1		CATENA LAR. DISTRIBUZIONE P130	CAM CHAIN, 130L
27	F70400	1		PATTINO FISSO 450 SMK	
28	49603	1		RONDELLA M 6,4 X 12 X 1,6	WASHER 6x12



4T450FIMX22-M
MOTORE - ENGINE

DISTRIBUZIONE
VALVES COVER

3

29	49399	1	VITE TSEI 5X12	BOLT TSEI 5x12
30	F26433	2	SEMI-ANELLO DIAM.42 250Fi	RETAINER, CAM BEARING 250Fi
37	F03371	2	CUSCINETTO 6001 TN9 C3 ALB.CAM	BUSH 6001 TN9 C3 CAM SHAFT
38	F32534	1	CENTRIFUGATORE X SF.OLIO.CENTR 450 FF	
39	49476	4	VITE TCEI 5X20 UNI 5931	BOLT TCEI 5X20
40	49477	2	VITE TCEI 5X25 UNI 5931	BOLT TCEI 5X25

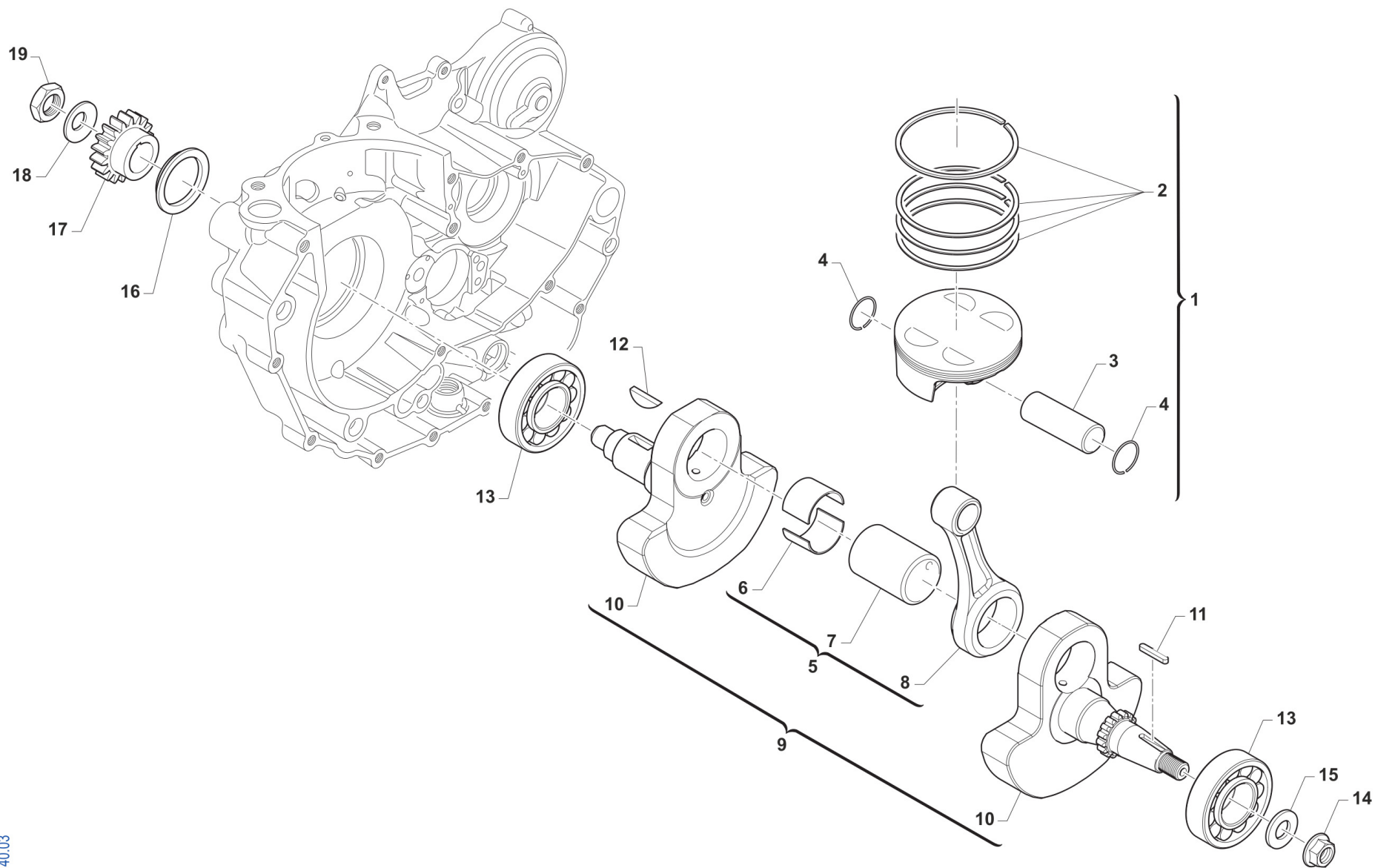

0140.03



4T450FIMX22-M
MOTORE - ENGINE

ALBERO MOTORE E PISTONE
CRANKSHAFT AND PISTON

4

1	F10871.94	1	PISTONE 450Fi SMK ES 94,94 CPL	
1	F10871.95	1	PISTONE 450Fi SMK ES 94,95 CPL	
1	F10871.96	1	PISTONE 450Fi SMK ES 94,96 CPL	
2	F11389	1	RING KIT 9500ZV	
3	F09393.1	1	SPINOTTO 19X11.0X40 BIC. DLC	
4	F09395	2	ANELLINO D.19X1.2 VP	CIRCLIP 19X1,2 VP
5	F18130	1	BIELLA 450 BRONZINE CPL D39XD.19 I.108	
6	F03376	2	BRONZINE CP (S.C.)BIELLA 35X39X20	
7	F18060	1	ASSE ACCOPP. D.35X60,8 X BRONZINE	
8	F18058	1	BIELLA D39XD.19 I.108X BRONZIN	
9	F18131	1	ALBERO MOTORE 450 SMK CPL BRONZINE	
10	F18131.1	1	COPPIA SEMIALBERI 450 SMK BRONZINE (F18117+F18118)	
11	F49853	1	CHIAVETTA 5X3X25 UNI7510R.F.A.	WOODRUFF KEY, 5x3x25
12	49012	1	CHIAVETTA PIGNONE COPPIA 250	WOODRUFF KEY, 250/300 19x7,5x5
13	F03352	2	CUSCINETTO 6306/C3E BANCO450cc	BUSH, CRANKSHAFT 400F 6306
14	49056	1	DADO ACCENS 100/TAG/KZ 125MX/E	NUT, IGNITION 100cc
15	49613	1	RONDELLA ACCIAIO 12	STEEL WASHER 12
16	F26315	1	DISTANZIALE PIGNONE COPPIA 4T	COLLAR PRIMARY GEAR 4S
17	40248	1	PIGN.COPPIA PRIM. 250 Z20 END. ENDURO M.99 MX/END 94/98	PRIMARY DRIVE GEAR 20T 250 END
18	F49917	1	MOLLA A TAZZA 40X20.4X1	SPRING, 40X20.4X1
19	F49916	1	DADO ALBERO MOTORE 20X1.5 4T	NUT, CRANKSHAFT 20X1.5 4 Str.

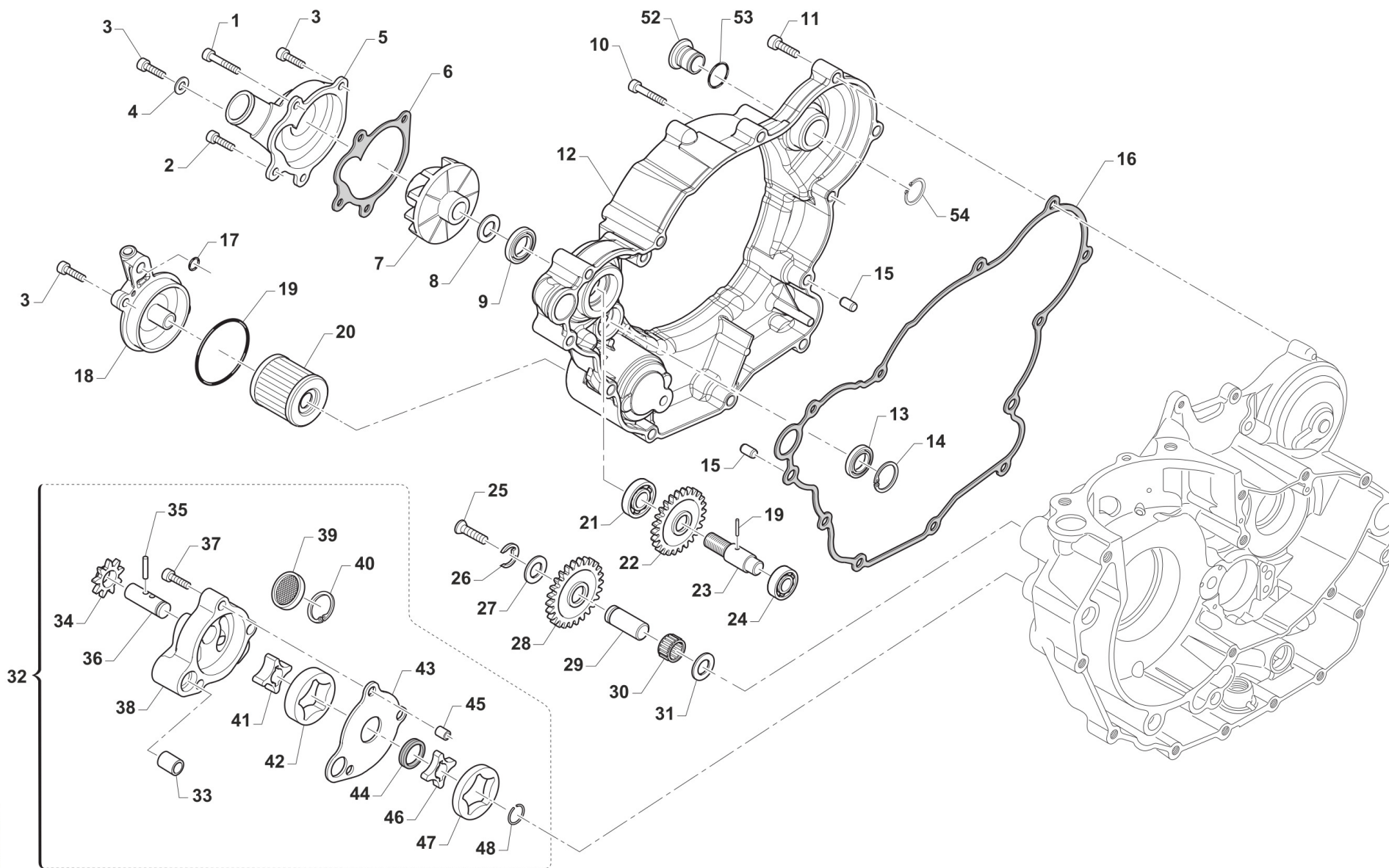

TM 0134.02



4T450FIMX22-M
MOTORE - ENGINE

LUBRIFICAZIONE
LUBRIFICATION

1	49570	1	VITE TCEI 5X50 UNI 5931	SCREW TCEI 5X50
2	49578	1	VITE TCEI 5X55	BOLT TCEI 5X55
3	49476	4	VITE TCEI 5X20 UNI 5931	BOLT TCEI 5X20
4	49104	1	RONDELLA 6 x 10 x 1,5 ALLUMINIO	WASHER 6 x 10 x 1.5 ALUMINUM
5	F30796	1	COPERCHIO POMPA ACQUA 4T 04	COVER, WATER PUMP 4S 04/->
6	F05822	1	GUARNIZIONE COP.POMPA ACQUA PF	GASKET, COVER WATER PUMP PF
7	F28661	1	GIRANTE POMPA ACQUA 4T MOD.08	IMPELLER, H2O 4S M. 08/->
8	49603	1	RONDELLA M 6,4 X 12 X 1,6	WASHER 6x12
9	04017	1	PARAOLIO CENTRIFUGA 06 +MF1TAG	OIL SEAL 8 X 22 X 7 TC
10	49485	1	VITE TCEI 6X25 UNI 5931	BOLT TCEI 6x25
11	49486	9	VITE TCEI 6X30 UNI 5931	BOLT TCEI 6X30
12	F30979	1	CARTER EST.TRASM./FRIZ. 4T MY 12->	COVER,TRAN./CLUTCH 450 4S 12->
13	F04352	1	PARAOLIO 14-22-4 TIPO A 4T	OIL SEAL 14-22-4 TYPE A F.S.
14	F49913	1	SEEGER I 23	CIRCLIP INT. 23
15	F26304	2	GRANO RIFERIMENTO 6.5X8X9.5 4T	GRUB SCREW 6.5X8XX9.5 4S
16	F05821	1	GUARNIZIONE COPERC.TRASMIS. PF	GASKET, CLUTCH COVER INT 04/->
17	F12302	1	O RING 108 PIOGGIA CAMBIO 4T	O-RING, 108 GEAR F.S.
18	F30965	1	COPERCHIO FILTRO OLIO 250Fi 11	CAP, OIL FILTER 250Fi 11->
19	12094	1	O RING COP. FILTRO OLIO	O RING OIL FILTER COVER
20	F66510	1	FILTRO OLIO 4Tempi HF 141	OIL FILTER HF - 141
21	F03351	1	CUSCINETTO 6001 POMPA ACQUA 4T	BUSH, WATER PUMP 4S 6001
22	F40973	1	INGRANAGGIO POMPA ACQUA Z19 X 40244/40248	
23	F28660	1	ALBERINO POMPA ACQUA 4T D.8	AXLE WATER PUMP F.S. D.8mm
24	F03350	1	CUSCINETTO POMPA ACQUA 4T	BUSH, WATER PUMP F.S. 6000 C3
25	49429	1	VITE TSEI 4X35	BOLT TSEI 4X35
26	F49903	1	ANELLO ELASTICO RA 9 DIN 6799 4T	CIRCLIP RA 9 DIN 6799 4S
27	19021	2	RONDELLA X GABBIA RULLI AS1024	WASHER, NEEDLE CAGE AS 1024
28	F40802	1	RUOTA DENTATA FOLLE Z 22 4T	GEAR FREE 4S 22T



4T450FIMX22-M
MOTORE - ENGINE

LUBRIFICAZIONE
LUBRIFICATION

29	F28501	1	ALBERINO RUOTA FOLLE P.OLIO 4T	
30	F19501	1	GABBIA A RULLI 10X13X10 4T	NEEDLE CAGE 10X13X10 F.S.
31	49488	1	VITE TCEI 6X40	BOLT TCEI 6x40
32	F32508.450	1	POMPA OLIO COMPLETA 4T 450	
33	F26303	1	BOCCOLA RIFERIMENTO 12X10 4T	COLLAR 12X13 F.S.
34	F40801	1	RUOTA DENTATA POMPA OLIO 4TZ15	GEAR OIL PUMP 4S 15T
35	F19500	3	RULLO D.3 X 17.8 4T	PIN D.3 X 17,8 F.S.
36	F28533	1	ALBERINO POMPA OLIO MOD.03	SHAFT, OIL PUMP M.2003
37	49487	1	VITE TCEI 6X35 UNI 5931	BOLT TCEI 6X35
38	F30706	1	POMPA OLIO 4T NUDA	ROTOR HOUSING 250/400 F.S.
39	F32500	1	FILTRO LAMIERA ASP.POMPA OLIO	OIL SCREEN
40	F49915	1	SEEGER I28 FILTRO COPPA OLIO (J28 x fori)	SEEGER OIL FILTER
41	F32503	1	ROTORE INT. ALTO POMPA OLIO 4T	INTERNAL OILPUMP ROTOR H.
42	F32502	1	ROTORE EST. ALTO POMPA OLIO 4T	EXTERNAL OILPUMP ROTOR H.
43	F32501	1	SEPARATORE POMPE OLIO 4T	SEPARATOR OIL PUMPS 4S
44	F04354	1	PARAOLIO G 12X16X3 POMPA OLIO	OIL SEAL G 12/13/3 OIL PUMP
45	26041	1	GRANO CENTRAGGIO D.7X8 F.5,2	DOWEL PIN 7 x 8 Hole 5,2
46	F32514	1	ROTORE INT.POMPA MANDATA H6mm	INTERNAL OILPUMP ROTOR
47	F32513	1	ROTORE EST.POMPA MANDATA H6mm	EXTERNAL OILPUMP ROTOR
48	F49902	1	SEEGER WR 12 4T - FIG. K11/K12	CIRCLIP WR 12
49	49711	1	GRANO 6X 6	
50	49480	1	VITE TCEI 6X10 UNI 5931	BOLT TCEI 6X10
51	49702	1	GRANO 5X 6 VALV.SC.MARTELLETTO	GRUB SCREW 5 X 6 INLET VALVE
52	F26745	1	TAPPO FORO ALBERINO M/M 450 4T	
53	12029	1	O RING TAPPO M 0160-20	
54	49216	1	SEEGER E20 PIGN.-CAMBIO-COPPIA	CIRCLIP D.20 - EXTERNAL

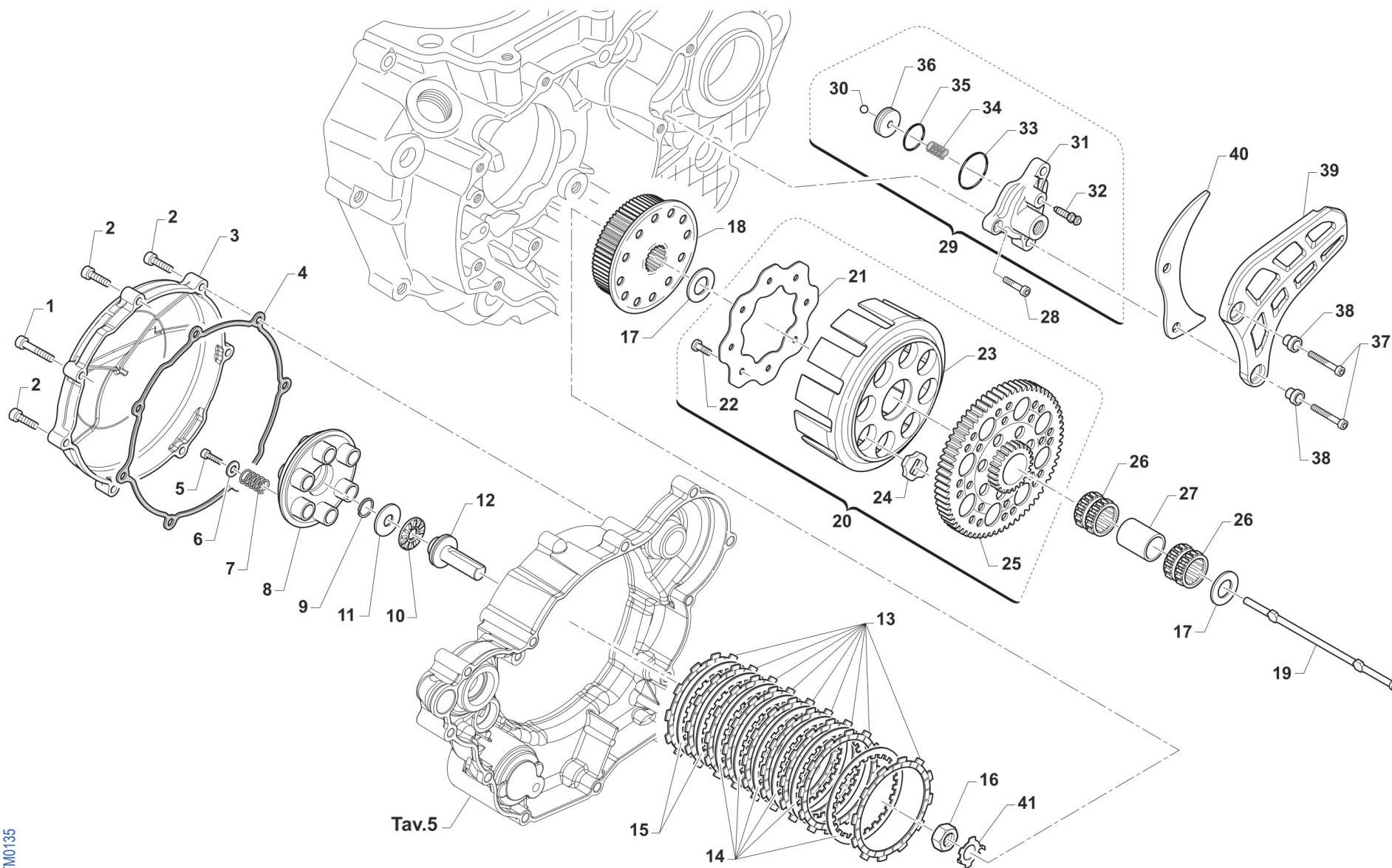

TM0135



4T450FIMX22-M
MOTORE - ENGINE

FRIZIONE
CLUTCH

1	49576	1	VITE TCEI 5X70	BOLT TCEI 5X70
2	49477	6	VITE TCEI 5X25 UNI 5931	BOLT TCEI 5X25
3	F30795	1	COPERCHIO FRIZIONE 4T 04 ALTO	CLUTCH COVER 4 STR.M.04 HIGH
4	F05820	1	GUARNIZ. EST. COPERCHIO FRIZ.	GASKET, CLUTCH COVER EXT 04/->
5	49355	6	VITE TE F/R 6X16 Ch.8	BOLT 6X16 T.8
6	49604	6	RONDELLA 6 X18 X 1,6	WASHER 6x18
7	F16453	6	MOLLA FRIZIONE 2/4T 250/450	SPRING, CLUTCH 2/4T 250/450
8	25253	1	PIATTO SPING. 250/300 + 4T	PLATE, CLUTCH PRESSURE
9	09006	1	ANELLINO FERMA SPINOTTO 80/85/100	CLIP, PISTON PIN 80/85/100cc
10	19022	1	GABBIA A RULLI RAD. AXK 1528	BUSH CAGE AXK 1528, RADIAL
11	19023	1	RONDELLA GABBIA RULLI AS 1528	WASHER, NEEDLE CAGE AS 1528
12	F35582	1	FUNGO FRIZIONE IDRAULICA 2015	PIECE, CLUTCH LIFTER
13	F35567	9	DISCO FRIZ. GUARN. ADLER 2,75	CLUTCH PLATE, FIBER ADLER 2,75
14	35250	6	DISCO FRIZ. ACC. 1,8 mm 250+4T	CLUTCH PLATE, STEEL 1,8mm 250
15	35254	2	DISCO FRIZ. ACC. 1,5 mm 250+4T	CLUTCH PLATE, STEEL 1,5mm94/98
16	49060	1	DADO TAMBUR.FRIZ. ALB.PRIM. 250/300 M18X1.5	NUT, CLUTCH CENTER 250cc
17	48250	2	SPESSORE COPPIA PRIMARIA 250	SPACER, PRIMARY GEAR 250cc
18	F25255	1	TAMBURELLO FRIZ. ALTO 4T	HIGH CLUTCH CENTER 530/600F
19	F35578	1	ASTINA FRIZIONE IDRAULICA 450F	PIN, IDRAULIC CLUTCH 450 4S
20	F40938	1	COPPIA PRIM CPL 4T z57 C/ALTA	PRIMARY DRIVE GEAR ASSY 4S 57T
21	35262.1	1	DISCO BATTUTA GOMMINI FRIZ. 2T/4T F.7 MM PER VITI 49727	
22	49727	8	VITE PARASTRAPPI K9 M7X1X12.5	SCREW, M7X1X12,5 K9 ENGINE
23	F25254	1	CAMPANA FRIZ. ALTA 4T	CLUTCH BASKET 450/530/600 HIGH
24	21005	8	GOMMINO PARASTRAPPI FRIZIONE	RUBBER, CLUTCH BASKET
25	40249	1	COPPIA PRIM. 250 2/4T Z57	PRIMARY GEAR 57T, 250 2T
26	19050	2	GABBIA COPPIA FRIZIONE 250	NEEDLE CAGE CLUTCH 250cc
27	26252	1	DISTANZ.GABBIA COPPIA FRIZ.250	SPACER, NEEDLE CAGE CLUTCH 250
28	49474	1	VITE TCEI 5X16 UNI 5931	BOLT TCEI 5X16



4T450FIMX22-M
MOTORE - ENGINE

FRIZIONE
CLUTCH

29	F30029	1	COP. FRIZ/IDR 450/530 2015 CPL	COVER IDR. CLUTCH 450/530 M.15
30	F19517	1	SFERA X PIST.FRIZ.IDRAUL.250N	BALL IDR. CLUTCH PISTON 250N
31	F30976	1	COP. FRIZ/IDR NUDO	
32	35264	1	VITE SPURGO OLIO FRIZ.IDR.6X1	SCREW AIR BLED HYDRAUL.CLUTCH
33	12252	1	O RING PIGNONE CAT.+DIS.AL.MOT	O-RING, 25,12 x 1,78
34	F16470	1	MOLLA CONTR. PIST/FRI 450Fi'15	
35	12259	1	O RING PISTONE FR.125/250VERDE	O-RING, CLUTCH PISTON 125/250
36	F35554	1	PISTONCINO POMPA FRIZIONE	PISTON CLUTCH MASTER CYLINDER
37	49535	2	VITE TCEI 5X35 UNI 5931	BOLT TCEI 5X35
38	26211	2	BOCCOLA PROT. PIGNONE 250 F.5	COLLAR, SPROCKET 250cc H.5
39	40029	1	PROTEZIONE PIGNONE 09/-> PLAST	PROTECTION FRONT SPROCKET09/13
40	40022	1	PROTEZIONE ERGAL PIGNONE CAT.	PROTECTION, GEAR CHAIN ERGAL
41	35050	1	RONDELLA X FRIZ. 250/300/4T	CLUCTH WASHER 250/300/F



4T450FIMX22-M
MOTORE - ENGINE

COMANDO CAMBIO
GEARSHIFT MECHANISM

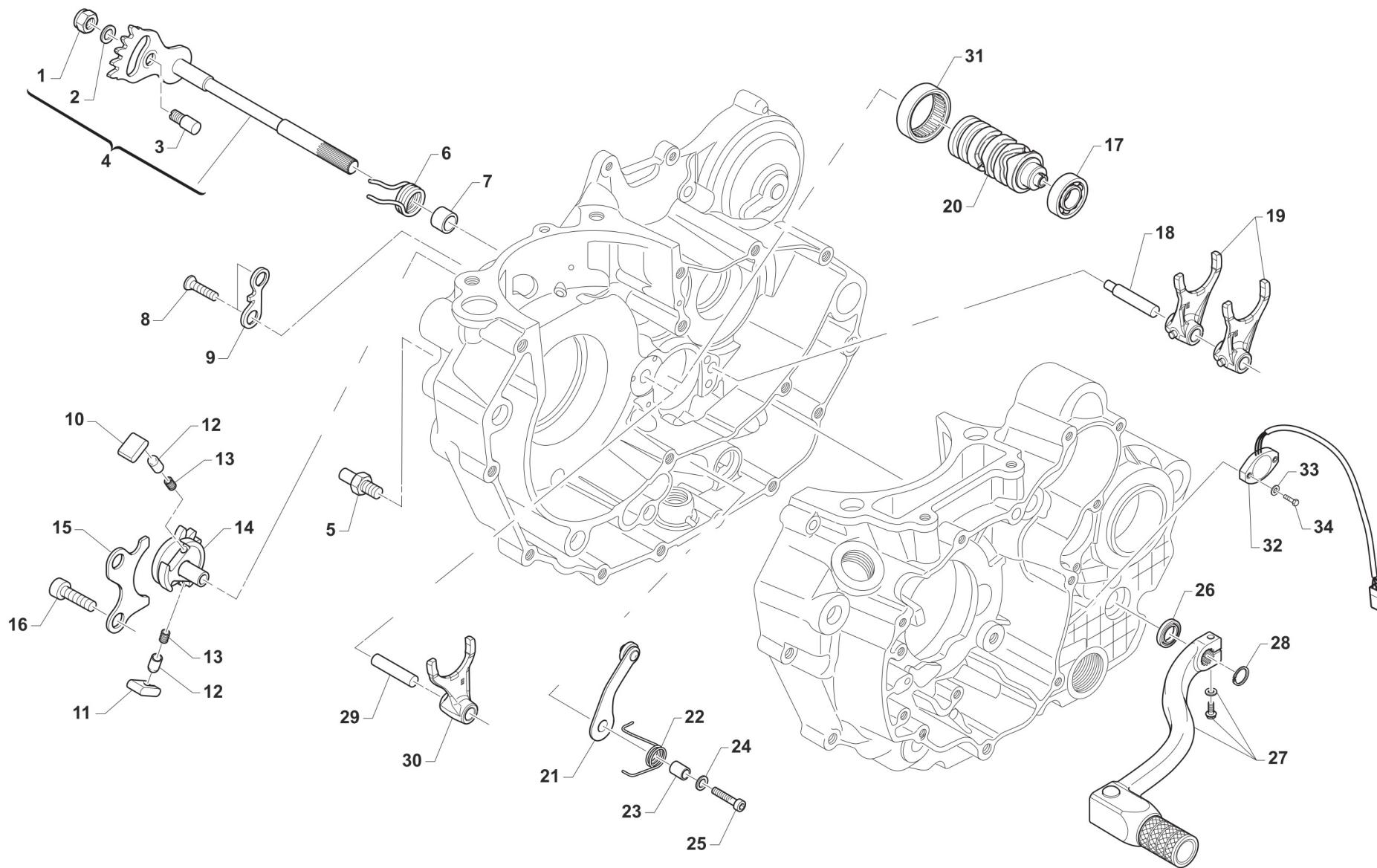

TM0136



4T450FIMX22-M
MOTORE - ENGINE

COMANDO CAMBIO
GEARSHIFT MECHANISM

1	49638	1	DADO M 6 ALTO AUTOBLOCCANTE	NUT 6mm, HIGHT SELF-LOCKING
2	49603	1	RONDELLA M 6,4 X 12 X 1,6	WASHER 6x12
3	26050	1	BATTUTA ECCENTRICA	ADJUSTER SELECTOR SHAFT
4	28100	1	ALBERO COMANDO ING. P.TACRIC.	SHAFT, GEARSHIFT
5	26051	1	BATTUTA FISSA LEVA CAMBIO INT.	PLATE INT. END STROKE GEAR LEVER
6	16009	1	MOLLA RITORNO LEVA CAMBIO 32CR	SPRING, RETURN GEAR LEVER 3,2
7	26006	1	DISTANZIALE MOLLA LEVA CAMBIO	SPACER, GEAR LEVER SPRING
8	49405	2	VITE TSEI 6X20 UMB.5933 10.9	BOLT TSEI 6x20 U.5933 10.9
9	26022	1	PIASTRINO FINE CORSA	PLATE END STROKE GEAR LEVER
10	26060	1	CRICCHETTO CAMBIO SUPERIORE	RATCHET UP, GEAR
11	26061	1	CRICCHETTO CAMBIO INFERIORE	RATCHET DOWN, GEAR
12	26062	2	PUNTALE PER CRICCHETTO CAMBIO	PIN, RATCHET GEAR
13	16012	2	MOLLA PER PUNTALE	SPRING, GEARBOX PIN
14	40310	1	INGRANAGGIO PORTACRICCHETTI	DRUM SHIFTER GEAR
15	26021	1	PIASTRINO RIENTRO CRICCHETTI	PLATE, RATCHET
16	49483	2	VITE TCEI 6X16 UNI 5931	BOLT TCEI 6X16
17	03012	1	CUSCINETTO DESMODROMICO 6001 2RS	BUSH, 6001 2RS GEAR DRUM
18	33256	1	PERNO FORCH.ALB.SEC. 250 / 125.99	AXEL, COUNTERSHAFT FORK 250cc
19	F33314	2	FORCHETTA A/S 125/250/300 CROM	SHIFT FORK SECONDARY 125/250CR
20	F33327	1	ALBERO DESMO INTEGRALE 5M SENS/CA	
21	F26479	1	PIASTRINO BLOCCA MAR. 250Fi 12	PLATE, STOP GEAR 250 4S 12->
22	F16447	1	NON UTILIZZARE !!! MOLLA BLOCCA MARCE 250Nsostituita da F16447.3	SPRING, STOP GEAR 250 4S
23	26007	1	DISTANZIALE MOLLA BLOCCAMARCE	SPACER, STOP GEAR SPRING
24	49604	1	RONDELLA 6 X18 X 1,6	WASHER 6x18
25	49485	1	VITE TCEI 6X25 UNI 5931	BOLT TCEI 6x25
26	04004	1	PARAOLIO POMPA H2O-LEVA CAMBIO	OIL SEAL 12 x 22 x 5
27	43048	1	LEVA CAMBIO 2014 + 12MM (253) 85/125/144 2T 250Fi	GEAR LEVER 2014 +12mm
28	49212	1	SEEGER E12 LEVA CAMBIO	CIRCLIP D.12 - EXTERNAL



4T450FIMX22-M
MOTORE - ENGINE

COMANDO CAMBIO
GEARSHIFT MECHANISM

29	33255	1	PERNO FORCH.ALB. PRIM.250 / 125.99	AXEL, MAINSHAFT FORK 250cc
30	F33313	1	FORCHETTA A/P 2T 250/300 CROM.	SHIFT FORK PRIM.250/300cc CROM
31	19041	1	ASTUCCIO A RULLI DHK 35/12	BUSH NEEDLE CAGE DHK 35/12
32	F08236.1	1	SENSORE POSIZ.CAMBIO RFD-4021 CABLATO	SENSOR GEAR POSITION RFD-4021 W/WIRE
33	49926	2	RONDELLA 3X9X1	WASHER 3 X 9 X 1
34	49922	2	VITE TE 3X14	

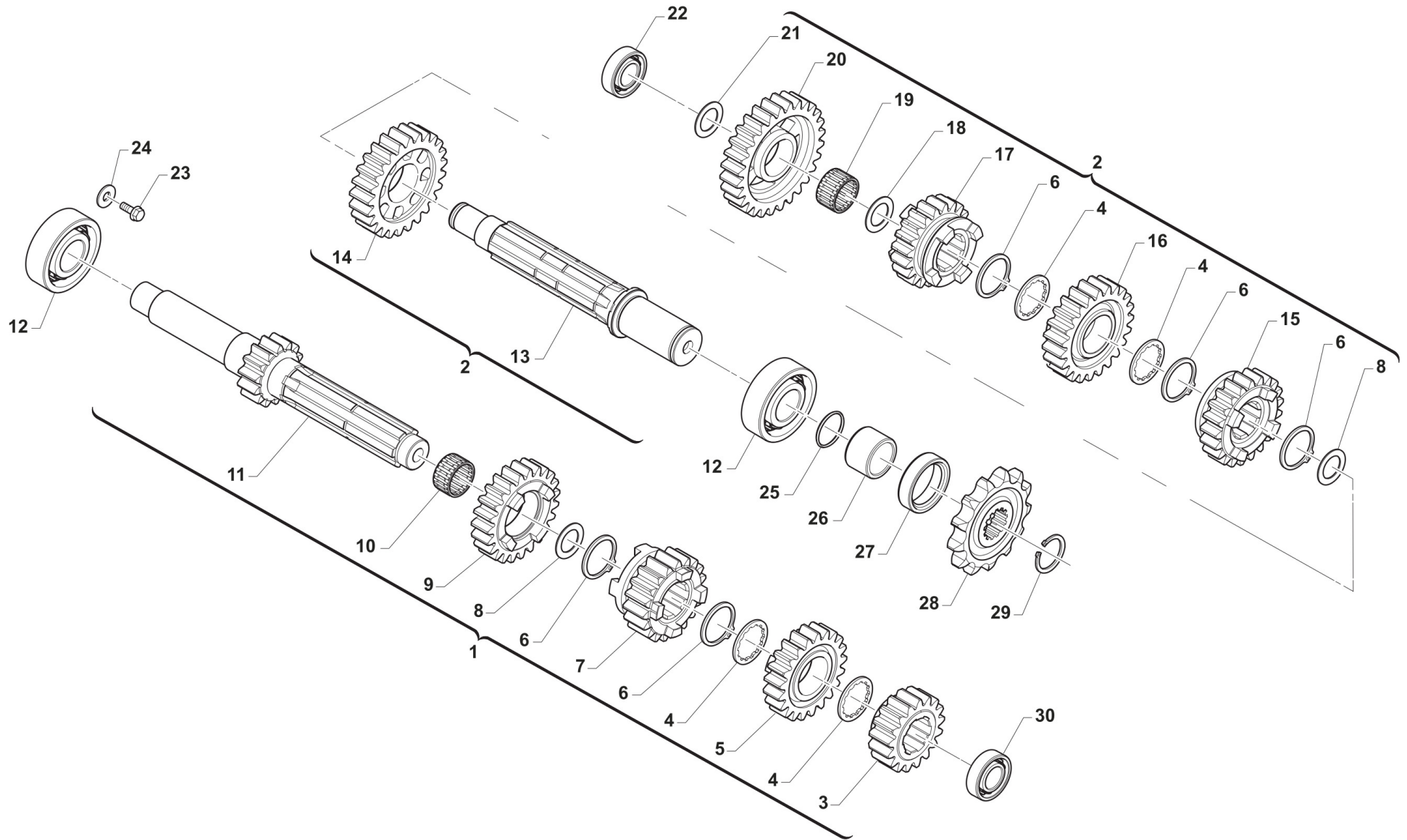



4T450FIMX22-M
MOTORE - ENGINE

CAMBIO
GEAR BOX

1	F40934.1	1	ALBERO PRIM. CPL 450/530 MX	
2	F40935.1	1	ALBERO SEC. CPL 450/530 MX	
3	F40877	1	INGRAN A.P. 2a Z 17 X Z24	GEAR, 2TH (17T) for (24T)
4	48251	4	SPESSORE DENT.CAMBIO 250/KZ10B	SPACER, GEAR 250cc
5	40260	1	INGRAN A.P. 4a Z 21 250 CR/E	GEAR, 4TH (21T) MAINSHAFT MX/E
6	49255	5	SEEGER RETTIFICATO CAMBIO 250	CIRCLIP, GEAR BOX 250cc
7	F40906	1	INGRAN A.P. 3a Z 16	GEAR, 3RD (16T) MAINSHAFT
8	48254	2	SPE.SRE CAMBIO 25.2X31.8X1 250	SPACER,GEAR BOX250 25.2X31.8X1
9	40262	1	INGRAN A.P. 5a Z 23 250/CROSS	GEAR, 5TH (23T) MAINSHAFT MX
10	19051	1	GABBIA ING. V AP. 250	NEEDLE CAGE K 25x29x10 AP250
11	F40873	1	ALBERO PRIMARIO Z16	MAINSHAFT 16T (4 Stroke)
12	03252	2	CUSCINETTO 6205 C4 A/P 250/K9	BUSH, MAINSHAFT 250 / KZ
13	40270	1	ALBERO SECONDARIO 250/450	COUNTERSHAFT 250cc
14	F40878	1	INGRAN A.S. 2a Z 24 2V	GEAR, 2ND (24T) COUNTERSHAFT
15	40279	1	INGRAN A.S. 4a Z 21 250 CR/E	GEAR, 4TH(21T)COUNTER.MX/E 250
16	F40907	1	INGRAN A.S. 3a Z 19	GEAR, 3RD (19T) COUNTERSHAFT
17	40281	1	INGRAN A.S. 5a Z 20 250/CROSS	GEAR, 5TH(20T)COUNTERSH.MX 250
18	48252	1	SPESSORE CAMBIO 20X29X1 250	SPACER, GEAR 250 20X29X1
19	19012	1	GABBIA A RULLI K 20X24X10	BUSH NEEDLE CAGE 20 X 24 X 10
20	F40874	1	INGRAN A.S. 1a Z 27 X A.P.Z16	GEAR, 1ST (27T) COUNTERSHAFT
21	48253	1	SPESSORE CAMBIO 17X30X1 250	SPACER, GEAR BOX 250cc 17X30X1
22	03251	1	CUSCINETTO 6203/C3 A/P A/S 250	BUSH, MAINSHAFT COUNTER.250/4T
23	49480	1	VITE TCEI 6X10 UNI 5931	BOLT TCEI 6X10
24	49604	1	RONDELLA 6 X18 X 1,6	WASHER 6x18
25	12252	1	O RING PIGNONE CAT.+DIS.AL.MOT	O-RING, 25,12 x 1,78
26	26255	1	DISTANZIALE PIGNONE CAT.250 04	SPACER, SPROCKET DRIVE 250 04
27	04101	1	PARAOLIO PIGNONE CATENA 250	OIL SEAL 40 x 30 x 7
28	40212	1	PIGNONE CATENA Z12 250	SPROCKET 12T, DRIVE 250/300/4T



4T450FIMX22-M
MOTORE - ENGINE

CAMBIO
GEAR BOX

28	40214	1	PIGNONE CATENA Z13 250/2T e 4T	SPROCKET 13T, DRIVE 250/300/4T
28	F40925	1	PIGNONE CATENA Z14 O/S 2MM	SPROCKET 14T, DRIVE 4S O/S 2mm
29	49252	1	SEEGER PIGNONE CATENA 250 E 25	CIRCLIP D.25 FRONT SPROKET 250
30	03254	1	CUSCINETTO A.P.4 Tempi 2RS1/C3	BUSH, MAINSHAFT 2RS/C3 4S

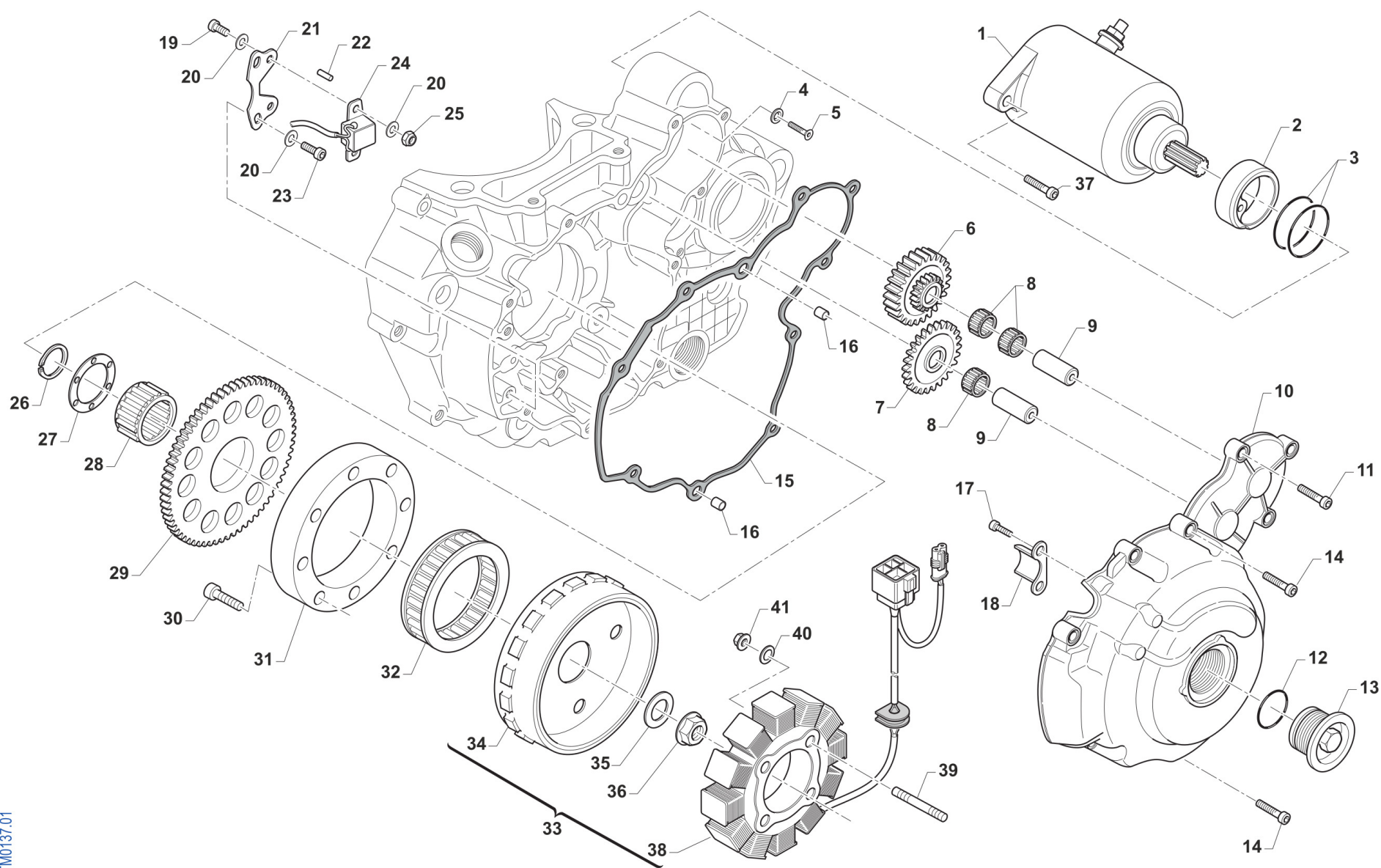

TM0137.01



4T450FIMX22-M
MOTORE - ENGINE

ACCESNIONE ES

1	F68100	1	MOTORINO AVVIAMENTO 4T SM14233	E-STARTER ENGINE ASSY 4 S
2	F26341	1	BOCCOLA CENTRAGGIO MOT.AVVIAM.	COLLAR, EL. STARTER
3	F12309	2	O RING 2150	O-RING, 2150
4	49675	1	RONDELLA 7	
5	49399	1	VITE TSEI 5X12	BOLT TSEI 5x12
6	F40839	1	INGRANAGGIO DOPPIO RINF. E.S.	GEAR, ELECT. START
7	F40808	1	INGR. FOLLE AVVIAMENTO EL.	INTERMEDIATE GEAR
8	F19501	3	GABBIA A RULLI 10X13X10 4T	NEEDLE CAGE 10X13X10 F.S.
9	F28568	2	ALBERINO LUNGO ING. AVV.ELETRR	SHAFT, EL. STARTER GEAR
10	F30948	1	COP. ACC. 450Fi MX/SMX ES	COVER, IGNITION 450Fi MX/SM ES
11	49476	8	VITE TCEI 5X20 UNI 5931	BOLT TCEI 5X20
12	F12322	1	O RING 2106	O-RING
13	F49833	1	TAPPO COPERCHIO ACC.250Fi	COVER CAP ALUMINIUM 250Fi
14	49477	2	VITE TCEI 5X25 UNI 5931	BOLT TCEI 5X25
15	F05823	1	GUARNIZIONE COP.STATORE E.S.PF	GASKET, IGNITION COVER ES PF
16	26041	2	GRANO CENTRAGGIO D.7X8 F.5,2	DOWEL PIN 7 x 8 Hole 5,2
17	49593	2	VITE TCEI 4X8 U.	BOLT TCEI 4X8 U.
18	F30708	1	PROTEZIONE CAVI ACCENSIONE	
19	49435	2	VITE TE 5X12	SCREW TE 5X12
20	49678	6	RONDELLA 5 x 10 x 1	
21	F15554	1	PIASTRINO SUPPURTO PICKUP DOPPIO FORO	
22	F19504	1	RULLO D.4 X 8	PIN D.4 X 8
23	49474	2	VITE TCEI 5X16 UNI 5931	BOLT TCEI 5X16
24	F15478	1	PICK-UP KOKUSAN	PICK-UP KOK PU5157
25	49633	2	DADO M 5 BASSO AUTOBLOCCANTE	NUT 5mm, LOW SELF-LOCKING
26	F49937	1	SEEGER ALBERO E 36 4T	CIRCLIP 36 CRANKSH. E 4S
27	F26327	1	RONDELLA ACC. 37X53X2 4T	WASHER 37X50X2 4S.
28	F19506	1	GABBIA A RULLI AVV.EL.37X42X17	NEEDLE CAGE 37X42X17 E.S.



4T450FIMX22-M
MOTORE - ENGINE

ACCESNIONE ES

11

29	F40807	1	INGR. CONDOTTO AVVIAMENTO EL.	GEAR EL. STARTER
30	F49929	8	VITE TCE BASSA 6X16 (CL. 12.9)	SCREW TCE 6 X 16
31	F26385	1	ANELLO ESTERNO PESANTE R.L.KOK	EXTERNAL RING IGNITION KOKUSAN
32	F03354	1	RUOTA LIBERA MOTORINO AVV. 4T	FREE-WHEEL ELECTRIC STARTER
33	F15561	1	GENERATORE KOKUSAN MX E.S. KOK / SUMIT. 2V	GENERATOR KOKUSAN MX E.S.
34	F15549	1	ROTORE KOKUSAN YF9019	ROTOR, KOKUSAN YF9019
35	49613	1	RONDELLA ACCIAIO 12	STEEL WASHER 12
36	49056	1	DADO ACCENS 100/TAG/KZ 125MX/E	NUT, IGNITION 100cc
37	49484	2	VITE TCEI 6X20	BOLT TCEI 6X20
38	F15547	1	STATORE KOKUSAN YS 9018 C. KOK / SUM	
39	F49836	4	PRIGIONIERO M5/M4 STATORE KOK.	
40	49686.2	4	RONDELLA ZIGRINATA 4 X 0,50 (ACCENSIONE 4T)	
41	49631	4	DADO M 4 BASSO AUTOBLOCCANTE	NUT 4mm, LOW SELF-LOCKING



4T450FIMX22-M
MOTORE - ENGINE

-

03012	4T450FIAA15-M-08	17	1
03251	4T450FIMX15-M-09	22	1
03252	4T450FIMX15-M-09	12	2
03254	4T450FIMX15-M-09	30	1
04004	4T450FIAA15-M-08	26	1
04017	4T450FIXK22-M-05	9	1
04036	4T450FIMX22-M-01	33	1
04101	4T450FIMX15-M-09	27	1
09006	4T450FIAA15-M-07	9	1
12012	4T450FIMX22-M-03	23	2
12029	4T450FIXK22-M-05	53	1
12094	4T450FIXK22-M-05	19	1
12252	4T450FIAA15-M-07	33	1
	4T450FIMX15-M-09	25	1
12259	4T450FIAA15-M-07	35	1
16009	4T450FIAA15-M-08	6	1
16012	4T450FIAA15-M-08	13	2
19012	4T450FIMX15-M-09	19	1
19021	4T450FIXK22-M-05	27	2
19022	4T450FIAA15-M-07	10	1
19023	4T450FIAA15-M-07	11	1
19041	4T450FIAA15-M-08	31	1
19050	4T450FIAA15-M-07	26	2

19051	4T450FIMX15-M-09	10	1
21005	4T450FIAA15-M-07	24	8
25253	4T450FIAA15-M-07	8	1
26006	4T450FIAA15-M-08	7	1
26007	4T450FIAA15-M-08	23	1
26021	4T450FIAA15-M-08	15	1
26022	4T450FIAA15-M-08	9	1
26041	4T450FIAX12-M-11	16	2
	4T450FIMX22-M-02	19	2
	4T450FIXK22-M-05	45	1
26050	4T450FIAA15-M-08	3	1
26051	4T450FIAA15-M-08	5	1
26060	4T450FIAA15-M-08	10	1
26061	4T450FIAA15-M-08	11	1
26062	4T450FIAA15-M-08	12	2
26211	4T450FIAA15-M-07	38	2
26252	4T450FIAA15-M-07	27	1
26255	4T450FIMX15-M-09	26	1
28100	4T450FIAA15-M-08	4	1
33255	4T450FIAA15-M-08	29	1
33256	4T450FIAA15-M-08	18	1
35050	4T450FIAA15-M-07	41	1
35250	4T450FIAA15-M-07	14	6
35254	4T450FIAA15-M-07	15	2
35262.1	4T450FIAA15-M-07	21	1
35264	4T450FIAA15-M-07	32	1

40022	4T450FIAA15-M-07	40	1
40029	4T450FIAA15-M-07	39	1
40212	4T450FIMX15-M-09	28	1
40214	4T450FIMX15-M-09	28	1
40248	4T450FIMX22-M-04	17	1
40249	4T450FIAA15-M-07	25	1
40260	4T450FIMX15-M-09	5	1
40262	4T450FIMX15-M-09	9	1
40270	4T450FIMX15-M-09	13	1
40279	4T450FIMX15-M-09	15	1
40281	4T450FIMX15-M-09	17	1
40310	4T450FIAA15-M-08	14	1
43048	4T450FIAA15-M-08	27	1
48250	4T450FIAA15-M-07	17	2
48251	4T450FIMX15-M-09	4	4
48252	4T450FIMX15-M-09	18	1
48253	4T450FIMX15-M-09	21	1
48254	4T450FIMX15-M-09	8	2
49012	4T450FIMX22-M-04	12	1
49056	4T450FIAX12-M-11	36	1



4T450FIMX22-M
MOTORE - ENGINE

-

	4T450FIMX22-M-04	14	1
49060	4T450FIAA15-M-07	16	1
49104	4T450FIXK22-M-05	4	1
49212	4T450FIAA15-M-08	28	1
49216	4T450FIXK22-M-05	54	1
49252	4T450FIMX15-M-09	29	1
49255	4T450FIMX15-M-09	6	5
49355	4T450FIAA15-M-07	5	6
49399	4T450FIAX12-M-11	5	1
	4T450FIMX22-M-01	7	1
	4T450FIMX22-M-03	29	1
49405	4T450FIAA15-M-08	8	2
49407	4T450FIMX22-M-03	24	1
49429	4T450FIXK22-M-05	25	1
49435	4T450FIAX12-M-11	19	2
49474	4T450FIAA15-M-07	28	1
	4T450FIAX12-M-11	23	2
49476	4T450FIAX12-M-11	11	8
	4T450FIMX22-M-03	39	4
	4T450FIXK22-M-05	3	4
49477	4T450FIAA15-M-07	2	6
	4T450FIAX12-M-11	14	2
	4T450FIMX22-M-03	40	2

49480	4T450FIMX15-M-09	23	1
	4T450FIXK22-M-05	50	1
49483	4T450FIAA15-M-08	16	2
49484	4T450FIAX12-M-11	37	2
49485	4T450FIAA15-M-08	25	1
	4T450FIMX22-M-03	21	2
	4T450FIXK22-M-05	10	1
49486	4T450FIMX22-M-02	15	4
	4T450FIXK22-M-05	11	9
49487	4T450FIMX22-M-02	16	4
	4T450FIXK22-M-05	37	1
49488	4T450FIXK22-M-05	31	1
49535	4T450FIAA15-M-07	37	2
49570	4T450FIXK22-M-05	1	1
49576	4T450FIAA15-M-07	1	1
49578	4T450FIXK22-M-05	2	1
49593	4T450FIAX12-M-11	17	2
49603	4T450FIAA15-M-08	2	1
	4T450FIMX22-M-03	28	1
	4T450FIXK22-M-05	8	1
49604	4T450FIAA15-M-07	6	6
	4T450FIAA15-M-08	24	1
	4T450FIMX15-M-09	24	1
	4T450FIMX22-M-01	8	1

49613	4T450FIAX12-M-11	35	1
	4T450FIMX22-M-04	15	1
49631	4T450FIAX12-M-11	41	4
49633	4T450FIAX12-M-11	25	2
49638	4T450FIAA15-M-08	1	1
49640.85	4T450FIMX22-M-01	22	2
49675	4T450FIAX12-M-11	4	1
49676	4T450FIMX22-M-01	2	2
49678	4T450FIAX12-M-11	20	6
49681	4T450FIMX22-M-01	1	4
49686.2	4T450FIAX12-M-11	40	4
49702	4T450FIMX22-M-02	21	7
	4T450FIXK22-M-05	51	1
49711	4T450FIXK22-M-05	49	1
49727	4T450FIAA15-M-07	22	8
49922	4T450FIAA15-M-08	34	2
49926	4T450FIAA15-M-08	33	2
51069	4T450FIMX22-M-02	17	2
51073	4T450FIMX22-M-03	4	1
F01710	4T450FIMX22-M-01	23	1
F02890.1	4T450FIMX22-M-02	30	1
F02890.4	4T450FIMX22-M-02	31	1



4T450FIMX22-M MOTORE - ENGINE

-

F03350	4T450FIXK22-M-05	24	1
F03351	4T450FIXK22-M-05	21	1
F03352	4T450FIMX22-M-04	13	2
F03354	4T450FIAX12-M-11	32	1
F03363	4T450FIMX22-M-03	13	2
F03371	4T450FIMX22-M-03	37	2
F03376	4T450FIMX22-M-04	6	2
F04352	4T450FIXK22-M-05	13	1
F04354	4T450FIXK22-M-05	44	1
F04355	4T450FIMX22-M-01	14	1
F04356	4T450FIMX22-M-02	6	4
F04361	4T450FIMX22-M-03	5	1
F05820	4T450FIAA15-M-07	4	1
F05821	4T450FIXK22-M-05	16	1
F05822	4T450FIXK22-M-05	6	1
F05823	4T450FIAX12-M-11	15	1
F05830.450K	4T450FIMX22-M-01	24	1
F05843.1	4T450FIMX22-M-01	21	1
F05843.2	4T450FIMX22-M-01	21	1
F05843.3	4T450FIMX22-M-01	21	1
F05843.4	4T450FIMX22-M-01	21	1

F05865	4T450FIMX22-M-01	5	1
F06116	4T450FIMX22-M-02	14	1
F08003	4T450FIMX22-M-02	20	1
F08236.1	4T450FIAA15-M-08	32	1
F09393.1	4T450FIMX22-M-04	3	1
F09395	4T450FIMX22-M-04	4	2
F10871.94	4T450FIMX22-M-04	1	1
F10871.95	4T450FIMX22-M-04	1	1
F10871.96	4T450FIMX22-M-04	1	1
F11389	4T450FIMX22-M-04	2	1
F12301	4T450FIMX22-M-01	11	2
F12302	4T450FIMX22-M-01	10	1
	4T450FIXK22-M-05	17	1
F12307	4T450FIMX22-M-03	2	2
F12309	4T450FIAX12-M-11	3	2
F12311	4T450FIMX22-M-01	30	1
F12312	4T450FIMX22-M-01	29	1
F12322	4T450FIAX12-M-11	12	1
F13255	4T450FIMX22-M-02	18	1

F14121	4T450FIMX22-M-02	2	8
F14154	4T450FIMX22-M-02	12	2
F14160	4T450FIMX22-M-02	10	2
F15478	4T450FIAX12-M-11	24	1
F15547	4T450FIAX12-M-11	38	1
F15549	4T450FIAX12-M-11	34	1
F15554	4T450FIAX12-M-11	21	1
F15561	4T450FIAX12-M-11	33	1
F16435	4T450FIMX22-M-03	11	1
F16447	4T450FIAA15-M-08	22	1
F16453	4T450FIAA15-M-07	7	6
F16470	4T450FIAA15-M-07	34	1
F16472	4T450FIMX22-M-02	29	2
F16473	4T450FIMX22-M-02	4	2
F18058	4T450FIMX22-M-04	8	1
F18060	4T450FIMX22-M-04	7	1
F18130	4T450FIMX22-M-04	5	1
F18131	4T450FIMX22-M-04	9	1
F18131.1	4T450FIMX22-M-04	10	1
F19500	4T450FIXK22-M-05	35	3
F19501	4T450FIAX12-M-11	8	3



4T450FIMX22-M
MOTORE - ENGINE

-

	4T450FIXK22-M-05	30	1
F19504	4T450FIAX12-M-11	22	1
F19506	4T450FIAX12-M-11	28	1
F19517	4T450FIAA15-M-07	30	1
F21421	4T450FIMX22-M-02	13	1
F25254	4T450FIAA15-M-07	23	1
F25255	4T450FIAA15-M-07	18	1
F26301	4T450FIMX22-M-01	25	4
F26303	4T450FIXK22-M-05	33	1
F26304	4T450FIXK22-M-05	15	2
F26315	4T450FIMX22-M-04	16	1
F26327	4T450FIAX12-M-11	27	1
F26337.270	4T450FIMX22-M-02	1	1
F26337.275	4T450FIMX22-M-02	1	1
F26337.280	4T450FIMX22-M-02	1	1
F26337.285	4T450FIMX22-M-02	1	1
F26337.290	4T450FIMX22-M-02	1	1
F26337.295	4T450FIMX22-M-02	1	1
F26337.300	4T450FIMX22-M-02	1	1
F26337.305	4T450FIMX22-M-02	1	1
F26337.310	4T450FIMX22-M-02	1	1

F26337.315	4T450FIMX22-M-02	1	1
F26337.320	4T450FIMX22-M-02	1	1
F26337.325	4T450FIMX22-M-02	1	1
F26337.330	4T450FIMX22-M-02	1	1
F26337.335	4T450FIMX22-M-02	1	1
F26337.340	4T450FIMX22-M-02	1	1
F26341	4T450FIAX12-M-11	2	1
F26372	4T450FIMX22-M-02	11	2
F26373	4T450FIMX22-M-02	9	2
F26385	4T450FIAX12-M-11	31	1
F26403	4T450FIMX22-M-01	26	1
F26428	4T450FIMX22-M-01	15	3
F26433	4T450FIMX22-M-03	30	2
F26435	4T450FIMX22-M-03	10	1
F26469	4T450FIMX22-M-02	27	2
F26470	4T450FIMX22-M-02	7	2
F26479	4T450FIAA15-M-08	21	1
F26508	4T450FIMX22-M-03	14	1

F26509	4T450FIMX22-M-03	12	1
F26701	4T450FIMX22-M-02	3	4
F26723	4T450FIMX22-M-02	28	2
F26724	4T450FIMX22-M-02	5	2
F26745	4T450FIXK22-M-05	52	1
F28501	4T450FIXK22-M-05	29	1
F28533	4T450FIXK22-M-05	36	1
F28568	4T450FIAX12-M-11	9	2
F28660	4T450FIXK22-M-05	23	1
F28661	4T450FIXK22-M-05	7	1
F28692	4T450FIMX22-M-02	23	2
F28711	4T450FIMX22-M-02	24	4
F28723	4T450FIMX22-M-03	16	1
F28872	4T450FIMX22-M-03	9	1
F28874	4T450FIMX22-M-03	7	1
F28875	4T450FIMX22-M-03	15	1
F30008	4T450FIMX22-M-03	1	1
F30029	4T450FIAA15-M-07	29	1
F30031	4T450FIMX22-M-01	18	1
F30706	4T450FIXK22-M-05	38	1
F30708	4T450FIAX12-M-11	18	1



4T450FIMX22-M
MOTORE - ENGINE

-

F30795	4T450FIAA15-M-07	3	1
F30796	4T450FIXK22-M-05	5	1
F30832	4T450FIMX22-M-03	3	3
F30868	4T450FIMX22-M-03	6	1
F30948	4T450FIAX12-M-11	10	1
F30965	4T450FIXK22-M-05	18	1
F30976	4T450FIAA15-M-07	31	1
F30979	4T450FIXK22-M-05	12	1
F32500	4T450FIXK22-M-05	39	1
F32501	4T450FIXK22-M-05	43	1
F32502	4T450FIXK22-M-05	42	1
F32503	4T450FIXK22-M-05	41	1
F32506	4T450FIMX22-M-01	9	1
F32508.450	4T450FIXK22-M-05	32	1
F32511	4T450FIMX22-M-01	32	1
F32512	4T450FIMX22-M-01	31	1
F32513	4T450FIXK22-M-05	47	1
F32514	4T450FIXK22-M-05	46	1
F32515	4T450FIMX22-M-01	12	1
F32534	4T450FIMX22-M-03	38	1
F33313	4T450FIAA15-M-08	30	1
F33314	4T450FIAA15-M-08	19	2
F33327	4T450FIAA15-M-08	20	1
F35554	4T450FIAA15-M-07	36	1

F35567	4T450FIAA15-M-07	13	9
F35578	4T450FIAA15-M-07	19	1
F35582	4T450FIAA15-M-07	12	1
F40801	4T450FIXK22-M-05	34	1
F40802	4T450FIXK22-M-05	28	1
F40807	4T450FIAX12-M-11	29	1
F40808	4T450FIAX12-M-11	7	1
F40839	4T450FIAX12-M-11	6	1
F40873	4T450FIMX15-M-09	11	1
F40874	4T450FIMX15-M-09	20	1
F40877	4T450FIMX15-M-09	3	1
F40878	4T450FIMX15-M-09	14	1
F40906	4T450FIMX15-M-09	7	1
F40907	4T450FIMX15-M-09	16	1
F40925	4T450FIMX15-M-09	28	1
F40934.1	4T450FIMX15-M-09	1	1
F40935.1	4T450FIMX15-M-09	2	1
F40938	4T450FIAA15-M-07	20	1
F40950	4T450FIMX22-M-03	17	1
F40951	4T450FIMX22-M-03	8	1
F40973	4T450FIXK22-M-05	22	1

F49066	4T450FIMX22-M-02	22	1
F49823	4T450FIMX22-M-02	25	1
F49826	4T450FIMX22-M-03	25	1
F49833	4T450FIAX12-M-11	13	1
F49836	4T450FIAX12-M-11	39	4
F49853	4T450FIMX22-M-04	11	1
F49902	4T450FIXK22-M-05	48	1
F49903	4T450FIXK22-M-05	26	1
F49905.1	4T450FIMX22-M-01	17	1
F49910	4T450FIMX22-M-02	8	4
F49913	4T450FIXK22-M-05	14	1
F49915	4T450FIXK22-M-05	40	1
F49916	4T450FIMX22-M-04	19	1
F49917	4T450FIMX22-M-04	18	1
F49920	4T450FIMX22-M-01	19	1
F49922.1	4T450FIMX22-M-01	27	2
F49923	4T450FIMX22-M-01	13	1
F49925	4T450FIMX22-M-01	20	1
F49926	4T450FIMX22-M-01	3	1



4T450FIMX22-M
MOTORE - ENGINE

-

F49926.1	4T450FIMX22-M-01	4	1
F49929	4T450FIAX12-M-11	30	8
F49933	4T450FIMX22-M-01	16	1
F49937	4T450FIAX12-M-11	26	1
F49939	4T450FIMX22-M-02	26	2
F49972	4T450FIMX22-M-01	28	3
F49980	4T450FIMX22-M-01	6	4
F66510	4T450FIXK22-M-05	20	1
F68100	4T450FIAX12-M-11	1	1
F70309	4T450FIMX22-M-03	18	1
F70326.5	4T450FIMX22-M-03	20	1
F70345	4T450FIMX22-M-03	26	1
F70354	4T450FIMX22-M-03	22	1
F70380	4T450FIMX22-M-03	19	1
F70400	4T450FIMX22-M-03	27	1