



USES AND
RACOMMENDS



www.tmracing.it

TM Racing SpA - Via Fano, 6
61122 Pesaro - ITALY
Phone: +39 0721 25113

2T125FIEN21-M

**MOTORE
ENGINE**

21/02/2022



INFORMAZIONI GENERALI

Il presente catalogo serve per richiedere con esattezza le parti di ricambio.

Nelle ordinazioni indicare:

1) Il numero di matricola del Telaio che è stampigliato sul lato destro del canotto di sterzo. Nei modelli EN, SMR, SMR il numero di matricola è riportato anche su una targhetta posta sul lato sinistro (Vedi foto).

2) il numero di serie del Motore. E' posto sulla sinistra del motore tra la leva cambio e i coperchio accensione (Vedi foto).

3) Il codice dei particolari seguito dalla descrizione.

4) Il colore per i pezzi verniciati o comunque colorati.

Le indicazioni destra e sinistra si riferiscono ai lati del veicolo rispetto al senso di marcia.

Foto e disegni sono solo a scopo informativo e potrebbero non corrispondere esattamente alle caratteristiche dei prodotti.

GENERAL INFORMATION

The present spare parts catalogue enables one to order exactly the right spare part.

When ordering specify:

1) The frame serial number. It is embossed on the right side of the steering metal tube. In the EN, SMR and SMR models, the serial number is also stated on a plate positioned on the left hand side (See photo).

2) The engine serial numer. It is located on the left side of the engine between the gear lever and the ignition cover (See photo).

3) The part's code number followed but its description.

4) Indicate colour for painted or colored parts.

References to right and left apply to the vehicle in terms of its direction of movement.

Photos and drawings are for informational purposes only and may not exactly match the characteristics of the products.

NOTE – LEGENDA

MY

NOVITA' INTRODOTTA DIFFERENTE O NON PRESENTE NEL MODELLO DELL'ANNO PRECEDENTE

PART DIFFERENT OR NOT PRESENT IN THE REVIOUS YEAR MODEL

5M

MOTORE CON CAMBIO A 5 MARCE
ENGINE WITH 5 GEARS SPEED

6M

MOTORE CON CAMBIO A 6 MARCE
ENGINE WITH 6 GEARS SPEED

KS

MOTORE CON SOLO KICK STARTER
ENGINE WITH KICK STARTER ONLY

ES

MOTORE CON AVVIAMENTO ELETTRICO
ENGINE WITH ELECTRIC STARTER

X

RICAMBIO NON DISPONIBILE ALLA VENDITA
PART CAN NOT BE SOLD SEPARATELY



Le illustrazioni riportate in questo manuale sono fornite solo come riferimento e possono variare dal prodotto effettivo,

Dati indicativi soggetti a modifiche senza impegno di preavviso.

The illustrations in this manual are for reference only and may vary from the actual product.

All data are subject to modification without prior notice.



2T125FIEN21-M
MOTORE - ENGINE

CILINDRO - CYLINDER.....	4
SISTEMA INIEZIONE - INJECTION SYSTEM.....	7
MOTORINO VALVOLA - ELECTRIC VALVE SYSTEM.....	9
ALBERO MOTORE E PISTONE - CRANKSHAFT AND PISTON.....	11
ACCENSIONE - IGNITION.....	13
BASAMENTO E PACCO.....	15
FRIZIONE - CLUTCH.....	17
COPERCHI FRIZIONE - CLUTCH CASE.....	20
MESSA IN MOTO - KICK STARTER.....	22
COMANDO CAMBIO - GEARSHIFT MECHANISM.....	24
CAMBIO - GEAR BOX.....	27
-	30



2T125FIEN21-M
MOTORE - ENGINE

CILINDRO
CYLINDER

1

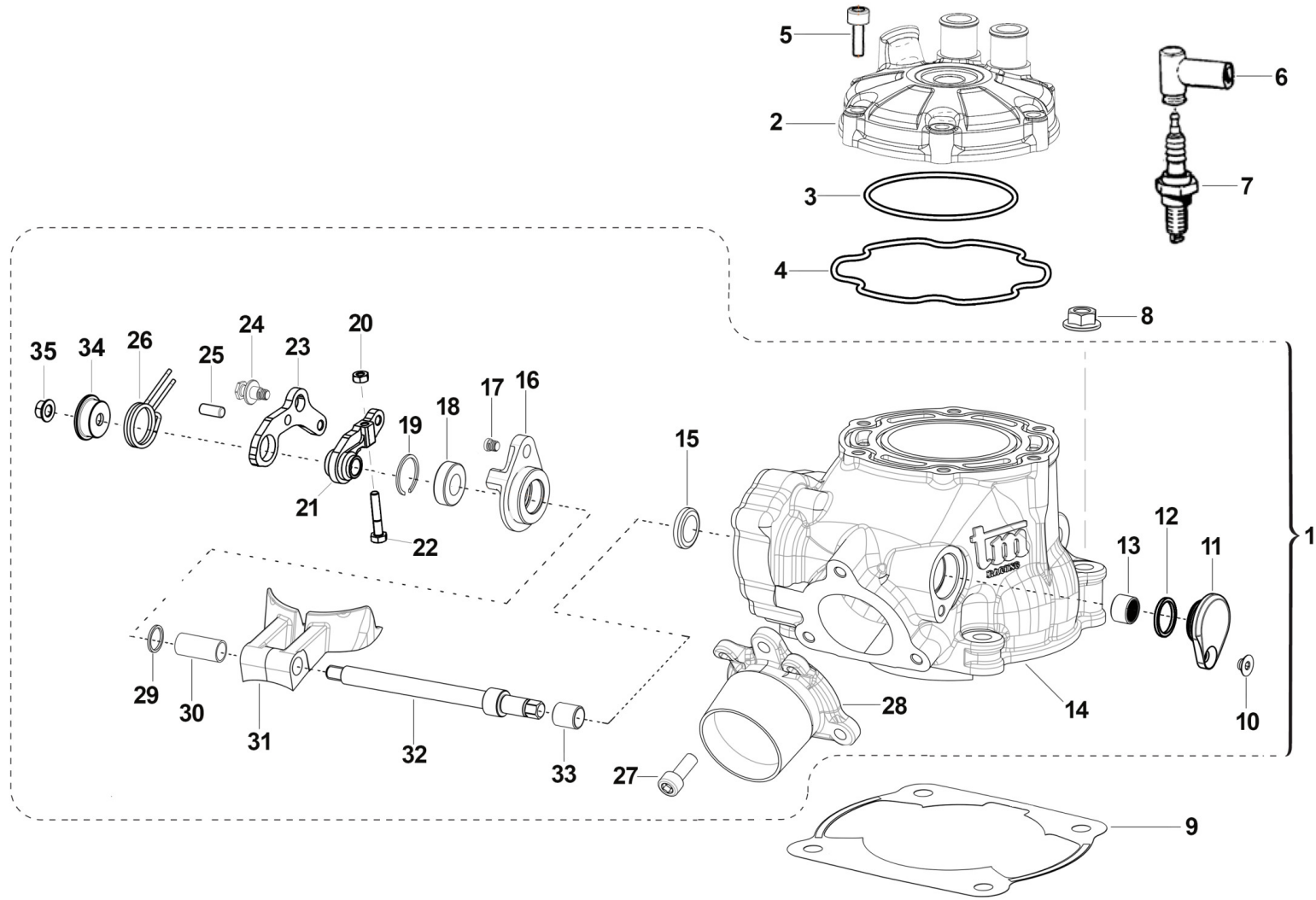

TM125FI20-001



**2T125FIEN21-M
MOTORE - ENGINE**

**CILINDRO
CYLINDER**

1	01135	1	MY20	CILINDRO 125Fi 2T EN/SMR CPL M2020	
2	02028	1		TESTA 125 2T FI END. MOD. 2020	
3	12003	1		O RING TESTA 125 90/06KVK8-910 NBR	O-RING, HEAD 125 90/06 KV8910
4	12021	1		O RING PREFORMATO CIL.125/12->	O-RING, HEAD 125EV M. 2012
5	49358	6		VITE TE F/R 6X30 Ch.8	BOLT 6X30 T.8
6	F21418	1		PIPETTA CANDELA NGK VD05FMH	CAP, NGK SPARK PLUG VD05FMH
7	F06105	1		CANDELA NGK CR9EIX CON/NIPPLO	SPARK PLUG NGK CR9EIX
8	49640	4		DADO M 8 FLANGIATO CHIAVE 12	NUT 8mm, FLANGE
9	05530	1		GUARN. B/CIL 125 M.2012 0,10	GASKET, CYL 125EV M.12/-> 0,10
9	05531	1		GUARN. B/CIL 125 M.2012 0,15	GASKET, CYL 125EV M.12/-> 0,15
9	05532	1		GUARN. B/CIL 125 M.2012 0,20	GASKET, CYL 125EV M.12/-> 0,20
9	05533	1		GUARN. B/CIL 125 M.2012 0,30	GASKET, CYL 125EV M.12/-> 0,30
9	05534	1		GUARN. B/CIL 125 M.2012 0,40	GASKET, CYL 125EV M.12/-> 0,40
9	05535	1		GUARN. B/CIL 125 M.2012 0,50	GASKET, CYL 125EV M.12/-> 0,50
10	49399	1		VITE TSEI 5X12	BOLT TSEI 5x12
11	30217	1		TAPPO SX ALB.COM.VALV.PAL.125	SIDE COVER
12	F12308	1		O RING 17,5 - 1,5	O-RING 17,5 - 1,5
13	19060	1		ASTUCCIO A RULLI HK 1212	NEEDLE CAGE HK 1212
14	01127	1	MY20	CILINDRO 125Fi 2T EN/SMR M2020 NUDO	
15	04115	1		PARAOLIO G 12X18X3	OIL SEAL 12x18x3
16	26258	1	MY20	FLANGIA PORTACUSC.ALB.VALV.250/300 IE	FLANGE, BEARING HOLDER
17	49757	1		VITE TBCE 5 X 12	BOLT TBCE 5X12
18	03156	1		CUSCINETTO V.SC.C.12 698LLU/5K	BUSH, EXHAUST VALVE 698LLU
19	49220	1		SEEGER INT.19	SEEGER I 19
20	49630	1	MY20	DADO M 4 (BASSO)	NUT 4mm, LOW
21	28108	1	MY20	LEVA INTERNA COMANDO VALVOLE EES-2 125/144 2020	LEVER, INTERNAL, VALVE
22	49874	1	MY20	VITE TE 4X16	BOLT TE 4X16
23	28263	1	MY20	LEVA ESTERNA COMANDO VALVOLE EES-2	LEVER, EXTERNAL, VALVE



2T125FIEN21-M
MOTORE - ENGINE

CILINDRO
CYLINDER

1

24	26168	1	MY20	PERNO MOLLA EES-2 16066	PIN, SPRING
25	F19536	1	MY20	RULLO D. 5 X 12 M6 DIN 6325	PIN 5X12
26	16066	1	MY20	MOLLA EES-2	SPRING EES-2
27	49355	3		VITE TE F/R 6X16 Ch.8	BOLT 6X16 T.8
28	13081	1		COLLETTORE SCA. 125 12/-> 3F	MANIFOLD EXHAUST 125cc 12->
29	26130.12	1		SPESS. REG. CIL.125 2012 1.2	SPACER CYL. 125 ->12 1.2
29	26130.13	1		SPESS. REG. CIL.125 2012 1.3	SPACER CYL. 125 ->12 1.3
29	26130.14	1		SPESS. REG. CIL.125 2012 1.4	SPACER CYL. 125 ->12 1.4
29	26130.15	1		SPESS. REG. CIL.125 2012 1.5	SPACER CYL. 125 ->12 1.5
29	26130.16	1		SPESS. REG. CIL.125 2012 1.6	SPACER CYL. 125 ->12 1.6
29	26130.17	1		SPESS. REG. CIL.125 2012 1.7	SPACER CYL. 125 ->12 1.7
29	26130.18	1		SPESS. REG. CIL.125 2012 1.8	SPACER CYL. 125 ->12 1.8
29	26130.19	1		SPESS. REG. CIL.125 2012 1.9	SPACER CYL. 125 ->12 1.9
30	26147	1	MY20	BOCCOLA DIST. CIL.250/300 2015	BUSH
31	22065.15	1		VALVOLE SCARICO 125 EV M.15/->	VALVES EXHAUST 125 2S EV 15->
32	28059	1		ALBERO COMANDO PALETTE 125	SHAFT, BOOSTER 125
33	19061	1		BOCCOLA IR 8X12X12.5	BUSH, IR 1X12X12,5
34	26167	1	MY20	PIATTELLO GUIDA MOLLA EES-2 16066	COLLAR, SPRING
35	49676	1	MY20	DADO M 6X1 FLANG. AUTOBL.ACC.	NUT, FLANGED M6 X 1 S.B.

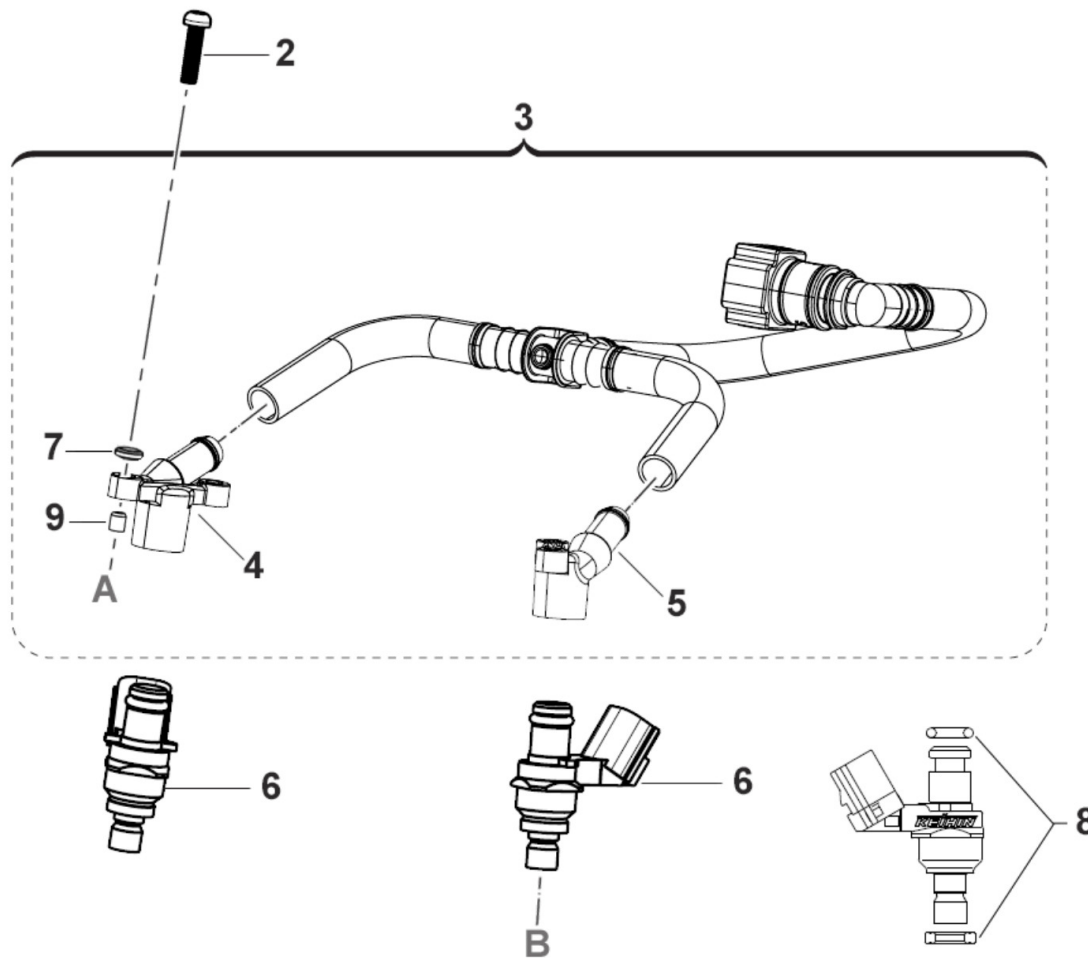
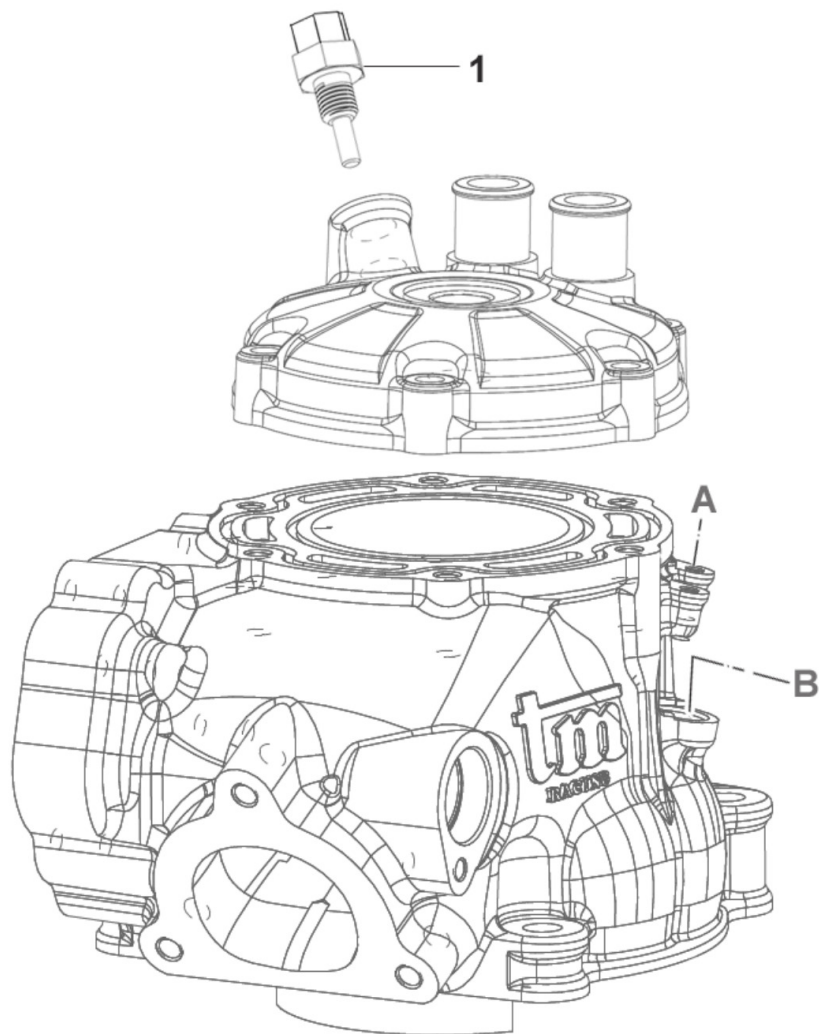



2T125FIEN21-M
MOTORE - ENGINE

SISTEMA INIEZIONE
INJECTION SYSTEM

2

1	08014	1	SENSORE TEMP. ACQUA TESTA 250/300 2T F.I. 19	SENSOR, WATER TEMPERATURE HEAD 250/300 2T Fi 19->
2	49557	4	VITE TBCE 4X16	BOLT TBCE 4x16
3	08006	1	Kit pre-assemblato Rail benz. CPL	RAIL FUEL PRE-ASSEMBLED ASSY
4	08027	1	CAPPUCCIO INIET. DX in plastica	
5	08028	1	CAPPUCCIO INIET. SX in plastica	
6	08033	2	INIETTORE KN7S 280cc/min.	
7	49600.2	4	RONDELLA NYLON M 4 4,3x9x0,8	
8	12269	1	SET OR + SEAL RING INIETTORE KEIHIN	SET OR + SEAL RING KEIHIN INJECTOR
9	26175	4	BOCCOLA SUPP. TUBI INIETTORE 2T MY20->	

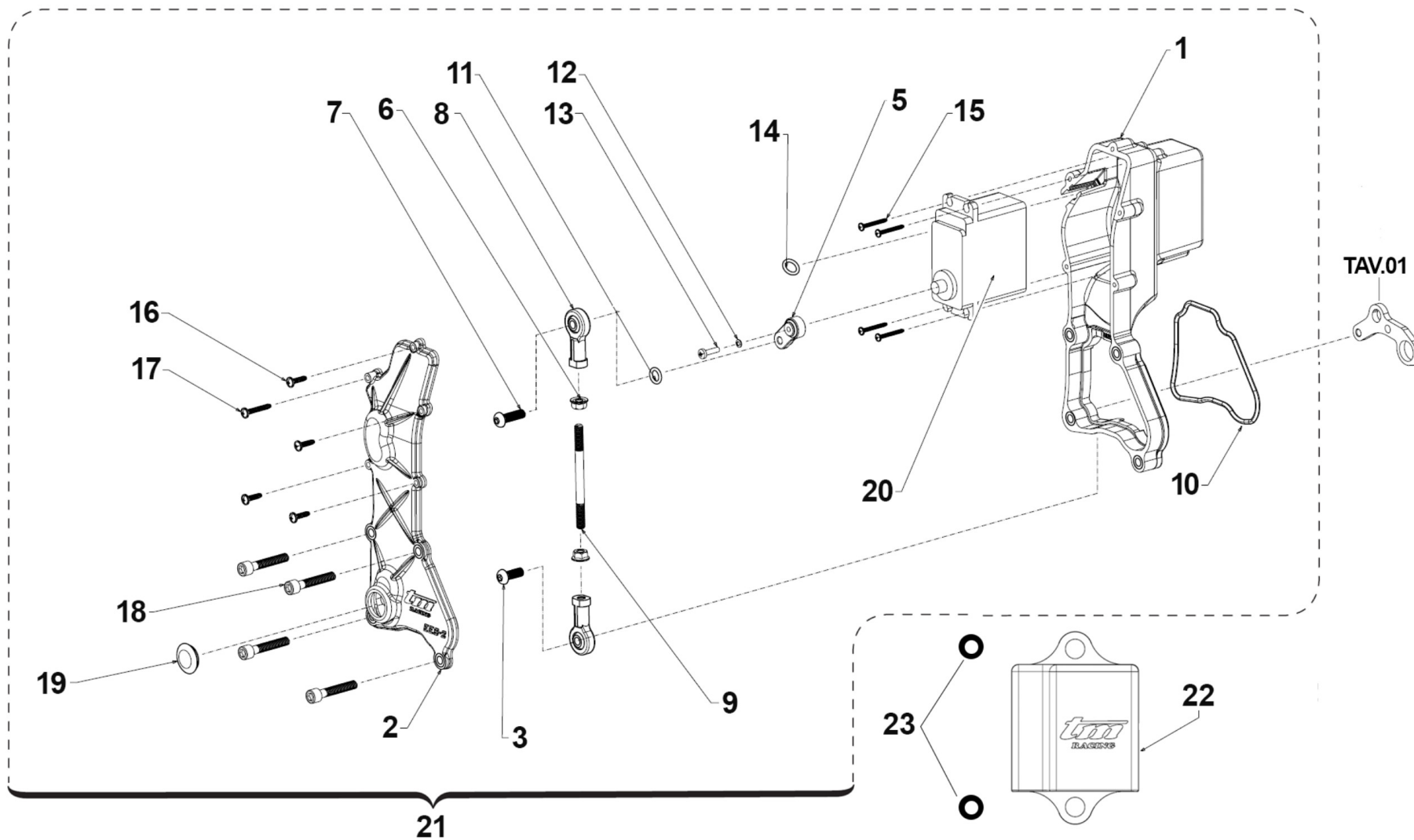



2T125FIEN21-M
MOTORE - ENGINE

MOTORINO VALVOLA
ELECTRIC VALVE SYSTEM

1	30291	1	MY20	CARTER EES-2 125/144 2T FI	CASE, PLASTIC, ENGINE VALVE
2	30392	1	MY20	COPERCHIO CARTER EES-2 125/144 2T FI	
3	49472	1	MY20	VITE TCEI 5X12 UNI 5931	BOLT TCEI 5X12
5	28266.0	1	MY20	LEVA SERVOMOTORE EES-2 DENTATURA 0	LEVER
5	28266.1	1	MY20	LEVA SERVOMOTORE EES-2 DENTATURA 1	LEVER
6	49632	2	MY20	DADO M 5 x 0,8 ZB	NUT 5mm
7	49929	1	MY20	VITE 10.9 TBCEI 5 x 18 UNI 7380	BOLT
8	72251	2	MY20	SNODO MECCANISCO VALVOLA EES-2 125/250/300	JOINT EXHAUST VALVE EES-2 250/300
9	28109	1	MY20	ASTINA COLLEGAMENTO UNIBALL EES-2 125/144 2020	ROD, UNIBALL 125/144 MY20
10	12042	1	MY20	O RING COP. VALVOLA EES-2	O-RING
11	F12301	1	MY20	O RING 106 4T PIOGGIA CAMBIO	O-RING, 106 GEAR F.S.
12	49124	1	MY20	RONDELLA SCHNORR ZIG. 2.5	
13	49881	1	MY20	VITE T.C. 2,5X12	
14	F12321	1	MY20	O RING BOCCOLA CENTR. CILINDRO	O-RING
15	49973	4	MY20	VITE STS-Plus KN6031 2.2X20 PLASTICA	BOLT
16	49984	4		VITE TCBL 3.0 X 12 FL. PLASTICA	BOLT
17	49919	5	MY20	VITE TCBL 3.0X 20 FL. X PLAST.	BOLT
18	49478	4	MY20	VITE TCEI 5X30 UNI 5931	BOLT TCEI 5X30
19	21009	1	MY20	TAPPO GOMMA COPERCHIO VALV.SC.	RUBBER, COVER
20	22500	1	MY20	SERVOMOTORE VALV.SCARICO HITEC	EL. ENGINE EXHAUST VALVE HITEC
21	22502.20	1		SERVOMOTORE V/SC. CPL 125/144 MY20	EL. ENGINE EXHAUST, 125/144 MY20 ASSY
22	08023	1		CENTRALINA COMANDO VALV.SC. 250/300 EES-2 125 Fi	ECU EXHAUST VALVE CONTROL 250/300 2S EES-2
23	F21444	2		GOMMINO CENTRALINA COMANDO VALV. MY 2019	RUBBER ECU HOLDER EXHAUST VALVE M.19->

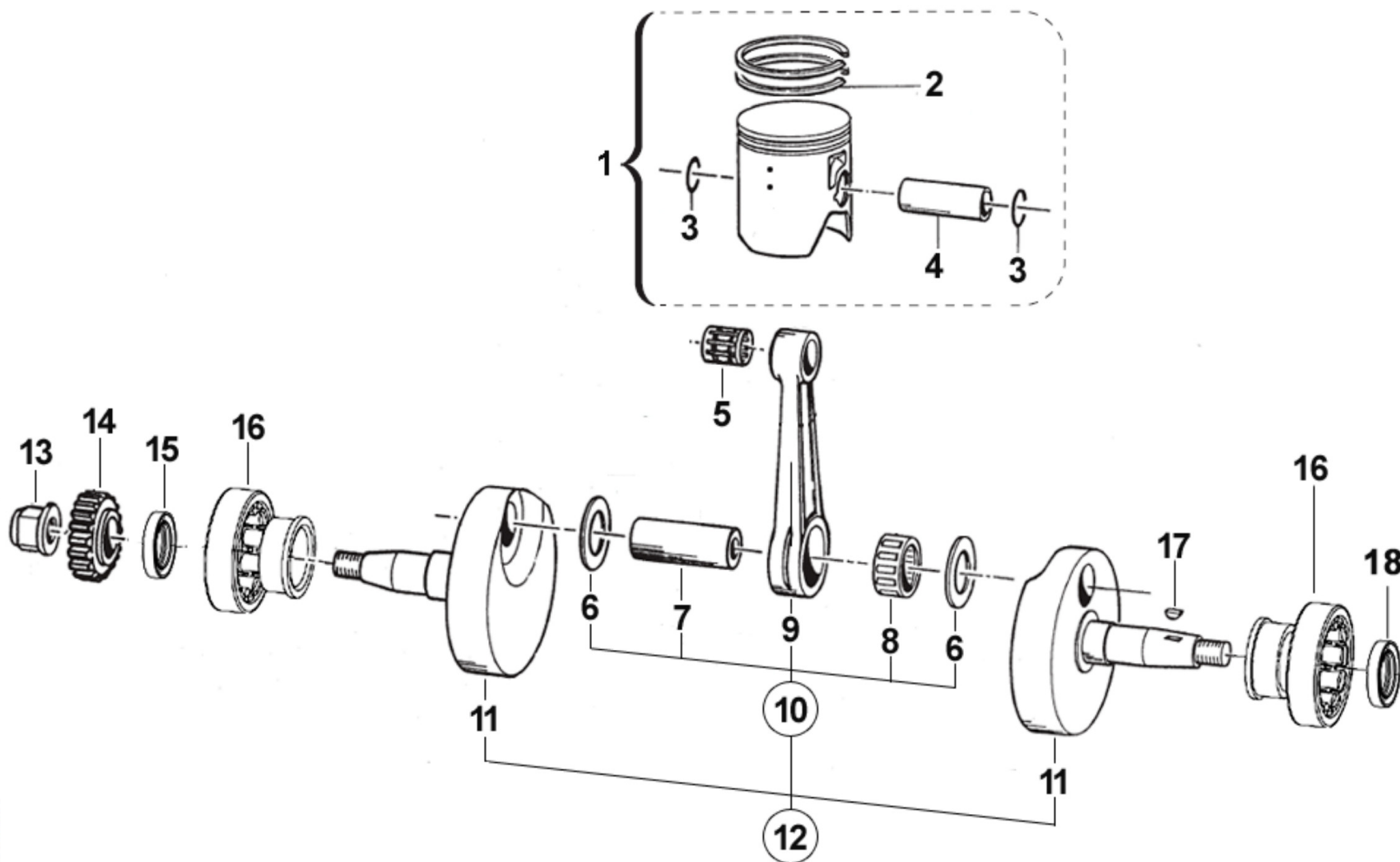

TM125FI20-004



2T125FIEN21-M
MOTORE - ENGINE

ALBERO MOTORE E PISTONE
CRANKSHAFT AND PISTON

4

1	10022.94	1	PISTONE 53.94 125 2014 2F(0,8)	PISTON 53.94 125CC M14 2 R.0,8
1	10022.95	1	PISTONE 53.95 125 2014 2F(0,8)	PISTON 53.95 125CC M14 2 R.0,8
1	10022.96	1	PISTONE 53.96 125 2014 2F(0,8)	PISTON 53.96 125 M.14-> 2R.0,8
1	10022.97	1	PISTONE 53.97 125 2014 2F(0,8)	PISTON 53.97 125 M.14-> 2R 0,8
1	10022.98	1	PISTONE 53.98 125 2014 2F(0,8)	PISTON 53.98 125 M.14-> 2R 0,8
2	11069	2	SEGMENTO 54,00 X 0,80 TPR	PISTON RING 54,00 X 0,80 TPR
3	09004.1	2	ANELLINO SPINOTTO PIST.125/144	CLIP, PISTON PIN 125 / 144
4	09008	1	SPINOTTO PISTONE 125 15X41F10	PIN, PISTON 125, 15x41 F10
5	19034	1	GABBIA SPINOTTO 15X19X17,3	TOP END B. 15X19X17,3
6	18239	2	RONDELLA ARGENTATA D.22 X 1 v2	WASHER, SILVER ID 22 X 1
7	18025	1	ASSE ACCOP. 22 X 50.4 F5 125K	CRANKPIN 22X50,4 H.5mm 125K
8	17015	1	GABBIA ARGENTATA 222815	SILVER CAGE 22X28X15
9	18053.2	1	BIELLA ASSE 22 FORG. NUDA 109,8	CONROD D.22mm FORGED 109,8
10	18125.2	1	BIELLA KZ10-B 22 CPL ASSE F.5	CONROD ASSY KZ10-B 22 PIN H.5
11	18275	1	COPPIA SEMIALBERI 125 Fi MY20	
12	18280	1	ALBERO MOTORE CPL 125 Fi MY20	
13	49094	1	DADO TRASMISS.125 06 M 14 X 1.25	NUT,CLUTCH CENT.14X1.25 125 06
14	40303	1	PIGNONE COPPIA PRIMARIA Z19 CR	PRIMARY DRIVE GEAR 19T MX
14	50030	1	ESTRATTORE PIGNONE COPPIA	PRIMARY GEAR PULLEY
15	04035	1	PARAOLIO 20x30x7 PTFE	OIL SEAL 20 x 30 x 7 PTFE
16	03029	2	CUSCINETTO BC1-1442 B	BUSH, BC1-1442 B KZ10
17	49012	1	CHIAVETTA PIGNONE COPPIA 250	WOODRUFF KEY, 250/300 19x7,5x5
18	04039	1	PARAOLIO 22x33x7 PTFE	

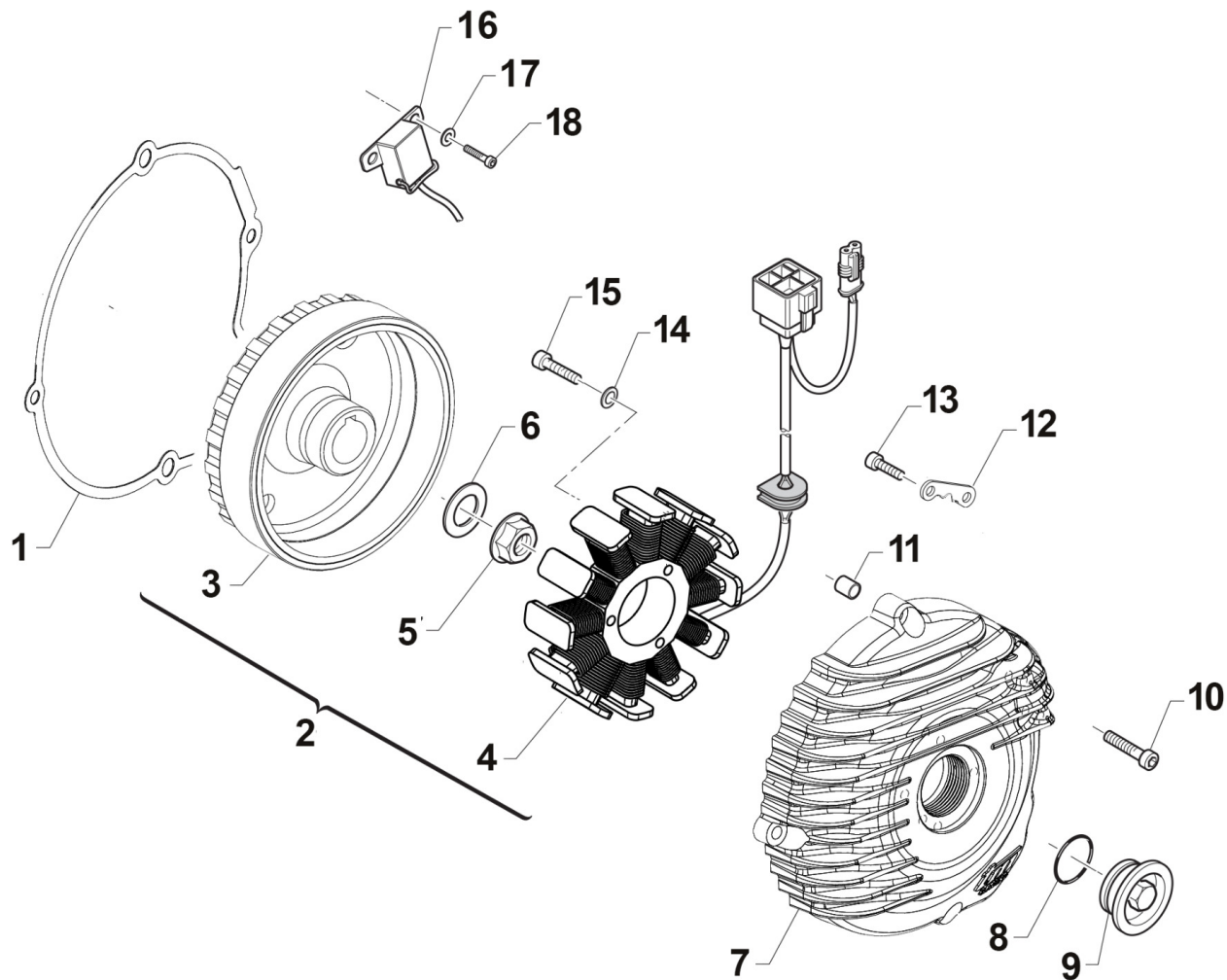

TM125FI20-005



2T125FIEN21-M
MOTORE - ENGINE

ACCENSIONE
IGNITION

5

1	05536	1	GUARN. COP.ACC. 125/144 Fi 2020	
2	15256	1	ACCENSIONE CPL 125 Fi MY2015251 + F15551	
3	15251	1	ROTORE X GEN. KS 125/144 2T IE CPL M.2020	
4	F15551	1	STATORE KOKUSAN YS 9022	STATOR KOKUSAN YS 9022
5	49056	1	DADO ACCENS 100/TAG/KZ 125MX/E	NUT, IGNITION 100cc
6	49613	1	RONDELLA ACCIAIO 12	STEEL WASHER 12
7	30279	1	COPERCHIO ACCENSIONE 125/144Fi 2T 20->	
8	F12322	1	O RING 2106	O-RING
9	49290	1	TAPPO COPERCHIO ACC. 250/300 2T MY 2019(PUO' SOSTITUIRE F49833)	CAP IGNITION COVER 250/300 2S MY19
10	49477	4	VITE TCEI 5X25 UNI 5931	BOLT TCEI 5X25
11	26041	2	GRANO CENTRAGGIO D.7X8 F.5,2	DOWEL PIN 7 x 8 Hole 5,2
12	69213	1	PIASTRINO ACC. 125Fi E FISS.FLANGIA DISC.SM	
13	49556	2	VITE TBCE 4X10	BOLT TBCE 4x10
14	49615	4	RONDELLA ACCIAIO 5x11x0,5	WASHER STEEL 5 mm
15	49477	4	VITE TCEI 5X25 UNI 5931	BOLT TCEI 5X25
16	F15478	1	PICK-UP KOKUSAN	PICK-UP KOK PU5157
17	49601	2	RONDELLA 5X11	WASHER 5x11
18	49472	2	VITE TCEI 5X12 UNI 5931	BOLT TCEI 5X12

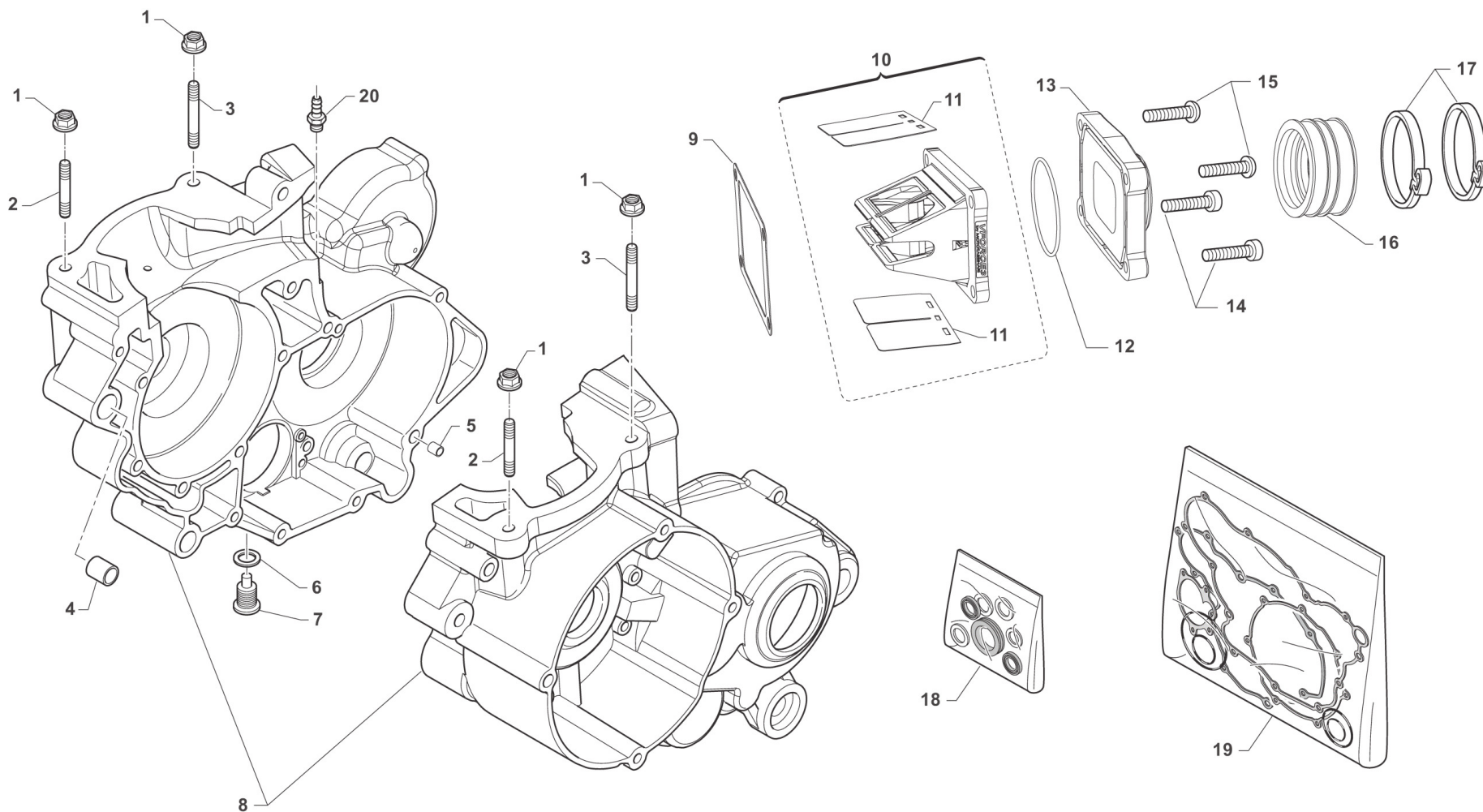

TM125FI20-M-06



2T125FIEN21-M
MOTORE - ENGINE

BASAMENTO E PACCO

1	49640	4	DADO M 8 FLANGIATO CHIAVE 12	NUT 8mm, FLANGE
2	49020	2	PRIGIONIERO CIL.48 mm 80/125	STUD CYL.48mm 80/125cc
3	49027	2	PRIGIONIERO CIL.58 KV-K7-K8-K9	STUD 8 X 58 mm
4	26043	1	GRANO CARTER ANT. 14 X 14	GRUB SCREW 14X14
5	26044	1	GRANO CENTRAGGIO MOTOR.10X13,6	GRUB SCREW 10X13,6
6	49103	1	RONDELLA 14X20X1,5 ALLUMINIO	WASHER, 14 X 20 X 1.5 ALUMINUM
7	49301	1	TAPPO OLIO C/CALAM. 2T	OIL PLUG WITH MAGNET
8	30298	1	BASAMENTO MOTORE 125 Fi MY 2020	
9	05277	1	GUARN. PACCO LAMELLE VFORCE 3	GASKET, REED BLOCK VFORCE 3
10	20061	1	PACCO LAM 125/144 VF3 M. 08/->	REEDS BOX VF3 125/144 M. 08/->
11	20074	1	LAMELLE V-FORCE3 125/144 07/->	REEDS, V-FORCE3 125/144 07/->
12	12026	1	O RING CONVOGLIATORE 125 13086	O-RING INLET MANIFOLD 125 13086
13	13086	1	COLLETTORE AI ASP. 125cc 2013	ALL. INTAKE MANIFOLD 125 cc M.13->
14	49485	2	VITE TCEI 6X25 UNI 5931	BOLT TCEI 6x25
15	49173	2	VITE DI SICUREZZA FL. M6X25	
16	13009	1	MANICOTTO COLLETTORE ASP.97/14	MANIFOLD RUBBER,INTAKE M.97/14
17	51054	1	FASCETTA SM9 D.52	CLAMP SM9 D.52mm
18	04041	1	KIT PARAOLI 125/144 Fi MY20	
19	05626	1	KIT GUARN. + OR 125/144 Fi MY2020	
20	49009	1	RACCORDO SFIATO OLIO MX/E F.4	JOINT, OIL BREATHER

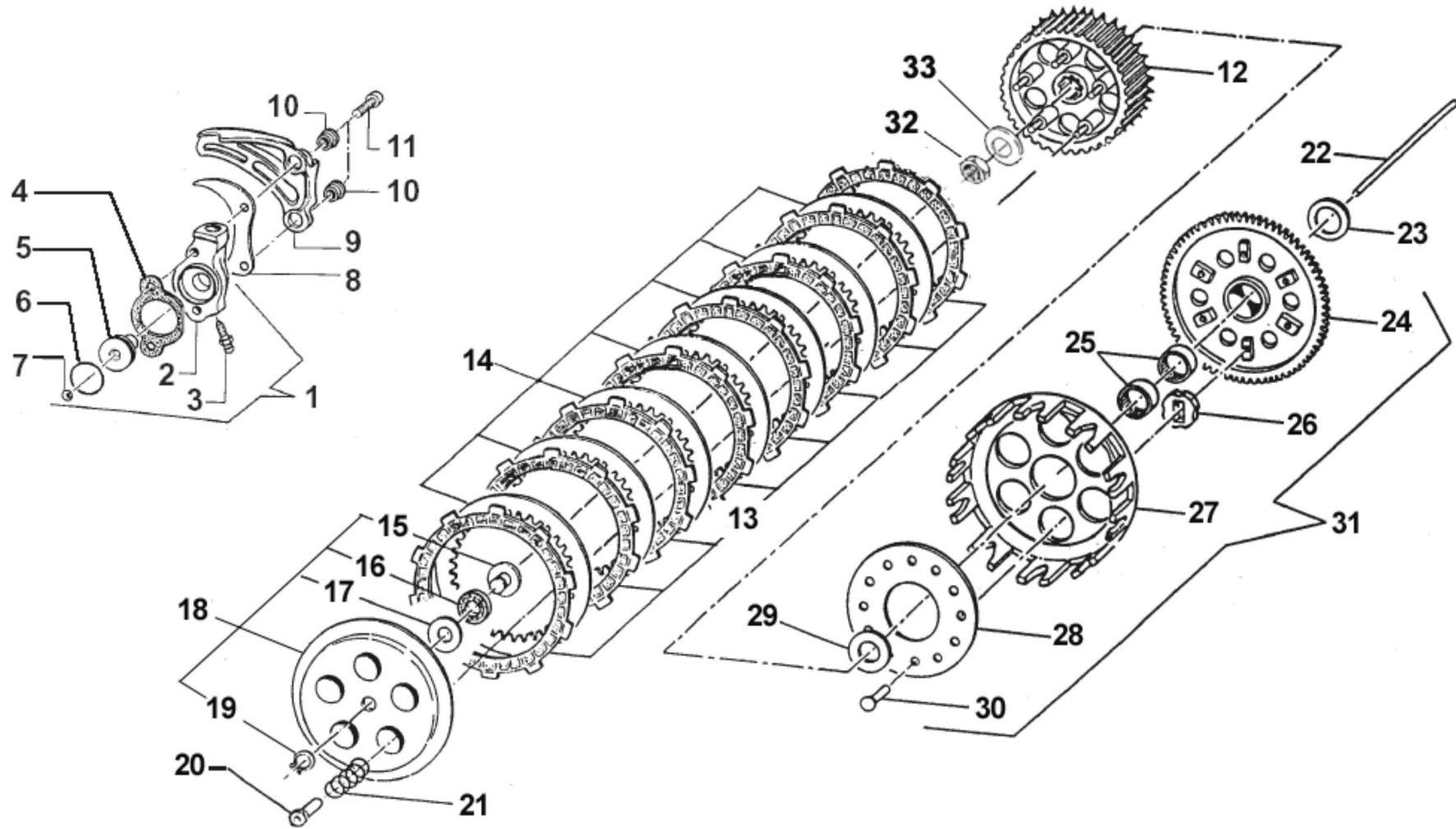



2T125FIEN21-M
MOTORE - ENGINE

FRIZIONE
CLUTCH

1	30206	1	COP. FRIZ/IDR 85/125 95/-> CPL	OUTPUT H.CLUTCH CYLINDER CPL.
2	30205	1	COP. FRIZ/IDR 80/125 95/11 NUD	OUTPUT H.CLUTCH CYLINDER
3	35264	1	VITE SPURGO OLIO FRIZ.IDR.6X1	SCREW AIR BLED HYDRAUL.CLUTCH
4	05509	1	GUARN. POMPA FRIZ.IDR. 80/125	GASKET, HYDRAULIC CLUTCH80/125
5	35125	1	PISTONE POMPA FRIZ. 125 95/->	PISTON, CLUTCH PUMP 125 95/04
6	12259	1	O RING PISTONE FR.125/250VERDE	O-RING, CLUTCH PISTON 125/250
7	19052	1	SFERA 8 X FRIZIONE 250 5/16"	BALL, IDR. CLUTCH PUMP
8	40022	1	PROTEZIONE ERGAL PIGNONE CAT.	PROTECTION, GEAR CHAIN ERGAL
9	40029	1	PROTEZIONE PIGNONE 09/-> PLAST	PROTECTION FRONT SPROCKET09/13
10	26212	2	BOCCOLA PROT. PIGNONE 125 F.6	COLLAR, SPROCKET 125cc H.6
11	49486	2	VITE TCEI 6X30 UNI 5931	BOLT TCEI 6X30
12	25099.14	1	TAMBURELLO FRIZIONE 125 2014	CLUTCH CENTRE 125cc M.14->
12	50124	1	CHIAVE FRIZ. 85/125 + KART CPL	CLUTCH TOOL 85/125cc + KART
13	35012	8	DISCO FRIZ. GUARN.CR/E M.93->	CLUTCH PLATE, FIBER MX/E 93/->
14	35019	7	DISCO FRIZ. ACC. 1mm 99/05	CLUTCH PLATE, STEEL 1mm 99/05
15	26001	1	REGGISPINTA FRIZIONE	CLUTCH THRUST
16	19020	1	GABBIA A RULLI RAD. AXK 1024	NEEDLE CAGE AXK 1024, RADIAL
17	19021	1	RONDELLA X GABBIA RULLI AS1024	WASHER, NEEDLE CAGE AS 1024
18	35025	1	PIATTO SPING.FRIZ 125/KART CPL	PLATE, CLUTCH PRESSURE ASSY
19	49211	1	SEEGER E10x1 ANELLO PIATT.REG.	CIRCLIP D.8,4 - EXTERNAL
20	49057	5	DADO FRIZIONE ERGAL KZ10	NUT, CLUTCH KZ10 ERGAL
21	16020	5	MOLLA FRIZIONE 125 C/E 03/08BA	SPRING, CLUTCH 125 MX/E 03/->
22	35043	1	ASTINA FRIZ. IDR. 125 M.99/10	ROD, HYDR.CLUTCH 125 M. 99/04
23	48003	1	SPESSORE COP.PRIM.30X20X2	SPACER 30X20X2 PRIMARY GEAR
24	40402	1	COPPIA PRIM. 125 Z63	PRIMARY GEAR 63T, 125cc
25	19013	2	GABBIA A RULLI K 20X24X12	NEEDLE CAGE 20 X 24 X 12
26	21005	6	GOMMINO PARASTRAPPI FRIZIONE	RUBBER, CLUTCH BASKET
27	25000	1	CAMPANA FRIZ.125 M.91/96 99/13	CLUTCH BASKET 125 91/96 99/05



2T125FIEN21-M
MOTORE - ENGINE

FRIZIONE
CLUTCH

28	35026	1	DISCO BATTUTA GOMM. FRIZ.KZ10B	DISC STOP RUBBERS CLUTCH KZ10B
29	48002	1	SPESSORE COP.PRIM.30X18X3	SPACER 30x18x3
30	49727	6	VITE PARASTRAPPI K9 M7X1X12.5	SCREW, M7X1X12,5 K9 ENGINE
31	40409	1	COPPIA PRIM. 125 Z63 CPL 99/-> 93/96	PRIM.GEAR 63T,125 Comp. 99/04
32	49052	1	DADO TAMBURELLO FRIZIONE	NUT, CLUTCH CENTER
33	49127	1	MOLLA A TAZZA DIN 2093 28X14,2X1,25	DISC SPRING DIN 2093 28x14,2x1,25

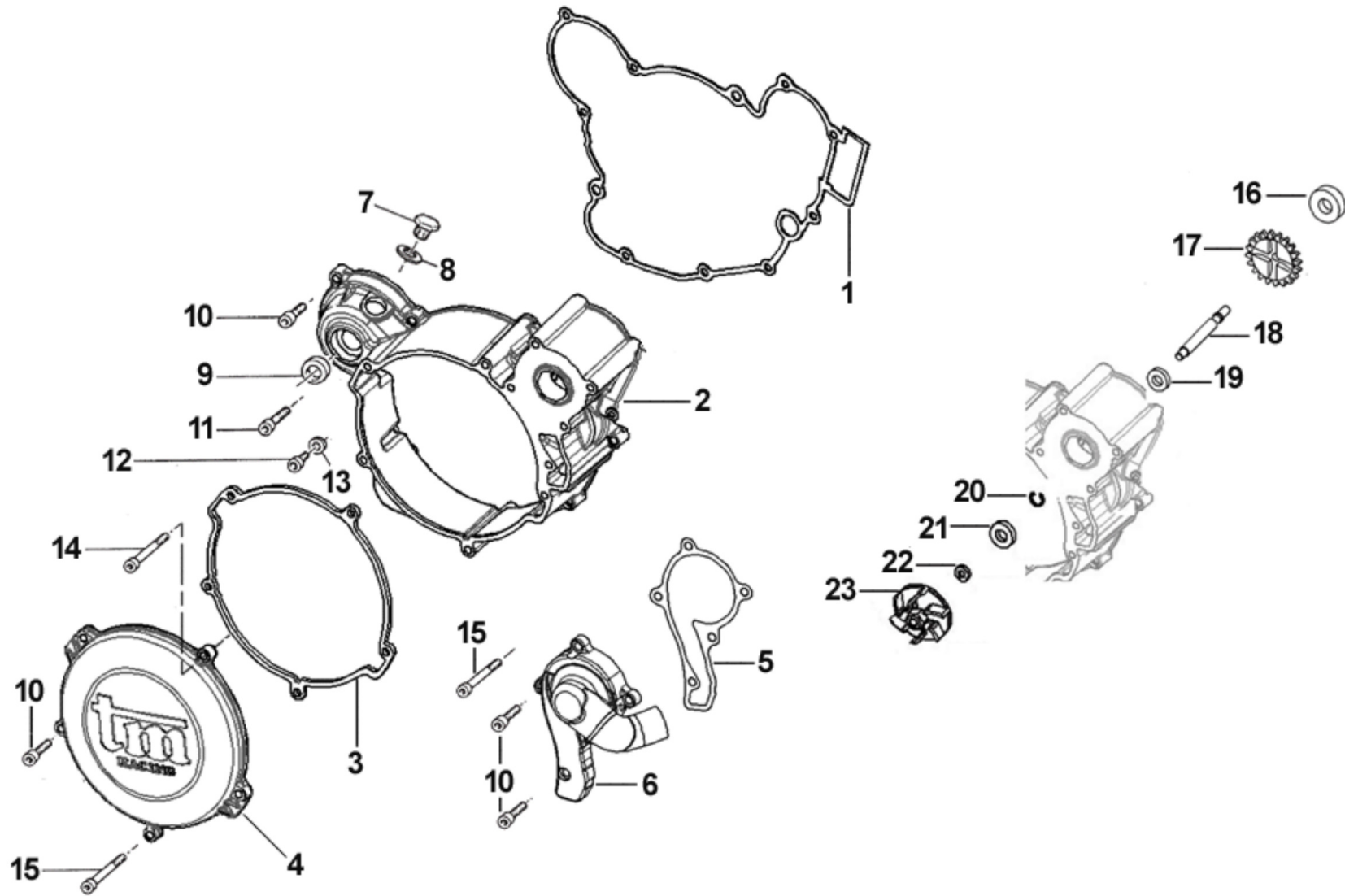



2T125FIEN21-M
MOTORE - ENGINE

COPERCHI FRIZIONE
CLUTCH CASE

1	05527	1	GUARN. COP.FRIZ. INT.125 06/->	GASKET, CLUTCH CASE 125 06/->
2	30174	1	CARTER FRIZIONE 125 M.12/->	CLUTCH COVER 125 M.12->
3	05526	1	GUARN. COP.FRIZ. EST.125 06/->	GASKET, EXT.CLUTCH COVER 125/6
4	30187	1	COPERCHIETTO FRIZ. 125 M.2006	COVER, CLUTCH, EXT. 125 06/->
5	05528	1	GUARN. POMPA ACQUA 125 2006	GASKET WATER PUMP 125cc 2006
6	30194.06	1	COPERCHIO POMPA H2O CR/E 06/->	WATER PUMP COVER MX/E M.2006
7	49300	1	TAPPO CARICO OLIO	OIL PLUG, FILL
8	49103	1	RONDELLA 14X20X1,5 ALLUMINIO	WASHER, 14 X 20 X 1.5 ALUMINUM
9	04005	1	PARAOLIO ALBERINO M/M 15x24x7	OIL SEAL 15 x 24 x 7
10	49476	12	VITE TCEI 5X20 UNI 5931	BOLT TCEI 5X20
11	49477	1	VITE TCEI 5X25 UNI 5931	BOLT TCEI 5X25
12	49480	1	VITE TCEI 6X10 UNI 5931	BOLT TCEI 6X10
13	49104	1	RONDELLA 6 x 10 x 1,5 ALLUMINIO	WASHER 6 x 10 x 1.5 ALUMINUM
14	49594	1	VITE TCEI 5X85 UNI 5931	SCREW TCEI 5X85
15	49595	3	VITE TCEI 5X80	BOLT TCEI 5X80
16	03025	1	CUSCINETTO 626 C3 POMPA H2O 06	BUSH, WATER PUMP 626 C3
17	40071	1	INGR COMANDO POMPA H2O 125 '12	GEAR, WATERPUMP 125 M.12/->
18	28062	1	ALBERINO POMPA ACQUA 125 2012	SHAFT, WATERPUMP 125 M.12/->
19	03014	1	CUSCINETTO 608 ZC3 POMPA SCHER	BUSH, WATER PUMP 608 Z C3
20	49215	1	SEEGER I22 POMPA ACQUA	CIRCLIP D.22 WATER PUMP
21	04017	1	PARAOLIO CENTRIFUGA 06 +MF1TAG	OIL SEAL 8 X 22 X 7 TC
22	49689	1	RONDELLA 6 X 12 SP. 1.2	WASHER 6x12 sp. 1,2
23	28009	1	GIRANTE POMPA ACQUA 2006/08	IMPELLER, WATER PUMP M.06/->

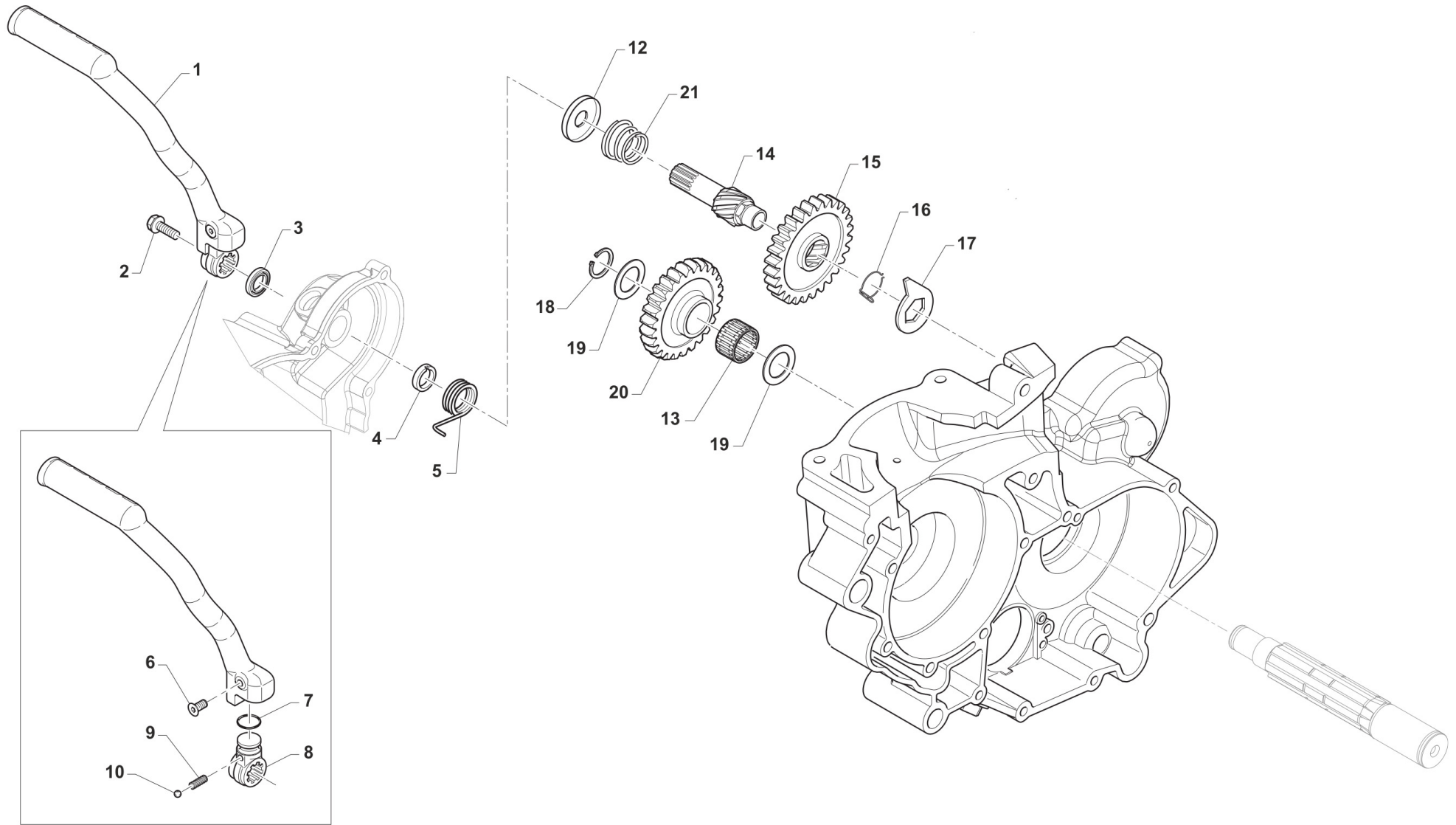

TM12521-M-009



2T125FIEN21-M
MOTORE - ENGINE

MESSA IN MOTO
KICK STARTER

1	43038	1	LEVA M/M 80/125 M. 99/->	LEVER, KICK STARTER 125 99/->
2	49368	1	VITE TE F/R 6X10 LEVA M/M	BOLT 6X10 (Kich Starter)
3	04005	1	PARAOLIO ALBERINO M/M 15x24x7	OIL SEAL 15 x 24 x 7
4	26005	1	DISTANZIALE MOLLA M/M	SPACER, KICK STARTER SPRING
5	16008	1	MOLLA M/M 80 / 125 / 144 cc	SPRING, KICK STARTER
6	49406	1	VITE TSEI 6X20	BOLT TSEI 6x20
7	12260	1	O RING INTERNO LEVA M/M 250	O-RING INT.LEVER KICK START250
8	43039.01	1	MOZZETTO KICK START 125 M. 96 ->	
9	16039	1	MOLLA X SFERA LEVA M/M 250 CC	SPRING, BALL KICK-START. 250cc
10	43250.03	1	SFERA 1/4C X LEVA M/M 250 CC	BALL, KICK STARTER LEVER 250cc
12	26188	1	PIATTELLO MOLLA CONTRASTO M/M 125	
13	19010	1	GABBIA A RULLI K 15X19X10	BUSH NEEDLE CAGE 15 X 19 X 10
14	28051	1	ALBERO MESSA IN MOTO 125/144 96/18	SHAFT, KICK STARTER 125 96/05
15	40350	1	INGRANAGGIO SCORREVOLE M/M 125 / 144	SLIDING GEAR, KICK STARTER 125
16	16006	1	MOLLA X INGRANAGGIO M/M	SPRING, KICKSTART SLIDING GEAR
17	26254	1	LEVA BATTUTA M/M 125/250 96/->	STOPPER, KICK STARTER
18	49214	1	SEEGER E15 INGRANAGGIO M/M	CIRCLIP GEAR K.S. 15mm
19	48004	2	SPESSORE INGRANAGGIO M/M	SPACER, K.STARTER GEAR
20	40351	1	INGRANAGGIO LIBERO M/M 125 / 144	GEAR, KICK STARTER 125
21	F16416	1	MOLLA DI CONTRASTO M/M 4T	SPRING K.STARTER 4S

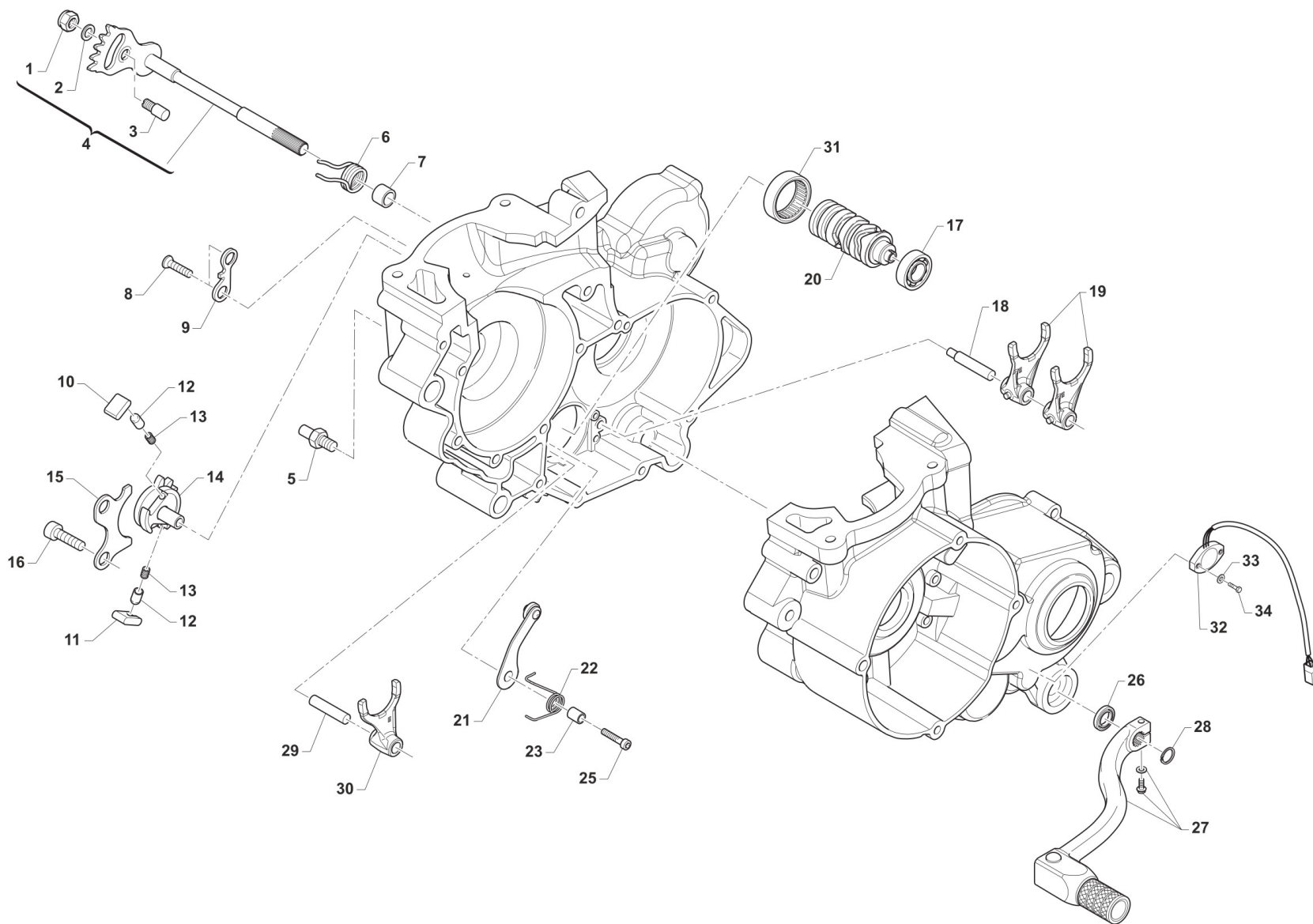

TM125FI20-M-010



2T125FIEN21-M
MOTORE - ENGINE

COMANDO CAMBIO
GEARSHIFT MECHANISM

1	49638	1	DADO M 6 ALTO AUTOBLOCCANTE	NUT 6mm, HIGHT SELF-LOCKING
2	49603	1	RONDELLA M 6,4 X 12 X 1,6	WASHER 6x12
3	26050	1	BATTUTA ECCENTRICA	ADJUSTER SELECTOR SHAFT
4	28100	1	ALBERO COMANDO ING. P.TACRIC.	SHAFT, GEARSHIFT
5	26051	1	BATTUTA FISSA LEVA CAMBIO INT.	PLATE INT. END STROKE GEAR LEVER
6	16009	1	MOLLA RITORNO LEVA CAMBIO 32CR	SPRING, RETURN GEAR LEVER 3,2
7	26006	1	DISTANZIALE MOLLA LEVA CAMBIO	SPACER, GEAR LEVER SPRING
8	49405	2	VITE TSEI 6X20 UMB.5933 10.9	BOLT TSEI 6x20 U.5933 10.9
9	26022	1	PIASTRINO FINE CORSA	PLATE END STROKE GEAR LEVER
10	26060	1	CRICCHETTO CAMBIO SUPERIORE	RATCHET UP, GEAR
11	26061	1	CRICCHETTO CAMBIO INFERIORE	RATCHET DOWN, GEAR
12	26062	2	PUNTALE PER CRICCHETTO CAMBIO	PIN, RATCHET GEAR
13	16012	2	MOLLA PER PUNTALE	SPRING, GEARBOX PIN
14	40310	1	INGRANAGGIO PORTACRICCHETTI	DRUM SHIFTER GEAR
15	26021	1	PIASTRINO RIENTRO CRICCHETTI	PLATE, RATCHET
16	49483	2	VITE TCEI 6X16 UNI 5931	BOLT TCEI 6X16
17	03012	1	CUSCINETTO DESMODROMICO 6001 2RS	BUSH, 6001 2RS GEAR DRUM
18	33256	1	PERNO FORCH.ALB.SEC. 250 / 125.99	AXEL, COUNTERSHAFT FORK 250cc
19	F33314	2	FORCHETTA A/S 125/250/300 CROM	SHIFT FORK SECONDARY 125/250CR
20	33008	1	ALBERO DESM.125 Fi INTEGR. 6M CPL	
21	26063.12	1	PIASTRINO BLOCCAMARCE 2012 CPL	PLATE STOP GEAR ASSY M.12->
22	16252	1	MOLLA BLOCCAMARCE 125 / 250 2T	
23	26007	1	DISTANZIALE MOLLA BLOCCAMARCE	SPACER, STOP GEAR SPRING
25	49485	1	VITE TCEI 6X25 UNI 5931	BOLT TCEI 6x25
26	04004	1	PARAOLIO POMPA H2O-LEVA CAMBIO	OIL SEAL 12 x 22 x 5
27	43049	1	LEVA CAMBIO 250 / 300 2T E.S. 19	GEAR LEVER 250 / 300 T.STR. EL.ST. M.19->
28	49212	1	SEEGER E12 LEVA CAMBIO	CIRCLIP D.12 - EXTERNAL
29	33255	1	PERNO FORCH.ALB. PRIM.250 / 125.99	AXEL, MAINSHAFT FORK 250cc



2T125FIEN21-M
MOTORE - ENGINE

COMANDO CAMBIO
GEARSHIFT MECHANISM

10

30	33016	1	FORCHETTA ALB.PRIM.125 PRT.CRM	SHIFT FORK MAINSHAFT 125 CROM.
31	19041	1	ASTUCCIO A RULLI DHK 35/12	BUSH NEEDLE CAGE DHK 35/12
32	F08236.1	1	SENSORE POSIZ.CAMBIO RFD-4021 CABLATO	SENSOR GEAR POSITION RFD-4021 W/WIRE
33	49926	2	RONDELLA 3X9X1	WASHER 3 X 9 X 1
34	49922	2	VITE TE 3X14	

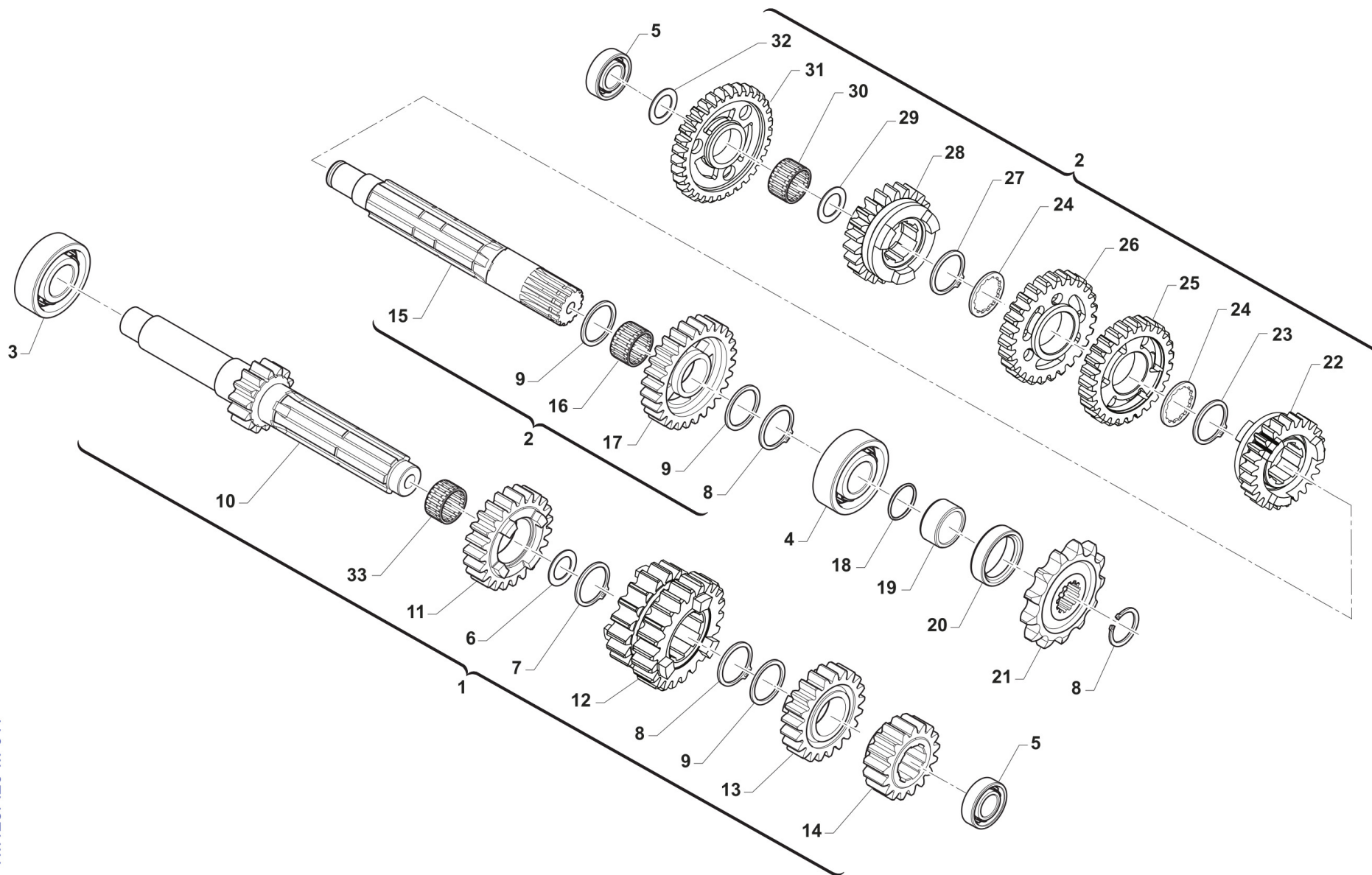

TM125FI20-M-011



2T125FIEN21-M
MOTORE - ENGINE

CAMBIO
GEAR BOX

1	40001.01	1	ALBERO PRIM. CPL 125 END/SMR	MAINSHAFT ASSY 125cc END/SMR
2	40002.01	1	ALBERO SECON. CPL 125 END/SMR	COUNTERSHAFT ASSY 125cc E/SMR
3	03011	1	CUSCINETTO ALBERO PRIM. 6204 Z C3	BUSH, GEAR MAINSHAFT
4	03010	1	CUSCINETTO 6204 C3 PIG.CATENA	BUSH, COUNTERSHAFT / SPROCKET
5	03080	2	CUSCINETTO 6202 Z C3 (CON RIVETTI) CAMBIO	BUSH, CRAKSHAFT CLUTCH SIDE
6	48041	1	RASAMENTO A/P 27.5X21X1 KZ10B	SPACER, MAINSHAFT 27,5X21X1 KZ
7	49222	1	SEEGER E 21 mm	CIRCLIP D.21 - EXTERNAL
8	49216	3	SEEGER E20 PIGN.-CAMBIO-COPPIA	CIRCLIP D.20 - EXTERNAL
9	48013	3	RASAMENTO A/S 27X20X0,7	SPACER, 27x20x0,7
10	40714	1	ALBERO PRIMARIO Z 13 END.RINF.	MAINSHAFT 13T END. REINFORCED
11	40440	1	INGR. A.P. 5a Z 22 K9B/C 10 CR/E90	GEAR, 5TH (22T) MAINSHAFT
12	40702	1	INGR A.P. 3/4a Z 18/20 CR/E 90	GEAR, 3/4TH(18/20T)MAINSH.MX/E
13	40452	1	INGR A.P. 6a Z 27 END	GEAR, 6TH (27T) MAINSHAFT END.
14	40701	1	INGR A.P. 2a Z 16 CR/E 90	GEAR, 2ND (16T) MAINSH.MX/E 90
15	40462	1	ALBERO SECONDARIO SCAN. 12	COUNTERSHAFT BR 12
16	19012	1	GABBIA A RULLI K 20X24X10	BUSH NEEDLE CAGE 20 X 24 X 10
17	40708	1	INGR A.S. 2a Z 29 CR/E 90	GEAR, 2TH (29T) COUNTERSH.CR/E
18	12019	1	O RING PIGNONE CATENA	O-RING, DRIVE GEAR 2075
19	26002.1	1	DISTANZIALE PIGNONE (MOTO)	SPACER, MOTORCYCLE GEAR
20	04003	1	PARAOLIO PIGN.CATENA (26x37x7)	OIL SEAL 26 x 37 x 7
21	40024	1	PIGNONE CAT. Z 11 BR12 M.00/->	SPROCKET 11T, DRIVE M.00/10
21	40025	1	PIGNONE CAT. Z 12 BR12 M.00/->	SPROCKET 12T, DRIVE 125 00/->
21	40026	1	PIGNONE CAT. Z 13 BR12 M.00/->	SPROCKET 13T, DRIVE 125 00/->
22	40522	1	INGR A.S. 6a Z 24 END	GEAR, 6TH (24T) COUNTERSH.END.
23	49217	1	SEEGER E22 ANELLO ALB/S	CIRCLIP D.22 - COUNTERSHAFT
24	48011	2	RASAMENTO DENT.A/S 27X22X0,75	SPACER, 27x22x0,75
25	40710	1	INGR A.S. 4a Z 25 CR/E 90	GEAR, 4TH(25T)COUNTERSH.MX/E90
26	40709	1	INGR A.S. 3a Z 27 CR/E 90	GEAR, 3RD(27T)COUNTERSH.MX/E90



2T125FIEN21-M
MOTORE - ENGINE

CAMBIO
GEAR BOX

27	49217.1	1	SEEGER RETTIFICATO PER 40510	SEEGER RING FOR CODE 40510
28	40510	1	INGR A.S. 5a Z 24 CR/E 90	GEAR, 5TH (24T) COUNTERSHAFT
29	48012	1	RASAMENTO A/S M/M SPESS.0,5	SPACER, 26x17x0,5
30	19011	1	GABBIA A RULLI K 17X21X10	BUSH CAGE 17 X 21 X 10
31	40706	1	INGR A.S. 1a Z 32 END/90	GEAR, 1ST(32T)COUNTERSH.END/90
32	48010	1	RASAMENTO ALB/S.28X15X0,5 INGI	SPACER, 28x15x0,5
33	19071	1	GABBIA A 20X24X10 IN DUE META'	NEEDLE CAGE 20X24X10 TWO PIEC.



2T125FIEN21-M
MOTORE - ENGINE

-

01127	2T125FIEN20-M-01	14	1
01135	2T125FIEN20-M-01	1	1
02028	2T125FIEN20-M-01	2	1
03010	2T125FI20-M-11	4	1
03011	2T125FI20-M-11	3	1
03012	2T125FI20-M-10	17	1
03014	2T125FI20-M-08	19	1
03025	2T125FI20-M-08	16	1
03029	2T125FI20-M-04	16	2
03080	2T125FI20-M-11	5	2
03156	2T125FIEN20-M-01	18	1
04003	2T125FI20-M-11	20	1
04004	2T125FI20-M-10	26	1
04005	2T12521-M-09	3	1
	2T125FI20-M-08	9	1
04017	2T125FI20-M-08	21	1
04035	2T125FI20-M-04	15	1
04039	2T125FI20-M-04	18	1
04041	2T125FI20-M-06	18	1
04115	2T125FIEN20-M-01	15	1
05277	2T125FI20-M-06	9	1
05509	2T125FI20-M-07	4	1
05526	2T125FI20-M-08	3	1
05527	2T125FI20-M-08	1	1
05528	2T125FI20-M-08	5	1
05530	2T125FIEN20-M-01	9	1
05531	2T125FIEN20-M-01	9	1
05532	2T125FIEN20-M-01	9	1

05533	2T125FIEN20-M-01	9	1
05534	2T125FIEN20-M-01	9	1
05535	2T125FIEN20-M-01	9	1
05536	2T125FI20-M-05	1	1
05626	2T125FI20-M-06	19	1
08006	2T125FI20-M-02	3	1
08014	2T125FI20-M-02	1	1
08023	2T125FI20-M-03	22	1
08027	2T125FI20-M-02	4	1
08028	2T125FI20-M-02	5	1
08033	2T125FI20-M-02	6	2
09004.1	2T125FI20-M-04	3	2
09008	2T125FI20-M-04	4	1
10022.94	2T125FI20-M-04	1	1
10022.95	2T125FI20-M-04	1	1
10022.96	2T125FI20-M-04	1	1
10022.97	2T125FI20-M-04	1	1
10022.98	2T125FI20-M-04	1	1
11069	2T125FI20-M-04	2	2
12003	2T125FIEN20-M-01	3	1
12019	2T125FI20-M-11	18	1
12021	2T125FIEN20-M-01	4	1
12026	2T125FI20-M-06	12	1
12042	2T125FI20-M-03	10	1
12259	2T125FI20-M-07	6	1
12260	2T12521-M-09	7	1
12269	2T125FI20-M-02	8	1
13009	2T125FI20-M-06	16	1

13081	2T125FIEN20-M-01	28	1
13086	2T125FI20-M-06	13	1
15251	2T125FI20-M-05	3	1
15256	2T125FI20-M-05	2	1
16006	2T12521-M-09	16	1
16008	2T12521-M-09	5	1
16009	2T125FI20-M-10	6	1
16012	2T125FI20-M-10	13	2
16020	2T125FI20-M-07	21	5
16039	2T12521-M-09	9	1
16066	2T125FIEN20-M-01	26	1
16252	2T125FI20-M-10	22	1
17015	2T125FI20-M-04	8	1
18025	2T125FI20-M-04	7	1
18053.2	2T125FI20-M-04	9	1
18125.2	2T125FI20-M-04	10	1
18239	2T125FI20-M-04	6	2
18275	2T125FI20-M-04	11	1
18280	2T125FI20-M-04	12	1
19010	2T12521-M-09	13	1
19011	2T125FI20-M-11	30	1
19012	2T125FI20-M-11	16	1
19013	2T125FI20-M-07	25	2
19020	2T125FI20-M-07	16	1
19021	2T125FI20-M-07	17	1
19034	2T125FI20-M-04	5	1
19041	2T125FI20-M-10	31	1
19052	2T125FI20-M-07	7	1



2T125FIEN21-M
MOTORE - ENGINE

-

19060	2T125FIEN20-M-01	13	1
19061	2T125FIEN20-M-01	33	1
19071	2T125FI20-M-11	33	1
20061	2T125FI20-M-06	10	1
20074	2T125FI20-M-06	11	1
21005	2T125FI20-M-07	26	6
21009	2T125FI20-M-03	19	1
22065.15	2T125FIEN20-M-01	31	1
22500	2T125FI20-M-03	20	1
22502.20	2T125FI20-M-03	21	1
25000	2T125FI20-M-07	27	1
25099.14	2T125FI20-M-07	12	1
26001	2T125FI20-M-07	15	1
26002.1	2T125FI20-M-11	19	1
26005	2T12521-M-09	4	1
26006	2T125FI20-M-10	7	1
26007	2T125FI20-M-10	23	1
26021	2T125FI20-M-10	15	1
26022	2T125FI20-M-10	9	1
26041	2T125FI20-M-05	11	2
26043	2T125FI20-M-06	4	1
26044	2T125FI20-M-06	5	1
26050	2T125FI20-M-10	3	1
26051	2T125FI20-M-10	5	1
26060	2T125FI20-M-10	10	1
26061	2T125FI20-M-10	11	1
26062	2T125FI20-M-10	12	2
26063.12	2T125FI20-M-10	21	1

26130.12	2T125FIEN20-M-01	29	1
26130.13	2T125FIEN20-M-01	29	1
26130.14	2T125FIEN20-M-01	29	1
26130.15	2T125FIEN20-M-01	29	1
26130.16	2T125FIEN20-M-01	29	1
26130.17	2T125FIEN20-M-01	29	1
26130.18	2T125FIEN20-M-01	29	1
26130.19	2T125FIEN20-M-01	29	1
26147	2T125FIEN20-M-01	30	1
26167	2T125FIEN20-M-01	34	1
26168	2T125FIEN20-M-01	24	1
26175	2T125FI20-M-02	9	4
26188	2T12521-M-09	12	1
26212	2T125FI20-M-07	10	2
26254	2T12521-M-09	17	1
26258	2T125FIEN20-M-01	16	1
28009	2T125FI20-M-08	23	1
28051	2T12521-M-09	14	1
28059	2T125FIEN20-M-01	32	1
28062	2T125FI20-M-08	18	1
28100	2T125FI20-M-10	4	1
28108	2T125FIEN20-M-01	21	1
28109	2T125FI20-M-03	9	1
28263	2T125FIEN20-M-01	23	1
28266.0	2T125FI20-M-03	5	1
28266.1	2T125FI20-M-03	5	1
30174	2T125FI20-M-08	2	1
30187	2T125FI20-M-08	4	1

30194.06	2T125FI20-M-08	6	1
30205	2T125FI20-M-07	2	1
30206	2T125FI20-M-07	1	1
30217	2T125FIEN20-M-01	11	1
30279	2T125FI20-M-05	7	1
30291	2T125FI20-M-03	1	1
30298	2T125FI20-M-06	8	1
30392	2T125FI20-M-03	2	1
33008	2T125FI20-M-10	20	1
33016	2T125FI20-M-10	30	1
33255	2T125FI20-M-10	29	1
33256	2T125FI20-M-10	18	1
35012	2T125FI20-M-07	13	8
35019	2T125FI20-M-07	14	7
35025	2T125FI20-M-07	18	1
35026	2T125FI20-M-07	28	1
35043	2T125FI20-M-07	22	1
35125	2T125FI20-M-07	5	1
35264	2T125FI20-M-07	3	1
40001.01	2T125FI20-M-11	1	1
40002.01	2T125FI20-M-11	2	1
40022	2T125FI20-M-07	8	1
40024	2T125FI20-M-11	21	1
40025	2T125FI20-M-11	21	1
40026	2T125FI20-M-11	21	1
40029	2T125FI20-M-07	9	1
40071	2T125FI20-M-08	17	1
40303	2T125FI20-M-04	14	1



2T125FIEN21-M
MOTORE - ENGINE

-

40310	2T125FI20-M-10	14	1
40350	2T12521-M-09	15	1
40351	2T12521-M-09	20	1
40402	2T125FI20-M-07	24	1
40409	2T125FI20-M-07	31	1
40440	2T125FI20-M-11	11	1
40452	2T125FI20-M-11	13	1
40462	2T125FI20-M-11	15	1
40510	2T125FI20-M-11	28	1
40522	2T125FI20-M-11	22	1
40701	2T125FI20-M-11	14	1
40702	2T125FI20-M-11	12	1
40706	2T125FI20-M-11	31	1
40708	2T125FI20-M-11	17	1
40709	2T125FI20-M-11	26	1
40710	2T125FI20-M-11	25	1
40714	2T125FI20-M-11	10	1
43038	2T12521-M-09	1	1
43039.01	2T12521-M-09	8	1
43049	2T125FI20-M-10	27	1
43250.03	2T12521-M-09	10	1
48002	2T125FI20-M-07	29	1
48003	2T125FI20-M-07	23	1
48004	2T12521-M-09	19	2
48010	2T125FI20-M-11	32	1
48011	2T125FI20-M-11	24	2
48012	2T125FI20-M-11	29	1
48013	2T125FI20-M-11	9	3

48041	2T125FI20-M-11	6	1
49009	2T125FI20-M-06	20	1
49012	2T125FI20-M-04	17	1
49020	2T125FI20-M-06	2	2
49027	2T125FI20-M-06	3	2
49052	2T125FI20-M-07	32	1
49056	2T125FI20-M-05	5	1
49057	2T125FI20-M-07	20	5
49094	2T125FI20-M-04	13	1
49103	2T125FI20-M-06	6	1
	2T125FI20-M-08	8	1
49104	2T125FI20-M-08	13	1
49124	2T125FI20-M-03	12	1
49127	2T125FI20-M-07	33	1
49173	2T125FI20-M-06	15	2
49211	2T125FI20-M-07	19	1
49212	2T125FI20-M-10	28	1
49214	2T12521-M-09	18	1
49215	2T125FI20-M-08	20	1
49216	2T125FI20-M-11	8	3
49217	2T125FI20-M-11	23	1
49217.1	2T125FI20-M-11	27	1
49220	2T125FIEN20-M-01	19	1
49222	2T125FI20-M-11	7	1
49290	2T125FI20-M-05	9	1
49300	2T125FI20-M-08	7	1
49301	2T125FI20-M-06	7	1
49355	2T125FIEN20-M-01	27	3

49358	2T125FIEN20-M-01	5	6
49368	2T12521-M-09	2	1
49399	2T125FIEN20-M-01	10	1
49405	2T125FI20-M-10	8	2
49406	2T12521-M-09	6	1
49472	2T125FI20-M-03	3	1
	2T125FI20-M-05	18	2
49476	2T125FI20-M-08	10	12
49477	2T125FI20-M-05	10	4
	2T125FI20-M-05	15	4
	2T125FI20-M-08	11	1
49478	2T125FI20-M-03	18	4
49480	2T125FI20-M-08	12	1
49483	2T125FI20-M-10	16	2
49485	2T125FI20-M-06	14	2
	2T125FI20-M-10	25	1
49486	2T125FI20-M-07	11	2
49556	2T125FI20-M-05	13	2
49557	2T125FI20-M-02	2	4
49594	2T125FI20-M-08	14	1
49595	2T125FI20-M-08	15	3
49600.2	2T125FI20-M-02	7	4
49601	2T125FI20-M-05	17	2
49603	2T125FI20-M-10	2	1
49613	2T125FI20-M-05	6	1
49615	2T125FI20-M-05	14	4
49630	2T125FIEN20-M-01	20	1
49632	2T125FI20-M-03	6	2



2T125FIEN21-M
MOTORE - ENGINE

-

49638	2T125FI20-M-10	1	1
49640	2T125FI20-M-06	1	4
	2T125FIEN20-M-01	8	4
49676	2T125FIEN20-M-01	35	1
49689	2T125FI20-M-08	22	1
49727	2T125FI20-M-07	30	6
49757	2T125FIEN20-M-01	17	1
49874	2T125FIEN20-M-01	22	1
49881	2T125FI20-M-03	13	1
49919	2T125FI20-M-03	17	5
49922	2T125FI20-M-10	34	2
49926	2T125FI20-M-10	33	2
49929	2T125FI20-M-03	7	1
49973	2T125FI20-M-03	15	4
49984	2T125FI20-M-03	16	4
50030	2T125FI20-M-04	14	1
50124	2T125FI20-M-07	12	1
51054	2T125FI20-M-06	17	1
69213	2T125FI20-M-05	12	1
72251	2T125FI20-M-03	8	2
F06105	2T125FIEN20-M-01	7	1
F08236.1	2T125FI20-M-10	32	1
F12301	2T125FI20-M-03	11	1
F12308	2T125FIEN20-M-01	12	1
F12321	2T125FI20-M-03	14	1
F12322	2T125FI20-M-05	8	1
F15478	2T125FI20-M-05	16	1
F15551	2T125FI20-M-05	4	1

F16416	2T12521-M-09	21	1
F19536	2T125FIEN20-M-01	25	1
F21418	2T125FIEN20-M-01	6	1
F21444	2T125FI20-M-03	23	2
F33314	2T125FI20-M-10	19	2