



---

USES AND  
RACOMMENDS



[www.tmracing.it](http://www.tmracing.it)

---

TM Racing SpA - Via Fano, 6  
61122 Pesaro - ITALY  
Phone: +39 0721 25113

## 4T250FIMX21-M

MOTORE  
ENGINE

27/02/2022



## INFORMAZIONI GENERALI

Il presente catalogo serve per richiedere con esattezza le parti di ricambio.

Nelle ordinazioni indicare:

**1) Il numero di matricola del Telaio** che è stampigliato sul lato destro del canotto di sterzo. Nei modelli EN, SMR, SMR il numero di matricola è riportato anche su una targhetta posta sul lato sinistro (Vedi foto).

**2) il numero di serie del Motore.** E' posto sulla sinistra del motore tra la leva cambio e i coperchio accensione (Vedi foto).

**3) Il codice dei particolari** seguito dalla descrizione.

**4) Il colore** per i pezzi verniciati o comunque colorati.

Le indicazioni destra e sinistra si riferiscono ai lati del veicolo rispetto al senso di marcia.

Foto e disegni sono solo a scopo informativo e potrebbero non corrispondere esattamente alle caratteristiche dei prodotti.

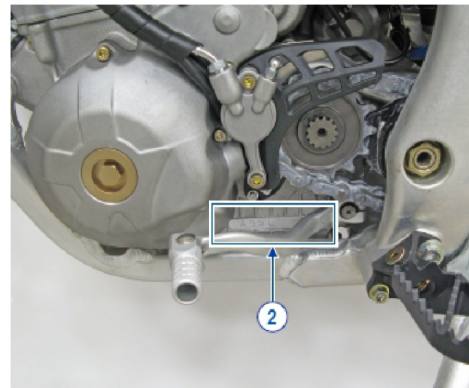
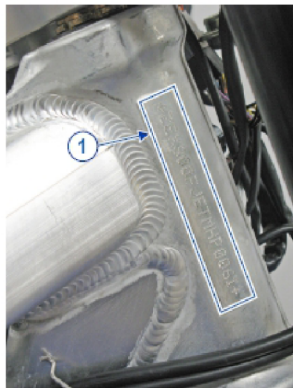

## GENERAL INFORMATION

The present spare parts catalogue enables one to order exactly the right spare part.

When ordering specify:

**1) The frame serial number.** It is embossed on the right side of the steering metal tube. In the EN, SMR and SMR models, the serial number is also stated on a plate positioned on the left hand side (See photo).

**2) The engine serial number.** It is located on the left side of the engine between the gear lever and the ignition cover (See photo).

**3) The part's code number** followed but its description.

**4) Indicate colour** for painted or colored parts.

References to right and left apply to the vehicle in terms of its direction of movement.

Photos and drawings are for informational purposes only and may not exactly match the characteristics of the products.

## NOTE – LEGENDA

**MY**

NOVITA' INTRODOTTA DIFFERENTE O NON PRESENTE NEL MODELLO DELL'ANNO PRECEDENTE

*PART DIFFERENT OR NOT PRESENT IN THE REVIOUS YEAR MODEL*

**5M**

MOTORE CON CAMBIO A 5 MARCE  
*ENGINE WITH 5 GEARS SPEED*

**6M**

MOTORE CON CAMBIO A 6 MARCE  
*ENGINE WITH 6 GEARS SPEED*

**KS**

MOTORE CON SOLO KICK STARTER  
*ENGINE WITH KICK STARTER ONLY*

**ES**

MOTORE CON AVVIAMENTO ELETTRICO  
*ENGINE WITH ELECTRIC STARTER*

**X**

RICAMBIO NON DISPONIBILE ALLA VENDITA  
*PART CAN NOT BE SOLD SEPARATELY*

Le illustrazioni riportate in questo manuale sono fornite solo come riferimento e possono variare dal prodotto effettivo,

Dati indicativi soggetti a modifiche senza impegno di preavviso.

The illustrations in this manual are for reference only and may vary from the actual product.

All data are subject to modification without prior notice.



**4T250FIMX21-M**  
**MOTORE - ENGINE**

CILINDRO - PISTONE - CYLINDER - PISTON.....	4
TESTA - HEAD.....	6
MANOVELLISMO - CRANKSHAFT.....	10
DISTRIBUZIONE - VALVES COVER.....	12
LUBRIFICAZIONE - LUBRIFICATION.....	15
CARTER MOTORE - CLUTCH CASE.....	18
FRIZIONE ADLER.....	20
FRIZIONE - CLUTCH.....	22
COMANDO CAMBIO - GEARSHIFT MECHANISM.....	25
CAMBIO 5 MARCE - 5 GEARS GEARBOX.....	28
CAMBIO 6 MARCE - 6 GEARS GEARBOX.....	31
AVVIAMENTO PEDALE - KICK STARTER.....	34
ACCENSIONE ES - IGNITION ES.....	36
ACCENSIONE KS - IGNITION KS.....	39
- .....	41



4T250FIMX21-M  
MOTORE - ENGINE

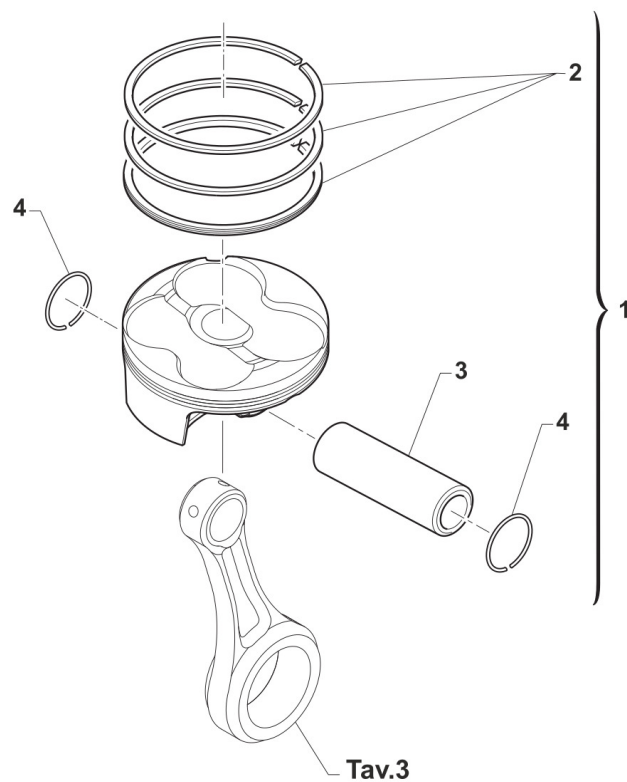

CILINDRO - PISTONE  
CYLINDER - PISTON

1

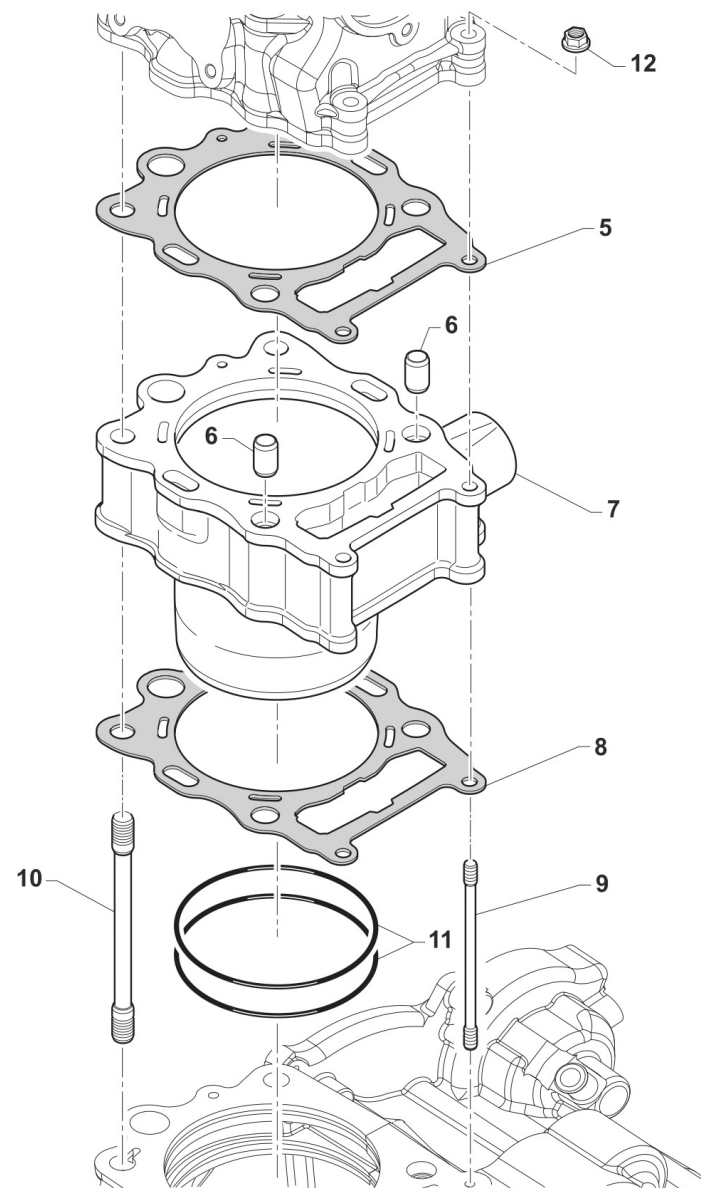

TM0001



**4T250FIMX21-M**  
**MOTORE - ENGINE**

**CILINDRO - PISTONE**  
**CYLINDER - PISTON**

**1**

1	F10863.95	1	PISTONE 250Fi MX 76.95 2018 CPL V	PISTON 250Fi MX 76.95 2018 ASSY V.
1	F10863.96	1	PISTONE 250Fi MX 76.96 2018 CPL V	
1	F10863.97	1	PISTONE 250Fi MX 76.97 2018 CPL V	PISTON 250Fi MX 76.97 M18 ASSY V
1	F10863.98	1	PISTONE 250Fi MX 76.98 2018 CPL V	PISTON 250Fi MX 76.98 M18 ASSY V
2	F11384	1	KIT SEGMENTI D.77 NPR	RINGS KIT D. 77mm NPR
3	F09396.2	1	SPINOTTO 16X10.5X36 BIC.DLC S2	PISTON PIN 16X10.5X36 DLC
4	F09385	2	ANELLINO D.16X1 VP	CIRCLIP D. 16X1 VP
5	F05862.1	1	GUARNIZIONE TESTA 250Fi TWIN D. 78	HEAD GASKET D. 77 3 LAYERS CH
6	F26428	2	GRANO RIFERIMENTO 12X13 F10.2	GRUB SCREW 12X13 H.10,2mm
7	F01727	1	CILINDRO 4T 250 TWIN Ø77 H=34,4 MMMX 18/21 EN 19/->	CYLINDER 250 N FS D. 77mm R.
8	F05856.1	1	GUARNIZ.CIL/BAS SP.0,2 EVO3 M3	GASKET CYL. TH.0,2 EVO3 M3
8	F05856.2	1	GUARNIZ.CIL/BAS SP.0,3 EVO3 M3	GASKET CYL. TH.0,3 EVO3 M3
8	F05856.3	1	GUARNIZ.CIL/BAS SP.0,4 EVO3 M3	GASKET CYL TH.0,4 EVO3 M3
8	F05856.4	1	GUARNIZ.CIL/BAS SP.0,5 EVO3 M3	GASKET CYL. TH.0,5 EVO3 M3
9	F49875	2	PRIGIONIERO M6X1 /=83 MM A10.9	STUD M 6X1 83MM
10	F49045	4	PRIGIONIERO M10X1,25 L=142,5	STUD M 10X1,25 142,5 MM
11	F12380.1	2	O RING ORM 89,0X2,0 VITON	O-RING 89 X 2
12	49676	2	DADO M 6X1 FLANG. AUTOBL.ACC.	NUT, FLANGED M6 X 1 S.B.

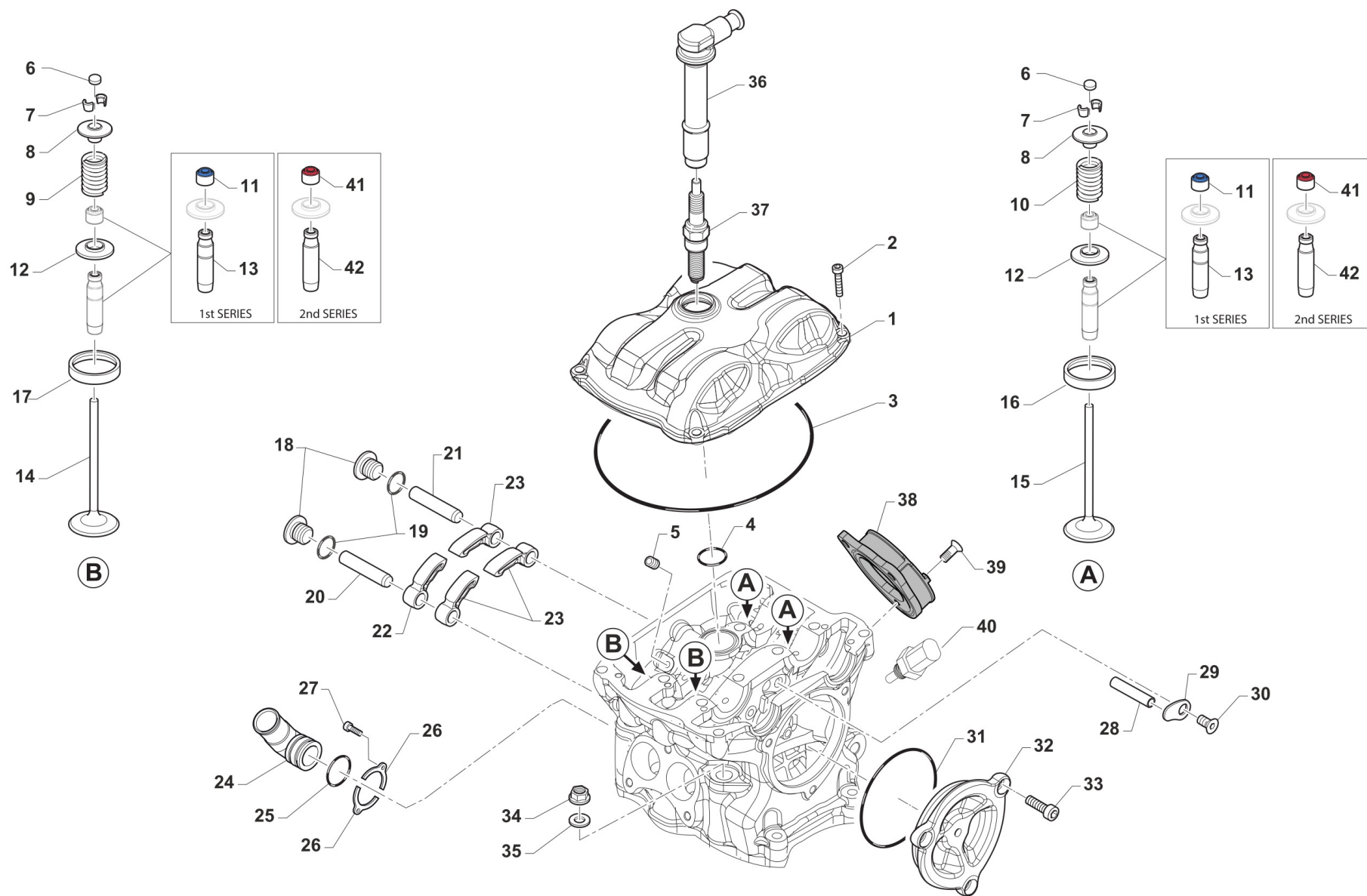

0002.01



**4T250FIMX21-M**  
**MOTORE - ENGINE**

**TESTA**  
**HEAD**

1	F30061	1	COPERCHIO TESTA 250Fi MX MY18	CYLINDER HEAD COVER 250Fi F.S. MX M18->
2	49482	4	VITE TCEI 6X14 UNI 5931	BOLT TCEI 6X14
3	F12364	1	O RING 155X2	O-RING 155 X 2
4	F12345.1	1	O RING ORM 24,0X1,5 VITON	O-RING 24 X 1,5
5	49702	1	GRANO 5X 6 VALV.SC.MARTELLETTO	GRUB SCREW 5 X 6 INLET VALVE
6	F26603.255	1	PASTIGLIA REGOLAZ. GIOCO Ø 7,26 Sp. 2,55	SHIM, VALVE ADJUSTING Ø 7,26 TH. 2,55
6	F26603.260	1	PASTIGLIA REGOLAZ. GIOCO Ø 7,26 Sp. 2,60	SHIM, VALVE ADJUSTING Ø 7,26 TH. 2,60
6	F26603.265	1	PASTIGLIA REGOLAZ. GIOCO Ø 7,26 Sp. 2,65	SHIM, VALVE ADJUSTING Ø 7,26 TH. 2,65
6	F26603.270	1	PASTIGLIA REGOLAZ. GIOCO Ø 7,26 Sp. 2,70	SHIM, VALVE ADJUSTING Ø 7,26 TH. 2,70
6	F26603.275	1	PASTIGLIA REGOLAZ. GIOCO Ø 7,26 Sp. 2,75	SHIM, VALVE ADJUSTING Ø 7,26 TH. 2,75
6	F26603.280	1	PASTIGLIA REGOLAZ. GIOCO Ø 7,26 Sp. 2,80	SHIM, VALVE ADJUSTING Ø 7,26 TH. 2,80
6	F26603.285	1	PASTIGLIA REGOLAZ. GIOCO Ø 7,26 Sp. 2,85	SHIM, VALVE ADJUSTING Ø 7,26 TH. 2,85
6	F26603.290	1	PASTIGLIA REGOLAZ. GIOCO Ø 7,26 Sp. 2,90	SHIM, VALVE ADJUSTING Ø 7,26 TH. 2,90
6	F26603.295	1	PASTIGLIA REGOLAZ.GIOCO Ø 7,26 Sp. 2,95	SHIM, VALVE ADJUSTING Ø 7,26 TH. 2,95
6	F26603.300	1	PASTIGLIA REGOLAZ. GIOCO Ø 7,26 Sp. 3,00	SHIM, VALVE ADJUSTING Ø 7,26 TH. 3,00
6	F26603.305	1	PASTIGLIA REGOLAZ. GIOCO Ø 7,26 Sp. 3,05	SHIM, VALVE ADJUSTING Ø 7,26 TH. 3,05
6	F26603.310	1	PASTIGLIA REGOLAZ. GIOCO Ø 7,26 Sp. 3,10	SHIM, VALVE ADJUSTING Ø 7,26 TH. 3,10
6	F26603.315	1	PASTIGLIA REGOLAZ. GIOCO Ø 7,26 Sp. 3,15	SHIM, VALVE ADJUSTING 7,26 TH. 3,15
6	F26603.320	1	PASTIGLIA REGOLAZ. GIOCO Ø 7,26 Sp. 3,20	SHIM, VALVE ADJUSTING 7,26 TH. 3,20
6	F26603.325	1	PASTIGLIA REGOLAZ. GIOCO Ø 7,26 Sp. 3,25	SHIM, VALVE ADJUSTING 7,26 TH. 3,25
6	F26603.330	1	PASTIGLIA REGOLAZ. GIOCO Ø 7,26 Sp. 3,30	SHIM, VALVE ADJUSTING 7,26 TH. 3,30
7	F14178	8	SEMICONO D.5 - 15^ HAYFIELD	VALVE RETAINER D.5 15^HAYFIELD
8	F26597	4	PIATTELLO SUP. MOLLA 250M3	UPPER PLATE
9	F16473	2	SET MOLLA EST. + MOLLA INT. SCAR.	EXTER. & INTER.SPRINGS EXHAUST
10	F16472	2	SET MOLLA EST. + MOLLA INT. ASP.	EXTER. & INTER.SPRINGS INLET
11	F04378	4	PARAOLIO VALVOLA 3242V COMETIC	OIL SEAL VALVE COMETIC 3242V
12	F26689	4	PIATTELLO T 24X4	LOWER PLATE
13	F26474	4	GUIDA VALVOLA d.5 SIN.S.METELL	GUIDE, VALVE 250Fi D.5



**4T250FIMX21-M**  
**MOTORE - ENGINE**

**TESTA**  
**HEAD**

14	F14158	2	VALVOLA SCA 250Fi 26.8x5 TIT	EXHAUST VALVE 250Fi TIT 26.8X5
15	F14164	2	VALVOLA ASP 250Fi 32x5 TIT	INLET VALVE d.35X5 250Fi TIT
16	F26557	2	SEDE VALVOLA ASP.250cc	
17	F26558	2	SEDE VALVOLA SCAR.250cc	
18	F49871	2	TAPPO ASSE ROT.BILANC.250 M3	PLUG
19	F12325	2	OR ORM 090-15 FILTRO ASP.OLIO 250N	O-RING
20	F28812	1	ASSE ROTAZIONE BIL.SCAR. 250M3	AXLE, ROCKER ARM EXHAUST
21	F28811	1	ASSE ROTAZIONE BIL.ASP.250M3LO	AXLE, ROCKER ARM INTAKE
22	F28836	1	FINGER FOLLOWER WITH DECOM.MIM	FINGER FOLLOWER WITH DECOM.MIM
23	F28835	3	FINGER FOLLOWER NO DECOMP. MIM	FINGER FOLLOWER NO DECOMP. MIM
24	F28841	1	RACCORDO USCITA ACQUA TESTA	JOINT, HEAD WATER
25	F12346.1	1	O RING ORM 18,0X2,0 VITON	O-RING 18 X 2
26	F48374	2	PIASTRINO RITEGNO RACCORDO H2O	PLATE
27	49553	2	VITE TCEI 4X8	BOLT TCEI 4X8
28	F28810	1	ASSE ROTAZIONE BIL.ASP.250M3LC	AXLE, ROCKER ARM INTAKE
29	F48371	1	PIASTRINO BATT.ASSE ROT.BIL.LC	PLATE
30	49396	1	VITE TSEI 5X10	BOLT TSEI 5X10
31	F12351.1	1	O RING ORM 61,6X2,4 VITON	O-RING 61,6 X 2,4
32	F30015	1	COPERCHIO ISP. TESTA 250Fi 250 REP.4T	COVER, HEAD, TWIN
33	49481	3	VITE TCEI 6X12	BOLT TCEI 6X12
34	F49874	4	DADO M 10 X 1,25 CH 12 FLANGIATO	NUT FLANGED M 10x1,25 T.12mm
35	F48400	4	RONDELLA Ø10xØ17,5x3	WASHER Ø10xØ17,5x3
36	F21436	1	PIPETTA CANDELA RESISTIVA 250 4T MY18->	CAP, SPARK PLUG
37	F06116	1	CANDELA NGK R0451B-8	SPARK PLUG NGK R0451B-8
38	F13287	1	COLLETTORE ASPIRAZIONE 250Fi 4T REPL.	INLET MANIFOLD 250Fi F.S. R.
39	49989	3	VITE TS 5X14 TORX	BOLT TORX 5 X 14
40	F08003	1	SENSORE TEMP. ACQUA WTS 09/02	SENSOR, WATER TEMPERATURE
41	F04388	4	ANELLO TENUTA STELO VALV.D.5mm SKF	





**4T250FIMX21-M**  
**MOTORE - ENGINE**

**TESTA**  
**HEAD**

42	F26728	4	GUIDA VALVOLA SINT. D.5 PER TENUTA SKF
----	--------	---	--

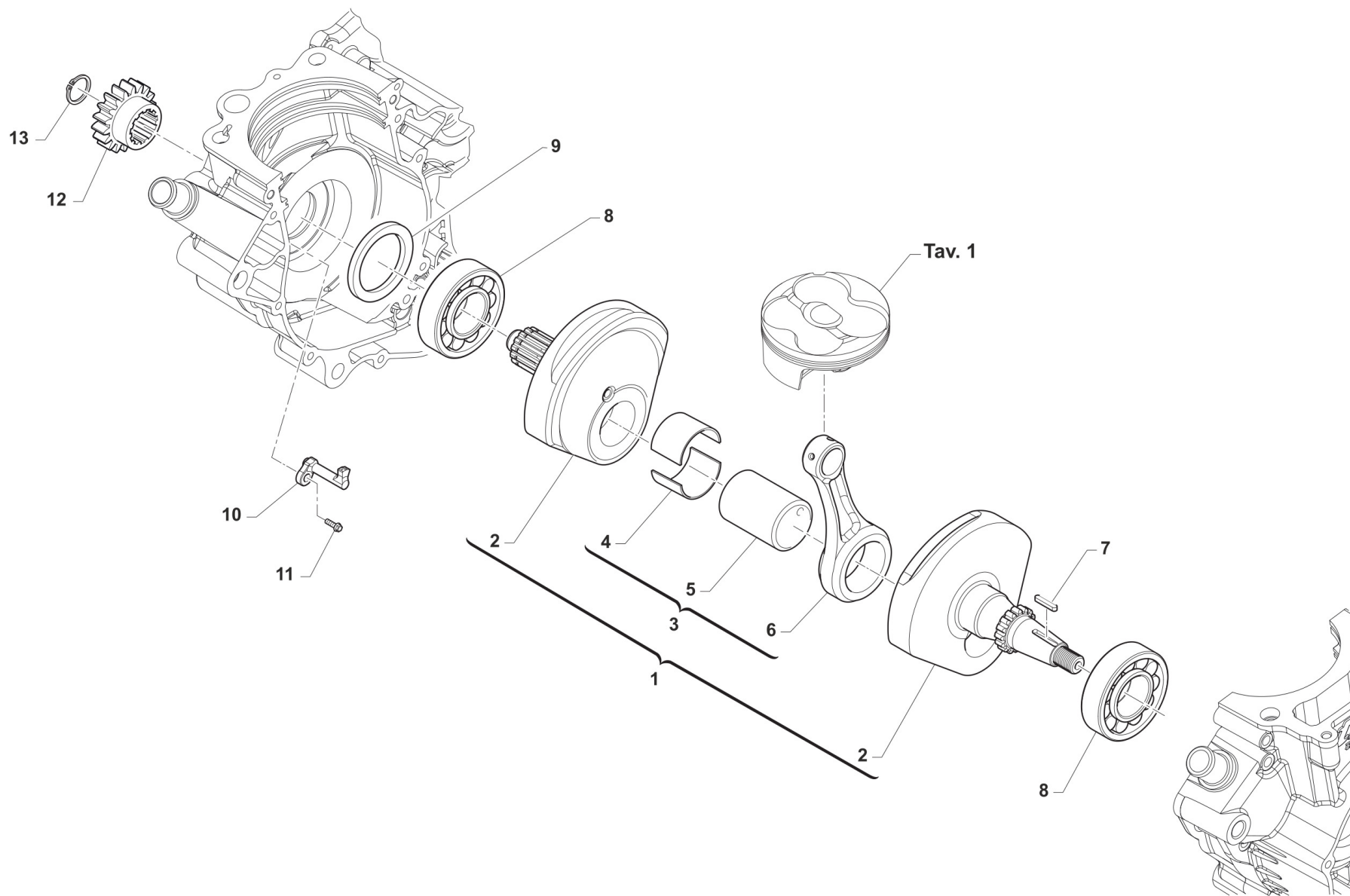



**4T250FIMX21-M**  
**MOTORE - ENGINE**

**MANOVELLISMO**  
**CRANKSHAFT**

**3**

1	F18109	1	K.S.	ALBERO MOTORE 250Fi KS CPL	
1	F18110	1	E.S.	ALBERO MOTORE 250Fi ES TWIN CPL	CRANKSHAFT ASSY 250Fi ES
2	F18121	1	K.S.	COPPIA SEMIALBERI 250Fi KS MY18	
2	F18122	1	E.S.	COPPIA SEMIALBERI 250Fi ES MY18	CRANKSHAFT SIDES
3	F18111	1		BIELLA 250Fi MX 4T 2018 CPL	CONROD ASSY 250Fi MX 4S M.18->
4	F03375.4	1		BRONZINA CP BIELLA 30X34X18 BB BLU/BLU	CONNECTING ROD BUSH ASSY 30x34x18 blu
4	F03375.5	1		BRONZINA CP BIELLA 30X34X18 RG ROSSO/GIALLO	BUSH ASSY 30x34x18 RED/YELLOW
5	F18059	1		ASSE ACCOPP. D.30X54,7 X BRONZ	
6	F18093	1		BIELLA D34XD.16 I.94.5 BR	
7	F49853	1		CHIAVETTA 5X3X25 UNI7510R.F.A.	WOODRUFF KEY, 5x3x25
8	03026	2		CUSCINETTO ALBERO MOTORE NJ206	BUSH, NJ206 CRANKSHAFT
9	F04375	1		PARAOLIO 25X35X4	
10	F32573	1		UGELLO RAFFREDDAMENTO	NOZZLE
11	49472	1		VITE TCEI 5X12 UNI 5931	BOLT TCEI 5X12
12	F40057	1		PIGNONE TRASM.PRIMARIA Z17 SCANAL.	
12	F40057.1	1		PIGNONE TRASM.PRIM.Z17 SC.PROV	
12	F40057.3	1		PIGNONE TRASM.PRIM.Z17	
13	49255	1		SEEGER RETTIFICATO CAMBIO 250	CIRCLIP, GEAR BOX 250cc

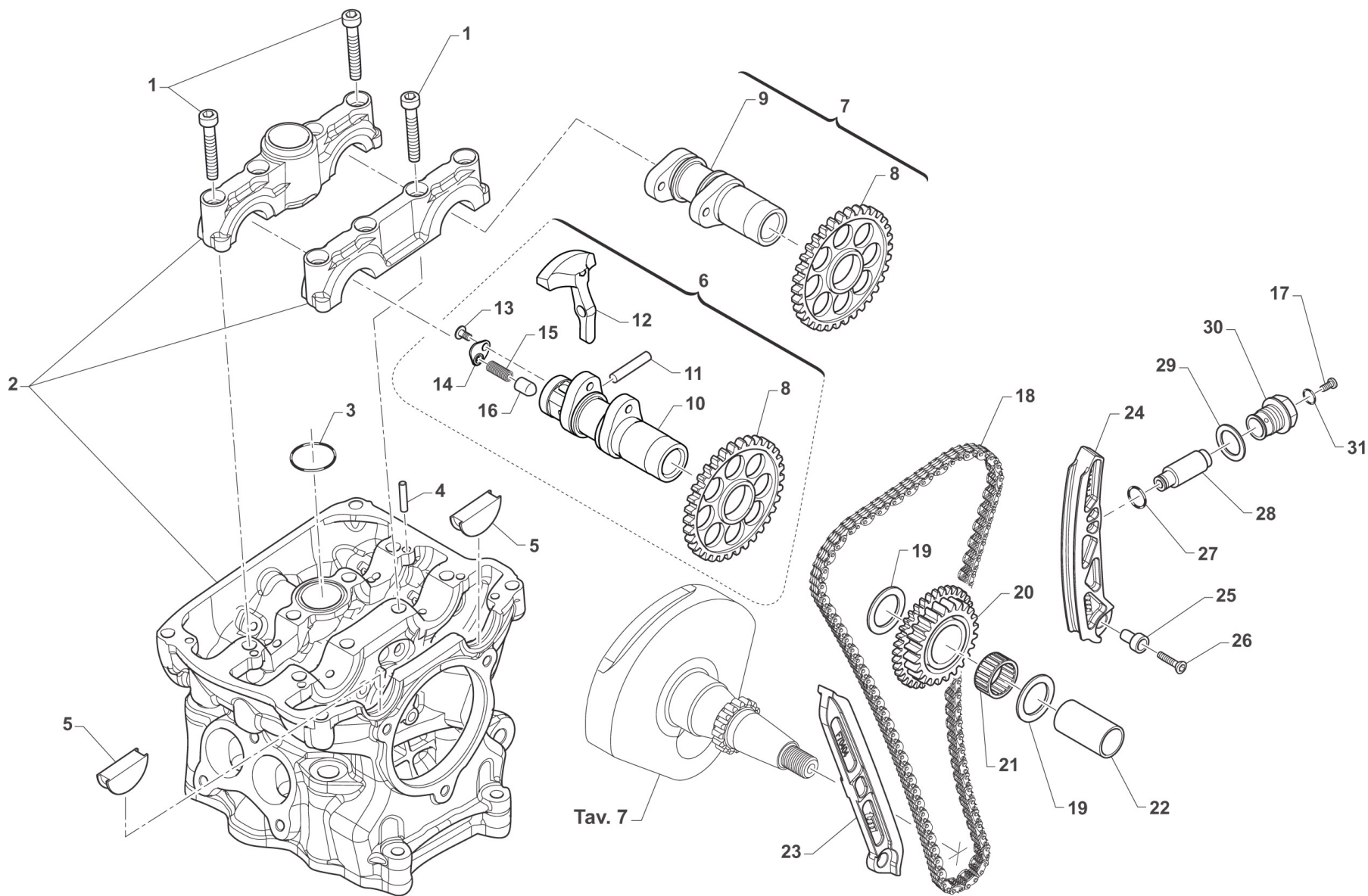

TM0004



**4T250FIMX21-M**  
**MOTORE - ENGINE**

**DISTRIBUZIONE**  
**VALVES COVER**

**4**

1	49487	8		VITE TCEI 6X35 UNI 5931	BOLT TCEI 6X35
2	F02887	1		TESTA 250Fi MX CPL M 18->	CYLINDER HEAD 250Fi F.S. MX M18->
3	F12344.1	1		O RING ORM 23,0X1,5 VITON	O-RING 23 X 1,5
4	F19529	4		RULLO D.4 X 10 TESTA BOMBATA" NRA"	PIN 4 X 10
5	F30060	2		COPERC.TTO FORI A.CAMME250/300	CAP, HOLE CAMSHAFT 250/300
6	F28845	1	K.S.	ALBERO A CAMME SCARICO 250Fi MX KS MY18 CPL	
6	F28852	1	E.S.	ALBERO A CAMME SCARICO 250Fi MX ES + EN CPL	CAMSHAFT ASSY, EX, 250 MX ES + EN
7	F28846	1		ALBERO A CAMME ASPIRAZIONE 250Fi MX 2018 CPL	
8	F40062	2		INGR. ALBERO A CAMME GEN. Z28	GEAR 28T, CAMSHAFT
9	F28807	1		ALBERO A CAMME ASP. EVO3 XA-18	
10	F28809	1		ALBERO A CAMME SCAR.EVO3 XS-04	CAMSHAFT EX XS-04
11	F19530	1		RULLO D.5 X 19.8 G2 0 -0.010	PIN 5 X 19,8
12	F26575	1		DECOMPRESSORE (MASSA CENT.) M3	DECOMPRESSOR
13	49597	1		VITE TBCEI 4 x 8 UNI 7380	BOLT TBCE 4 x 8
14	F48368	1		PIASTRINO GUIDA MOLLA DECOMPR.	PLATE DECOMPRESSOR SPRING 250 F.S.
15	F16466	1	K.S.	MOLLA DECOMPRESSORE 250cc 4T M3	DECOMPRESSION SPRING 250 FS M3
15	F16479	1	E.S.	MOLLA AZIONAMENTO DECOMP. D.0,3 250 4T REP.	SPRING
16	F26576	1		PISTONCINO ATTIVAZIONE DECOMP.	PISTON DECOMPRESSOR
17	F49871	1		TAPPO ASSE ROT.BILANC.250 M3	PLUG
18	F70422	1		CATENA DIST.MORSE 92RH2015 90P 250 TWIN	CAM CHAIN 82RH2015 90
19	F48372	2		RASAMENTO 18 x 30 x 0.8	SHIM 18 X 30 X 0,8
20	F40061	1		INGR. DOPPIO DISTRIBUZ.24/21	GEAR 24/21T DISTRIBUTION
21	F19526	1		GABBIA A RULLINI K 18X22X17	NEEDLE BUSH 18x22x17
22	F28813	1		ASSE ROTAZIONE INTR.18X42,7F13	PIN ROTATION GEAR 18x42,7 H.13
23	F70404	1		PATTINO FISSO 4T 250/300 TWIN	FIXED SLIDER
24	F70413	1		PATTINO MOBILE 4T 250/300 TWIN	MOVING SLIDER
25	F49883	2		BOCCOLA FISS. PATT.MOB. F70402	BUSH
26	49406	1		VITE TSEI 6X20	BOLT TSEI 6x20



**4T250FIMX21-M**  
**MOTORE - ENGINE**

**DISTRIBUZIONE**  
**VALVES COVER**

**4**

27	F12346.1	1	O RING ORM 18,0X2,0 VITON	O-RING 18 X 2
28	F70408	1	TENDITORE IDRAULICO 250 M3 F-346264.89-0100.KSH.KSYS	HYDRAULIC TENSIONER 250Fi M3
29	49949	1	RONDELLA RAME 24X30X1,5	WASHER, COPPER, 24 X 30 X 1,5
30	F49884	1	TAPPO TENSIONATORE IDR. M3	PLUG, TENSIONER
31	F12356.1	1	O RING ORM 10,0X1,0 VITON	O-RING 10 X 1

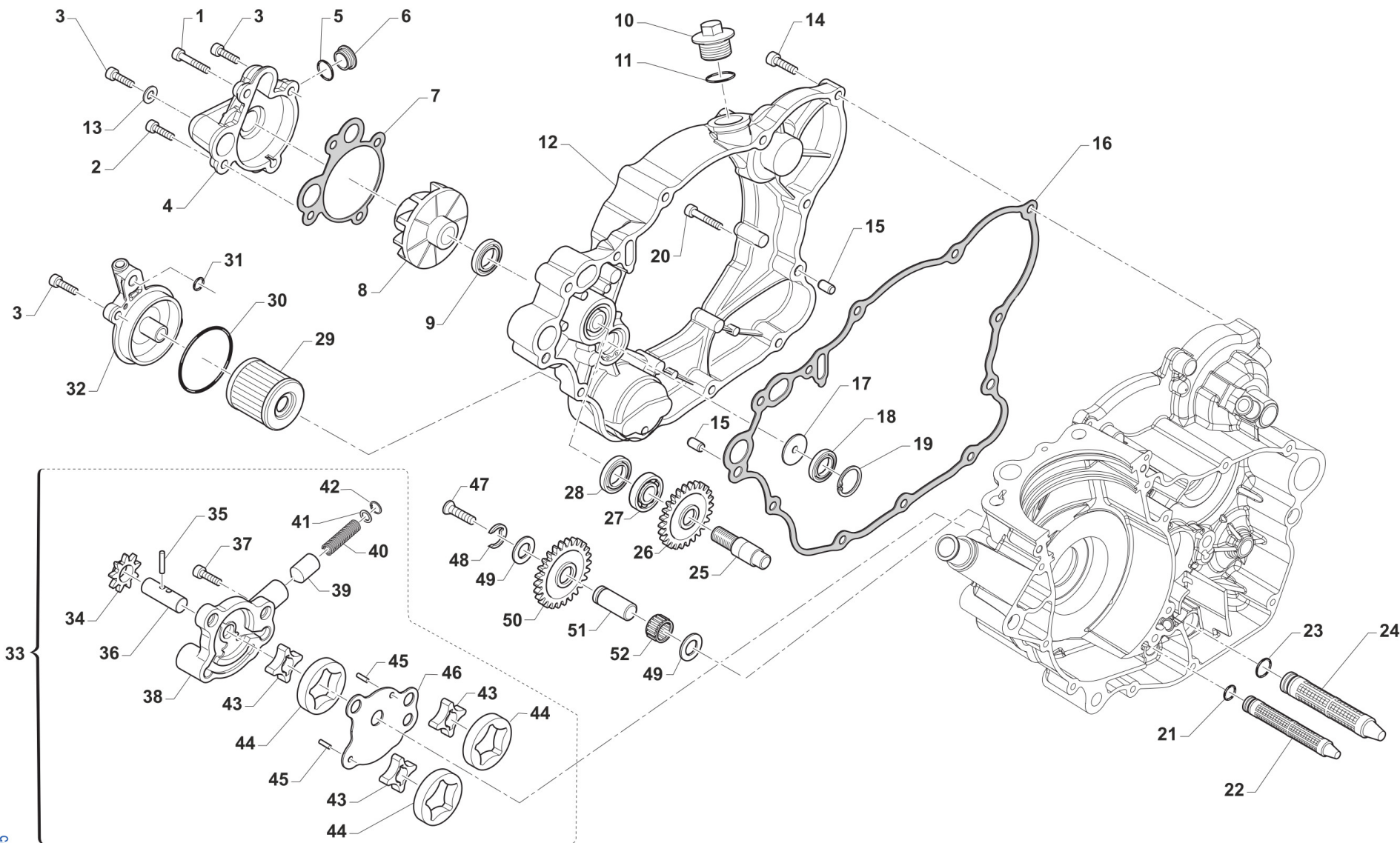

TM0005



**4T250FIMX21-M**  
**MOTORE - ENGINE**

**LUBRIFICAZIONE**  
**LUBRIFICATION**

1	49575	1	VITE TCEI 5X45 UNI 5931	BOLT TCEI 5X45
2	49570	1	VITE TCEI 5X50 UNI 5931	SCREW TCEI 5X50
3	49476	3	VITE TCEI 5X20 UNI 5931	BOLT TCEI 5X20
4	F30966	1	COPERCHIO POMPA H2O 250Fi 11/-	COVER, WATER PUMP 250Fi M.2011
5	F12327	1	O RING COPERCHIO P.ACQUA 250N	O-RING COVER WATER PUMP 250 4S
6	F49841	1	TAPPO COP. POMPA H2O 250Fi	CAP, COVER WATER PUMP 250 4S
7	F05833	1	GUARNIZ.COP.POMPA ACQUA.250N	GASKET, H2O COVER 250Fi
8	F28679	1	GIRANTE POMPA ACQUA 250N	IMPELLER, H2O PUMP 250Fi
9	04017	1	PARAOLIO CENTRIFUGA 06 +MF1TAG	OIL SEAL 8 X 22 X 7 TC
10	F49925	1	TAPPO CARICO OLIO M20X1.5	OIL PLUG M20X1,5
11	F49920	1	RONDELLA ALL 20.4X26X1.5	WASHER 20,4X26X1,5 ALUM.
12	F30961	1	COPERCHIO TRAS. PRIM. 250N '11	COVER, PRIMARY DRIVE 250N 11->
13	49119	1	RONDELLA 5 x 9 x 1,5 ALLUMINIO	WASHER, 5 x 9 x 1.5 ALLUMINIUM
14	49477	7	VITE TCEI 5X25 UNI 5931	BOLT TCEI 5X25
15	26041	2	GRANO CENTRAGGIO D.7X8 F.5,2	DOWEL PIN 7 x 8 Hole 5,2
16	F05828	1	GUARNIZ.COP.TRASM.PRIMAR.250N	GASKET, CLUTCH CASE 250Fi
17	F32529	1	DISCHETTO PARZIAL. MAND.OLIO 250N	DISC OIL PUMP 250 F.S.
18	F04390	1	PARAOLIO FAJ 14-22-5 HS	OIL SEAL FAJ 14-22-5 HS
19	F49913	1	SEEGER I 23	CIRCLIP INT. 23
20	49478	1	VITE TCEI 5X30 UNI 5931	BOLT TCEI 5X30
21	F12325	1	OR ORM 090-15 FILTRO ASP.OLIO 250N	O-RING
22	F32532	1	FILTRO ASPIRAZ.POMPE OLIO 250N	FILTER, OIL, 250Fi
23	F12343	1	O RING FILTRO OLIO 250F	O-RING
24	F32555	1	FILTRO ASPIRAZIONE OLIO MAGG.	FILTER OIL INLET
25	F28658	1	ALBERINO POMPA H2O 250N	SHAFT, WATER PUMP 250Fi
26	F40955	1	INGRAN. POMPA ACQUA Z20 250N	
27	F03365	1	CUSCINETTO POMPA ACQUA 250/09	BEARING WATER PUMP 250/09
28	F04363	1	PARAOLIO 8X22X5 250/09->	OIL SEAL 8x22x5 (250F/09)





**4T250FIMX21-M**  
**MOTORE - ENGINE**

**LUBRIFICAZIONE**  
**LUBRIFICATION**

29	F66510	1	FILTRO OLIO 4Tempi HF 141	OIL FILTER HF - 141
30	12094	1	O RING COP. FILTRO OLIO	O RING OIL FILTER COVER
31	F12302	1	O RING 108 PIOGGIA CAMBIO 4T	O-RING, 108 GEAR F.S.
32	F30965	1	COPERCHIO FILTRO OLIO 250Fi 11	CAP, OIL FILTER 250Fi 11->
33	F30068	1	POMPA OLIO COMPLETA 250/300 Fi TWIN	OIL PUMP ASSY
34	F40997	1	INGRANAGGIO POMPA OLIO 250Fi Z 9	GEAR, OIL PUMP 250Fi 9 T
35	F19513	3	RULLINO ING. POMPA 250/09	PIN, PUMP GEAR 250 09->
36	F28840	1	ALBERINO POM.OLIO RO.H10/2XH10	SHAFT, OIL PUMP
37	49751	2	VITE TCEI 5X22	BOLT TCEI 5 X 22
38	F30059	1	CORPO POMPA	OIL PUMP BODY
39	F32533	1	PIST.NE VALV.LIMIT.PRESS.OLIO	PISTON
40	F16441	1	MOLLA VALVOLA PRESS.OLIO 250N	SPRING
41	49600	1	RONDELLA 4x8x0,8	WASHER 4
42	49267	1	SEEGER 8mm INT Sp. 0,8	SEEGER
43	F32577	3	ROTORE INTERNO POMPA OLIO 250Fi	ROTOR, OIL PUMP, INTERNAL
44	F32578	3	ROTORE ESTERNO POMPA OLIO 250Fi	ROTOR, OIL PUMP, EXTERNAL
45	F19521	2	RULLINO D.3 X 11	PIN 3 X 11
46	F32574	1	SEPARATORE POMPA OLIO	PLATE
47	49429	1	VITE TSEI 4X35	BOLT TSEI 4X35
48	F49821	1	SEEGER ING. FOLLE P.OLIO 250/09	SEEGER INTER.GEAR OIL P.250 4S
49	F19512	2	RALLA ING.FOLLE P. OLIO 250/09	THRUST WASHER
50	F40909	1	INGR. OZIOSO POMPA OLIO 250N	GEAR, OIL PUMP
51	F28665	1	ALBERINO ING.FOLLE P.OLIO 250N	SHAFT
52	F19511	1	GABBIA RULLI ING.F.P.OL.250/09	NEEDLE CAGE GEAR 250F 09->

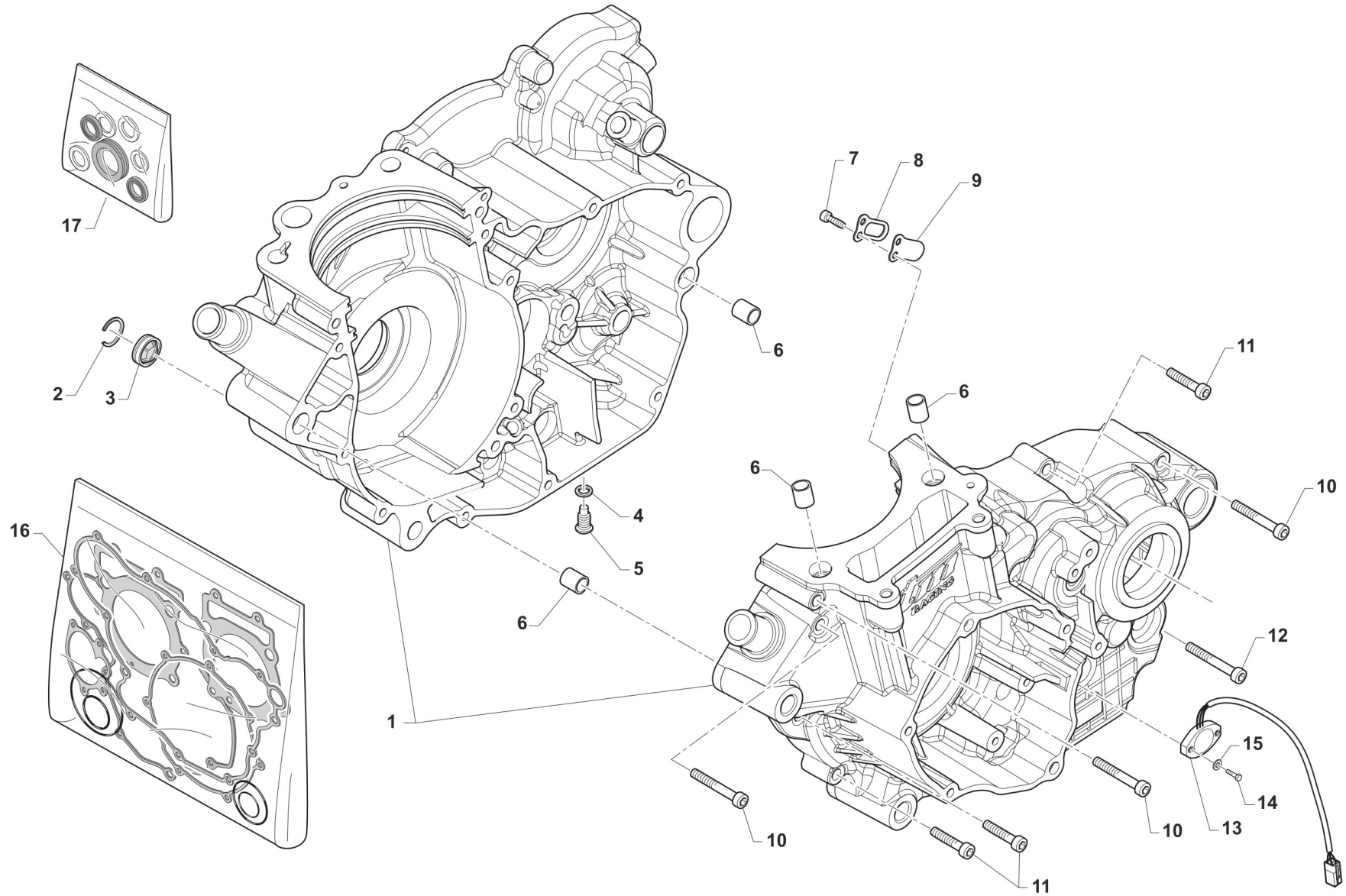

TM0006



**4T250FIMX21-M**  
**MOTORE - ENGINE**

**CARTER MOTORE**  
**CLUTCH CASE**

1	F30069	1	K.S.	BASAMENTO MOTORE 250Fi KS	
1	F30070	1	E.S.	BASAMENTO MOTORE 250Fi ES	CRANKCASE, 250Fi 4S ES
2	F49832	1		SEEGER SB25 OBLO' 250Fi 10/->	SEEGER
3	F04366	1		OBLO' LIVELLO OLIO DIAM.25 MM	OIL LEVEL INSPECTION SIGHT GLASS
4	49125	2		RONDELLA 12X18X1,5 ALLUMINIO	WASHER 12X18X1,5 AI
5	F49820.1	2		TAPPO OLIO C/CALAM. 250Fi	OIL PLUG WITH MAGNET 250Fi
6	F26428	4		GRANO RIFERIMENTO 12X13 F10.2	GRUB SCREW 12X13 H.10,2mm
7	49542	1		VITE TCEI 5X10 UNI 5931	BOLT TCEI 5 X 10
8	F20004	1		STOPPER LAMELL.CAMERA ALB.250N	STOPPER, STOP
9	F20003	1		LAMELLA SFIATO PRESS.250Fi	REED
10	49491	3		VITE TCEI 6X55	BOLT TCEI 6X55
11	49487	4		VITE TCEI 6X35 UNI 5931	BOLT TCEI 6X35
12	49492	1		VITE TCEI 6X60	BOLT TCEI 6X60
13	F08236.1	1		SENSORE POSIZ.CAMBIO RFD-4021 CABLATO	SENSOR GEAR POSITION RFD-4021 W/WIRE
14	49922	2		VITE TE 3X14	
15	49926	2		RONDELLA 3X9X1	WASHER 3 X 9 X 1
16	F05863	1		KIT GUARNIZIONI 250Fi MX 18/21 EN 19/21 TWIN	GASKET KIT 250Fi MX 18/21 EN 19/21 TWIN
17	F04389	1		KIT PARAOLI 4T 250Fi MX MY 18/->	OIL SEAL, SET, 4S 250Fi MX MY 18/-> 300Fi MX MY 2019

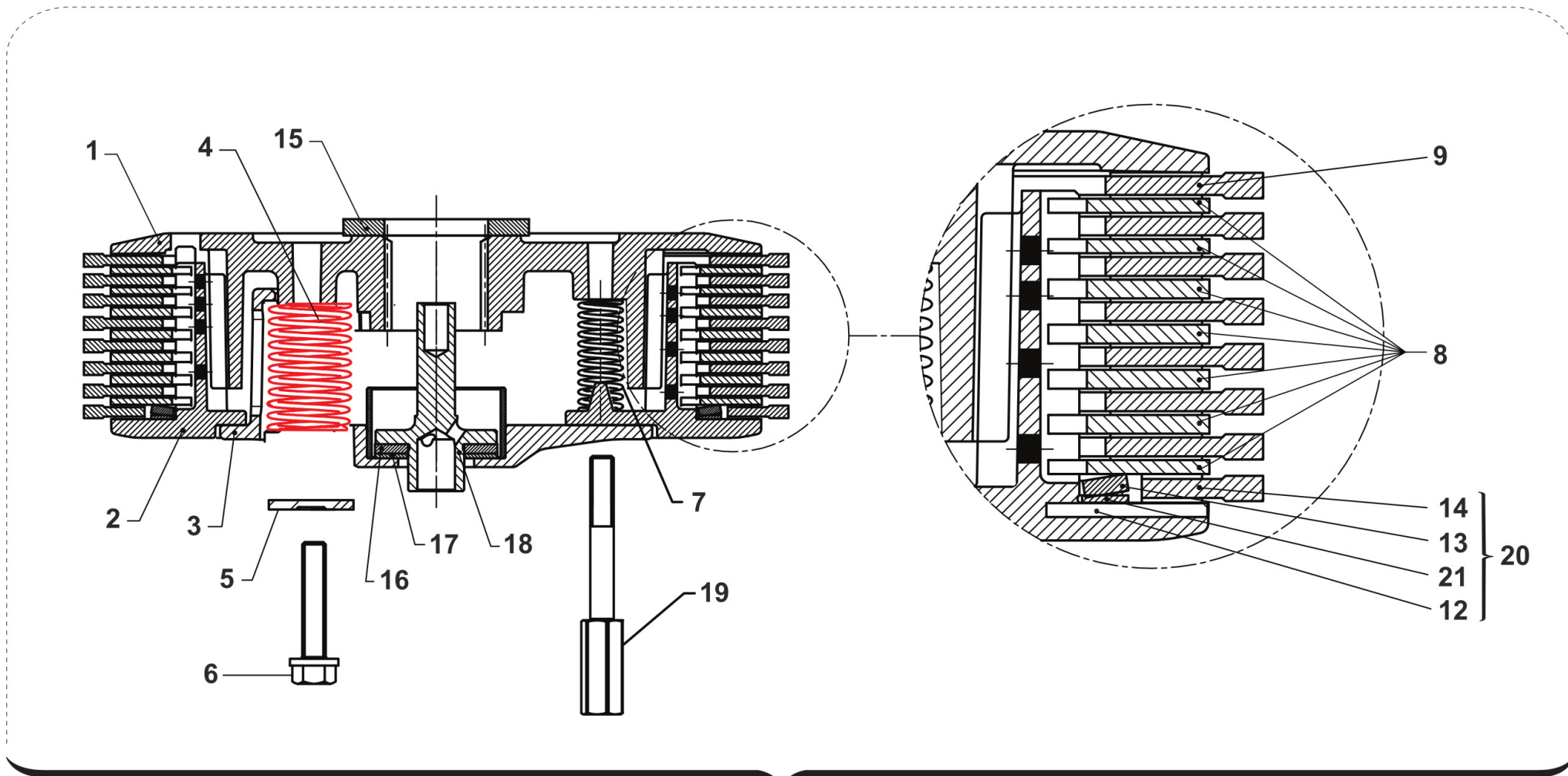



4T250FIMX21-M  
MOTORE - ENGINE

FRIZIONE ADLER

1	F35572	1	MOZZO FISSO APTC ADLER 250Fi	
3	F35564	4	MOLLA PIAT.S.D. APTC ADLER 250	
3	F35573	1	PIATTO SPINGIDISCO ADLER 250Fi	
5	F35583	3	RONDELLA 5,5X20X1,5 Fe APTC	
6	F35585	3	VITE M5X25 SP. APTC 250/450	
7	F35537	3	MOLLA CONTRASTO A.S.ADLER (RC)	
8	35297	7	DISCO ACCIAIO SP.1,6mm 250 4TA (234 M 78)	
9	F35588	7	DISCO FRIZIONE 250Fi 4T FCC	CLUTCH PLATE, FIBER 250Fi 4S
10	F35556	1	FRIZIONE ANTISALT.ADLER 250cc	
12	F35586	1	DISCO CONDOTTO NITRURATO APTC	
13	F35562	1	MOLLA A TAZZA APTC ADLER 250cc	
14	F35561	1	DISCO TORNITO APTC ADLER	
15	48250	1	SPESSORE COPPIA PRIMARIA 250	SPACER, PRIMARY GEAR 250cc
16	19058	1	GABBIA A RULLI ASS. AXK 1226	NEEDLE CAGE AXK 1226
17	19059	1	RALLA GABBIA RULLI AS 1226	
18	F35580	1	PUNTALINO APTC ADLER 8868	PIN FOR APTC ADLER 8868
19	F35584	3	VITE M5X35 APTC 250/450	SCREW M5x35 APTC 250 / 450
20	ND	1	NON DISPONIBILE	TEMPORARILY NOT AVAILABLE
21	ND	1	NON DISPONIBILE	TEMPORARILY NOT AVAILABLE

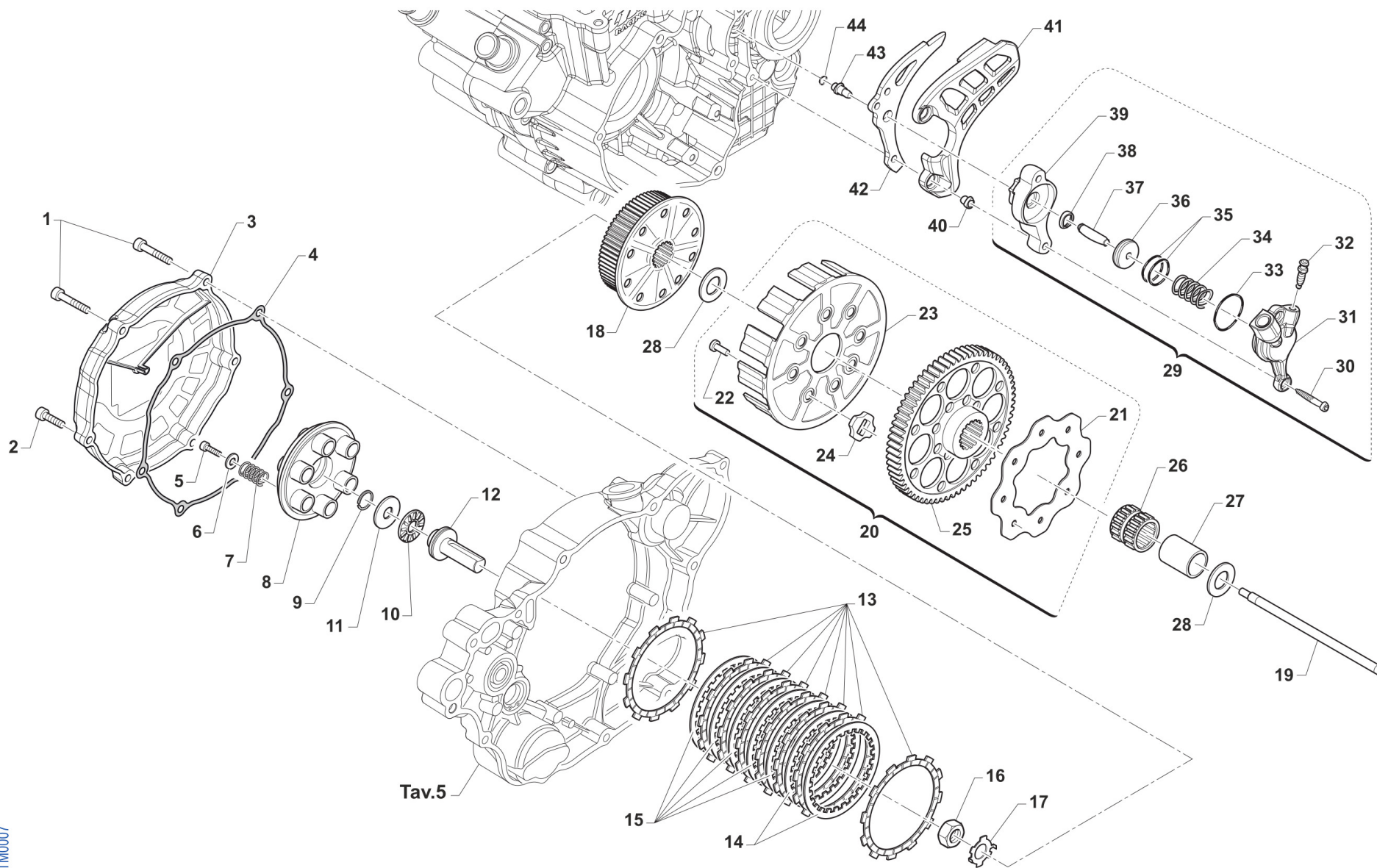



**4T250FIMX21-M**  
**MOTORE - ENGINE**

**FRIZIONE**  
**CLUTCH**

1	49736	2	VITE TCEI 5X65	BOLT TCEI 5X65
2	49477	4	VITE TCEI 5X25 UNI 5931	BOLT TCEI 5X25
3	F30960	1	COPERCHIETTO FRIZ.250Fi M.11->	COVER, CLUTCH 250Fi M. 11/->
4	F05841	1	GUARN. COP. FRIZ. 250Fi 2011	GASKET, CLUTCH COV 250Fi 11/->
5	49484	6	VITE TCEI 6X20	BOLT TCEI 6X20
6	49604	6	RONDELLA 6 X18 X 1,6	WASHER 6x18
7	F16453	6	MOLLA FRIZIONE 2/4T 250/450	SPRING, CLUTCH 2/4T 250/450
8	F25258	1	PIATTO SPINGIDISCHI 250Fi	PRESSURE PLATE, CLUTCH 250Fi
9	09006	1	ANELLINO FERMA SPINOTTO 80/85/100	CLIP, PISTON PIN 80/85/100cc
10	19022	1	GABBIA A RULLI RAD. AXK 1528	BUSH CAGE AXK 1528, RADIAL
11	19023	1	RONDELLA GABBIA RULLI AS 1528	WASHER, NEEDLE CAGE AS 1528
12	F35582	1	FUNGO FRIZIONE IDRAULICA 2015	PIECE, CLUTCH LIFTER
13	F35588	8	DISCO FRIZIONE 250Fi 4T FCC	CLUTCH PLATE, FIBER 250Fi 4S
14	F35596	2	DISCO FRIZ. ACC 1,8 mm 250Fi	CLUTCH DISC STEEL 1,8 mm 250Fi
15	F35541	5	DISCO FRIZ. ACC 1,5 mm 250N	CLUTCH PLATE, STEEL 1,5 250Fi
16	49060	1	DADO TAMBUR.FRIZ. ALB.PRIM. 250/300 M18X1.5	NUT, CLUTCH CENTER 250cc
17	35050	1	RONDELLA X FRIZ. 250/300/4T	CLUCTH WASHER 250/300/F
18	F25256	1	TAMBURELLO FRIZ.250F -N-	CLUTCH CENTER 250Fi
19	F35544	1	ASTINA CENTRAL.FRIZ.192mm 250N	ROD, CLUTCH 192mm 250N
20	F40038	1	COPPIA PRIMARIA CPL 250Fi z60	
21	35262	1	DISCO BATTUTA GOMMINI FRIZ. 2T/4T F.6 MM	PLATE, CLUTCH BASKET 250cc
22	49202	8	CHiodo FRIZIONE K3/KV/K7 D 5,8	PIN CLUTCH K3/KV/K7/K8/K9
23	F25257	1	CAMPANA FRIZ. 250Fi	CLUTCH BASKET 250Fi M. 10/->
24	21005	8	GOMMINO PARASTRAPPI FRIZIONE	RUBBER, CLUTCH BASKET
25	F40954	1	COPPIA PRIMARIA Z60/18 250N	
26	F19510	1	GABBIA A RULLINI K 27X32X23.8	NEEDLE CAGE 27 x 32 x 23.8
27	F26422	1	BOCCOLA INGR.TRASM.PRIM. 250N	BUSH, PRIMARY GEAR 250Fi
28	48250	2	SPESSORE COPPIA PRIMARIA 250	SPACER, PRIMARY GEAR 250cc



**4T250FIMX21-M**  
**MOTORE - ENGINE**

**FRIZIONE**  
**CLUTCH**

29	F30005	1	COP. FRIZ/IDR 4T 250N D.26 CPL	COVER, IDR/CLUTCH 4S 250N ASSY
30	49535	2	VITE TCEI 5X35 UNI 5931	BOLT TCEI 5X35
31	F30006	1	CORPO CILIN. FRIZ. 250Fi D.26	BODY CLUTCH CYLINDER 250Fi D26
32	35264	1	VITE SPURGO OLIO FRIZ.IDR.6X1	SCREW AIR BLED HYDRAUL.CLUTCH
33	12252	1	O RING PIGNONE CAT.+DIS.AL.MOT	O-RING, 25,12 x 1,78
34	F16445	1	MOLLA PIST. FRIZ. 250N CONICA	SPRING
35	12259	2	O RING PISTONE FR.125/250VERDE	O-RING, CLUTCH PISTON 125/250
36	F35522	1	PISTONE CILINDRETTO 250N D.26	PISTON CLUTCH CYLINDER 250F 26
37	F19518	1	RULLO D.S. 5 X 24	PIN 5 X 24
38	F04367	1	PARAOLIO 9X13X3	OIL SEAL 9X13X3
39	F35523	1	DISTANZIALE CILINDRETTO 250N	SPACER CYLINDER 250N
40	26211	2	BOCCOLA PROT. PIGNONE 250 F.5	COLLAR, SPROCKET 250cc H.5
41	F30944	1	PROTEZIONE PIGNONE 250Fi PLAST	SPROCKET PROTECTION 250 F.I. PLAST.
42	F70370	1	PROTEZ. ERGAL PIGN. CAT 250N	PROTECTION, ALUMINIUM, FRONT SPROCKET
43	F26460	1	DIST.CENTR.SUPP.ATT.FRIZ.250N	SPACER
44	F12302	1	O RING 108 PIOGGIA CAMBIO 4T	O-RING, 108 GEAR F.S.



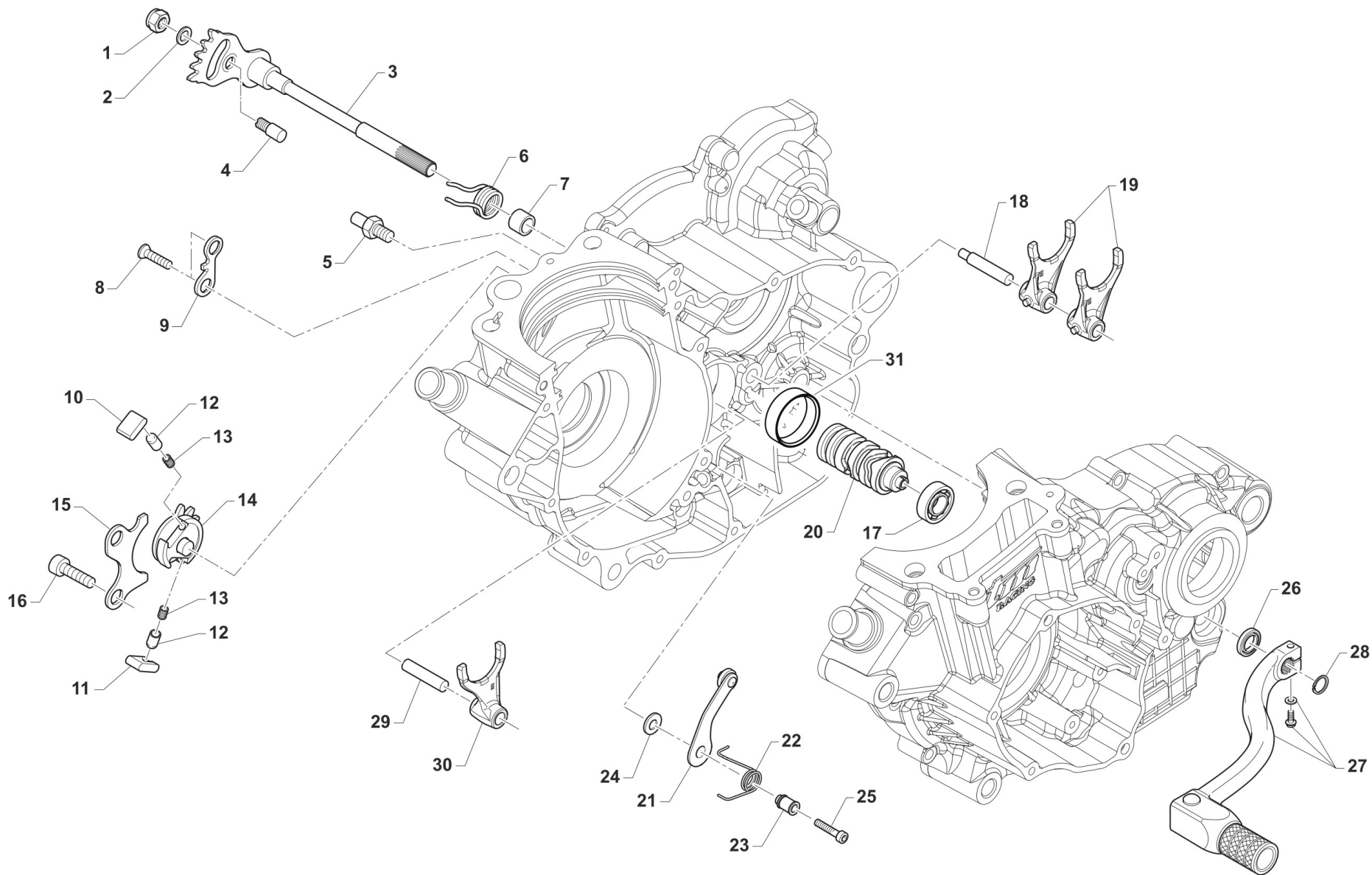



**4T250FIMX21-M**  
**MOTORE - ENGINE**

**COMANDO CAMBIO**  
**GEARSHIFT MECHANISM**

1	49638	1		DADO M 6 ALTO AUTOBLOCCANTE	NUT 6mm, HIGHT SELF-LOCKING
2	49603	1		RONDELLA M 6,4 X 12 X 1,6	WASHER 6x12
3	28100	1		ALBERO COMANDO ING. P.TACRIC.	SHAFT, GEARSHIFT
4	26050	1		BATTUTA ECCENTRICA	ADJUSTER SELECTOR SHAFT
5	F26455	1		BATTUTA FISSA MAN.CAMBIO 250N	
6	16010	1		MOLLA RITORNO LEVA CAMBIO 3	SPRING, RETURN GEAR LEVER 3mm
7	26006	1		DISTANZIALE MOLLA LEVA CAMBIO	SPACER, GEAR LEVER SPRING
8	49405	2		VITE TSEI 6X20 UMB.5933 10.9	BOLT TSEI 6x20 U.5933 10.9
9	F26454	1		PIASTR.FINECORSA CRIC. 250N	PLATE, ENDSTROKE RATCHET 250N
10	26060	1		CRICCHETTO CAMBIO SUPERIORE	RATCHET UP, GEAR
11	26061	1		CRICCHETTO CAMBIO INFERIORE	RATCHET DOWN, GEAR
12	26062	2		PUNTALE PER CRICCHETTO CAMBIO	PIN, RATCHET GEAR
13	16012	2		MOLLA PER PUNTALE	SPRING, GEARBOX PIN
14	40310	1		INGRANAGGIO PORTACRICCHETTI	DRUM SHIFTER GEAR
15	26021	1		PIASTRINO RIENTRO CRICCHETTI	PLATE, RATCHET
16	49483	2		VITE TCEI 6X16 UNI 5931	BOLT TCEI 6X16
17	03012	1		CUSCINETTO DESMODROMICO 6001 2RS	BUSH, 6001 2RS GEAR DRUM
18	33256	1		PERNO FORCH.ALB.SEC. 250 / 125.99	AXEL, COUNTERSHAFT FORK 250cc
19	F33312	2		FORCHETTA A/S 250Fi CROMATA	SHIFT FORK COUNTERSHAFT 250 4S
20	F33329	1	PER CAMBIO 6M	ALBERO DESMO 6M 250N INT.P.CPL CPL DI F26476 + MAGNETE	CAM, GEAR SHIFT
20	F33330	1	PER CAMBIO 5M	ALBERO DESMO COMPLETO 5M 250	
21	F26479	1		PIASTRINO BLOCCA MAR. 250Fi 12	PLATE, STOP GEAR 250 4S 12->
22	F16447	1		NON UTILIZZARE !!! MOLLA BLOCCA MARCE 250Nsostituita da F16447.3	SPRING, STOP GEAR 250 4S
23	26007	1		DISTANZIALE MOLLA BLOCCAMARCE	SPACER, STOP GEAR SPRING
24	49604	1		RONDELLA 6 X18 X 1,6	WASHER 6x18
25	49485	1		VITE TCEI 6X25 UNI 5931	BOLT TCEI 6x25
26	04004	1		PARAOLIO POMPA H2O-LEVA CAMBIO	OIL SEAL 12 x 22 x 5



**4T250FIMX21-M**  
**MOTORE - ENGINE**

**COMANDO CAMBIO**  
**GEARSHIFT MECHANISM**

27	43048	1	LEVA CAMBIO 2014 + 12MM (253) 85/125/144 2T 250Fi	GEAR LEVER 2014 +12mm
28	49212	1	SEEGER E12 LEVA CAMBIO	CIRCLIP D.12 - EXTERNAL
29	33255	1	PERNO FORCH.ALB. PRIM.250 / 125.99	AXEL, MAINSHAFT FORK 250cc
30	F33311	1	FORCHETTA A/P 250Fi CROMATA	FORK, SECONDARY SHAFT
31	19041	1	ASTUCCIO A RULLI DHK 35/12	BUSH NEEDLE CAGE DHK 35/12

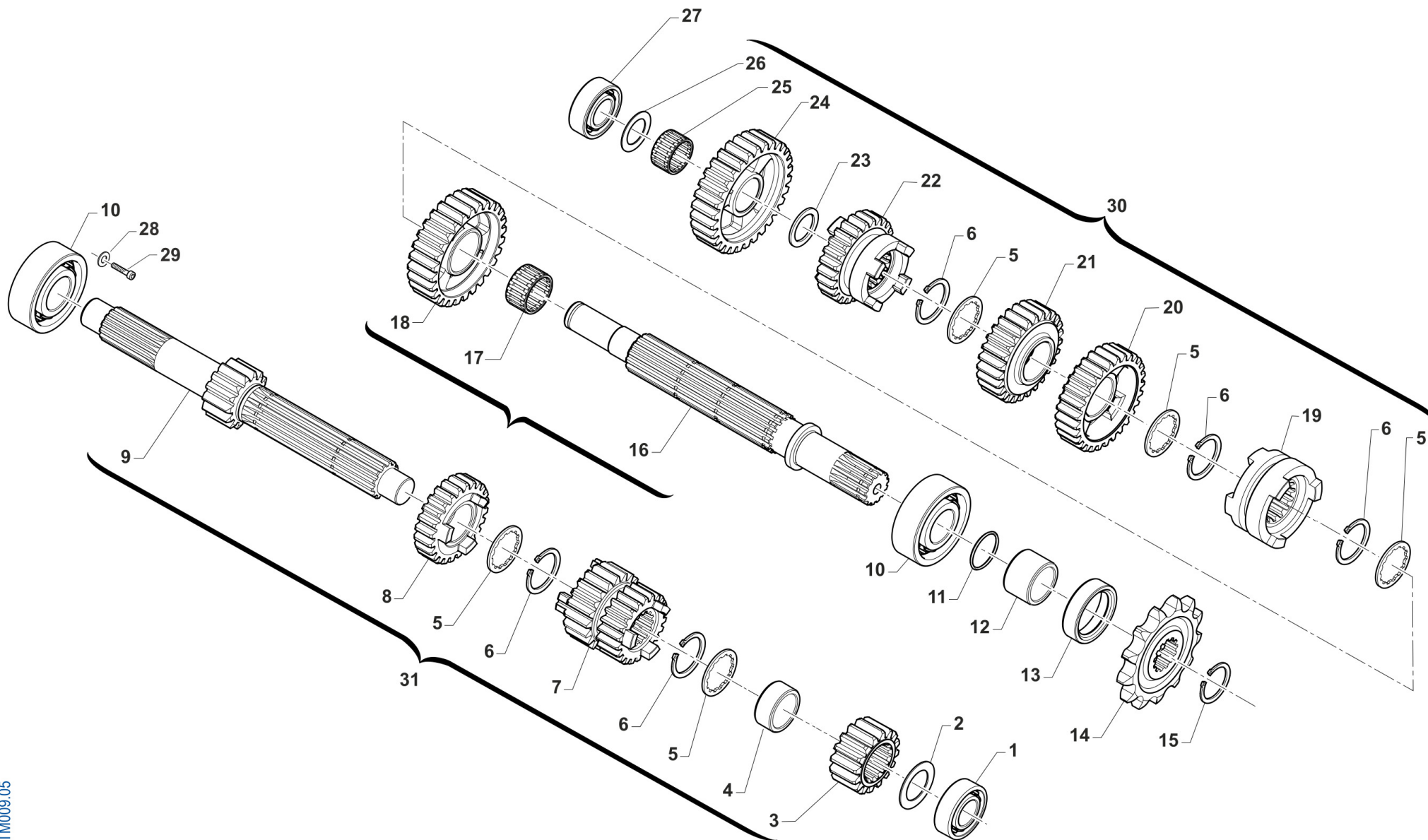



**4T250FIMX21-M**  
**MOTORE - ENGINE**

**CAMBIO 5 MARCE**  
**5 GEARS GEARBOX**

1	03254	1	CUSCINETTO A.P.4 Tempi 2RS1/C3	BUSH, MAINSHAFT 2RS/C3 4S
2	48253	1	SPESSORE CAMBIO 17X30X1 250	SPACER, GEAR BOX 250cc 17X30X1
3	F40894	1	INGR.2a VEL. Z16 A.P. 250N	GEAR 2 16T MAINSHAFT 250N
4	F26491	1	DIST.CAMBIO 250Fi 5 MARCE	
5	F40896	5	RALLA BROCCIATA Z14 250N	SHIM GEAR Z14 250 N
6	F49838	5	SEEGER E25 SPECIALE CAMBIO	SEEGER E25
7	F40895	1	INGR.3a/4a VEL.Z20/22 A.P.250N	GEAR 3/4 20/22T MAINSHAFT 250N
8	F40897	1	INGR.5a VEL.Z24 A.P. 250N	GEAR 5TH 24T, PRIMARY
9	F40893	1	ALBERO PRIMARIO Z14 250N	PRIMARY SHAFT 14T 250Fi
10	F03368	2	CUSCINETTO 62/22 C3 22x50x14	BUSH, 62/22 C3 22x50x14
11	F12320	1	O RING BOCCOLA PIGNONE 250/09	O-RING NBR 2087
12	F26421	1	DISTANZ. PIGNONE CATENA 250N	SPACER SPROCKET CHAIN 250N
13	04113	1	PARAOLIO 28X38X7 125TAG	OIL SEAL 28 x 38 x 7
14	F40889	1	PIGNONE CATENA 250N - Z13	SPROCKET 13T, DRIVE 250Fi
14	F40933	1	PIGNONE CATENA 250N - Z14	SPROCKET 14T, DRIVE 250Fi
14	F40956	1	PIGNONE CATENA 250N - Z12	SPROCKET 12T, DRIVE 250Fi
15	49217	1	SEEGER E22 ANELLO ALB/S	CIRCLIP D.22 - COUNTERSHAFT
16	F40899	1	ALBERO SECONDARIO 250N	SECONDARY SHAFT
17	F19524	1	GABBIA A RULLI 22X26X10 TAGL.	NEEDLE BEARING 22 X 26 X 10
18	F40901	1	INGR.2a VEL. Z28 A.S. 250N	GEAR 2 28T COUNTERSHAFT 250N
19	F40949	1	INNNESTO SCORREVOLE 2^/3^ VEL.	
20	F40902	1	INGR.3a VEL. Z29 A.S. 250N	GEAR 3 29T COUNTERSHAFT 250N
21	F40903	1	INGR.4a VEL. Z27 A.S. 250N	GEAR 4 27T COUNTERSHAFT 250N
22	F40904	1	INGR.5a VEL. Z25 A.S. 250N	GEAR 5th 25T COUNTERSHAFT 250N
23	F48353	1	SPESSORE PS 18X25X1	SPACER
24	F40900	1	INGR.1a VEL. Z30 A.S. 250N	GEAR, 1ST (30T) COUNTERSHAFT
25	F19514	1	GABBIA A RULLI 18X22X10	NEEDLE CAGE 18X22X10
26	48012	1	RASAMENTO A/S M/M SPESS.0,5	SPACER, 26x17x0,5



**4T250FIMX21-M**  
**MOTORE - ENGINE**

**CAMBIO 5 MARCE**  
**5 GEARS GEARBOX**

27	F03367	1	CUSCINETTO 6003 TN9C3 17x35x10	BUSH, 6003 TN9 C3 17x35x10
28	49603	1	RONDELLA M 6,4 X 12 X 1,6	WASHER 6x12
29	49480	1	VITE TCEI 6X10 UNI 5931	BOLT TCEI 6X10
30	F40968	1	ALBERO SEC.250Fi 5 MARCE CPL	
31	F40967	1	ALBERO PRIM.250Fi 5 MARCE CPL	

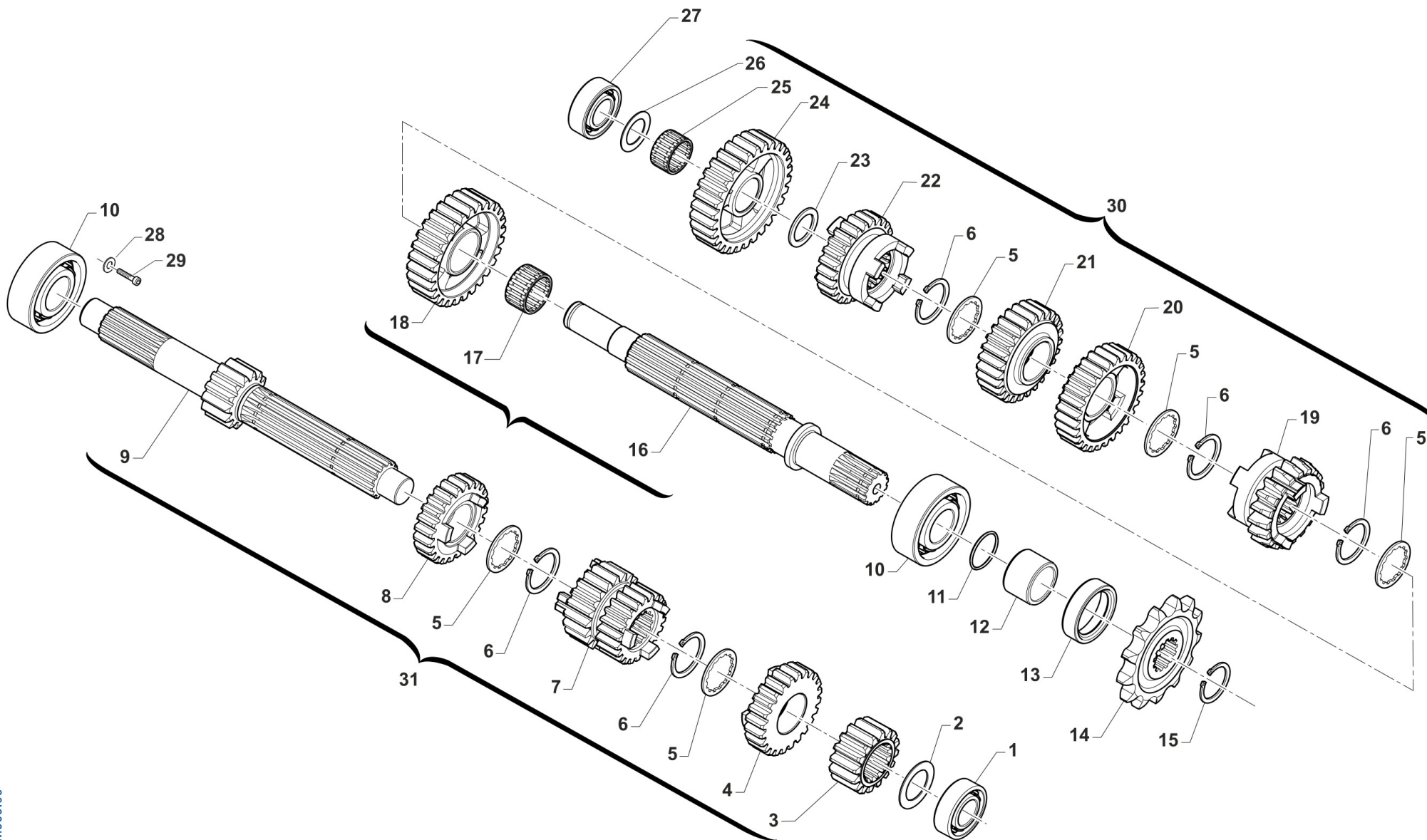



**4T250FIMX21-M**  
**MOTORE - ENGINE**

**CAMBIO 6 MARCE**  
**6 GEARS GEARBOX**

**10**

1	03254	1	CUSCINETTO A.P.4 Tempì 2RS1/C3	BUSH, MAINSHAFT 2RS/C3 4S
2	48253	1	SPESSORE CAMBIO 17X30X1 250	SPACER, GEAR BOX 250cc 17X30X1
3	F40894	1	INGR.2a VEL. Z16 A.P. 250N	GEAR 2 16T MAINSHAFT 250N
4	F40898	1	INGR.6a VEL.Z20 A.P. 250N	GEAR 6TH 20T, PRIMARY
5	F40896	5	RALLA BROCCIATA Z14 250N	SHIM GEAR Z14 250 N
6	F49838	5	SEEGER E25 SPECIALE CAMBIO	SEEGER E25
7	F40895	1	INGR.3a/4a VEL.Z20/22 A.P.250N	GEAR 3/4 20/22T MAINSHAFT 250N
8	F40897	1	INGR.5a VEL.Z24 A.P. 250N	GEAR 5TH 24T, PRIMARY
9	F40893	1	ALBERO PRIMARIO Z14 250N	PRIMARY SHAFT 14T 250Fi
10	F03368	2	CUSCINETTO 62/22 C3 22x50x14	BUSH, 62/22 C3 22x50x14
11	F12320	1	O RING BOCCOLA PIGNONE 250/09	O-RING NBR 2087
12	F26421	1	DISTANZ. PIGNONE CATENA 250N	SPACER SPROCKET CHAIN 250N
13	04113	1	PARAOLIO 28X38X7 125TAG	OIL SEAL 28 x 38 x 7
14	F40889	1	PIGNONE CATENA 250N - Z13	SPROCKET 13T, DRIVE 250Fi
14	F40933	1	PIGNONE CATENA 250N - Z14	SPROCKET 14T, DRIVE 250Fi
14	F40956	1	PIGNONE CATENA 250N - Z12	SPROCKET 12T, DRIVE 250Fi
15	49217	1	SEEGER E22 ANELLO ALB/S	CIRCLIP D.22 - COUNTERSHAFT
16	F40899	1	ALBERO SECONDARIO 250N	SECONDARY SHAFT
17	F19524	1	GABBIA A RULLI 22X26X10 TAGL.	NEEDLE BEARING 22 X 26 X 10
18	F40901	1	INGR.2a VEL. Z28 A.S. 250N	GEAR 2 28T COUNTERSHAFT 250N
19	F40905	1	INGR.6a VEL. Z19 A.S. 250N	GEAR 6TH 19T, SECONDARY
20	F40902	1	INGR.3a VEL. Z29 A.S. 250N	GEAR 3 29T COUNTERSHAFT 250N
21	F40903	1	INGR.4a VEL. Z27 A.S. 250N	GEAR 4 27T COUNTERSHAFT 250N
22	F40904	1	INGR.5a VEL. Z25 A.S. 250N	GEAR 5th 25T COUNTERSHAFT 250N
23	F48353	1	SPESSORE PS 18X25X1	SPACER
24	F40900	1	INGR.1a VEL. Z30 A.S. 250N	GEAR, 1ST (30T) COUNTERSHAFT
25	F19514	1	GABBIA A RULLI 18X22X10	NEEDLE CAGE 18X22X10
26	48012	1	RASAMENTO A/S M/M SPESS.0,5	SPACER, 26x17x0,5





**4T250FIMX21-M**  
**MOTORE - ENGINE**

**CAMBIO 6 MARCE**  
**6 GEARS GEARBOX**

**10**

27	F03367	1	CUSCINETTO 6003 TN9C3 17x35x10	BUSH, 6003 TN9 C3 17x35x10
28	49603	1	RONDELLA M 6,4 X 12 X 1,6	WASHER 6x12
29	49480	1	VITE TCEI 6X10 UNI 5931	BOLT TCEI 6X10
30	F40888	1	ALBERO SEC.250Fi 6 MARCE CPL	SECONDARY SHAFT ASSY 6 GEARS
31	F40887	1	ALBERO PRIM.250Fi 6 MARCE CPL	PRIMARY SHAFT ASSY 6 GEARS

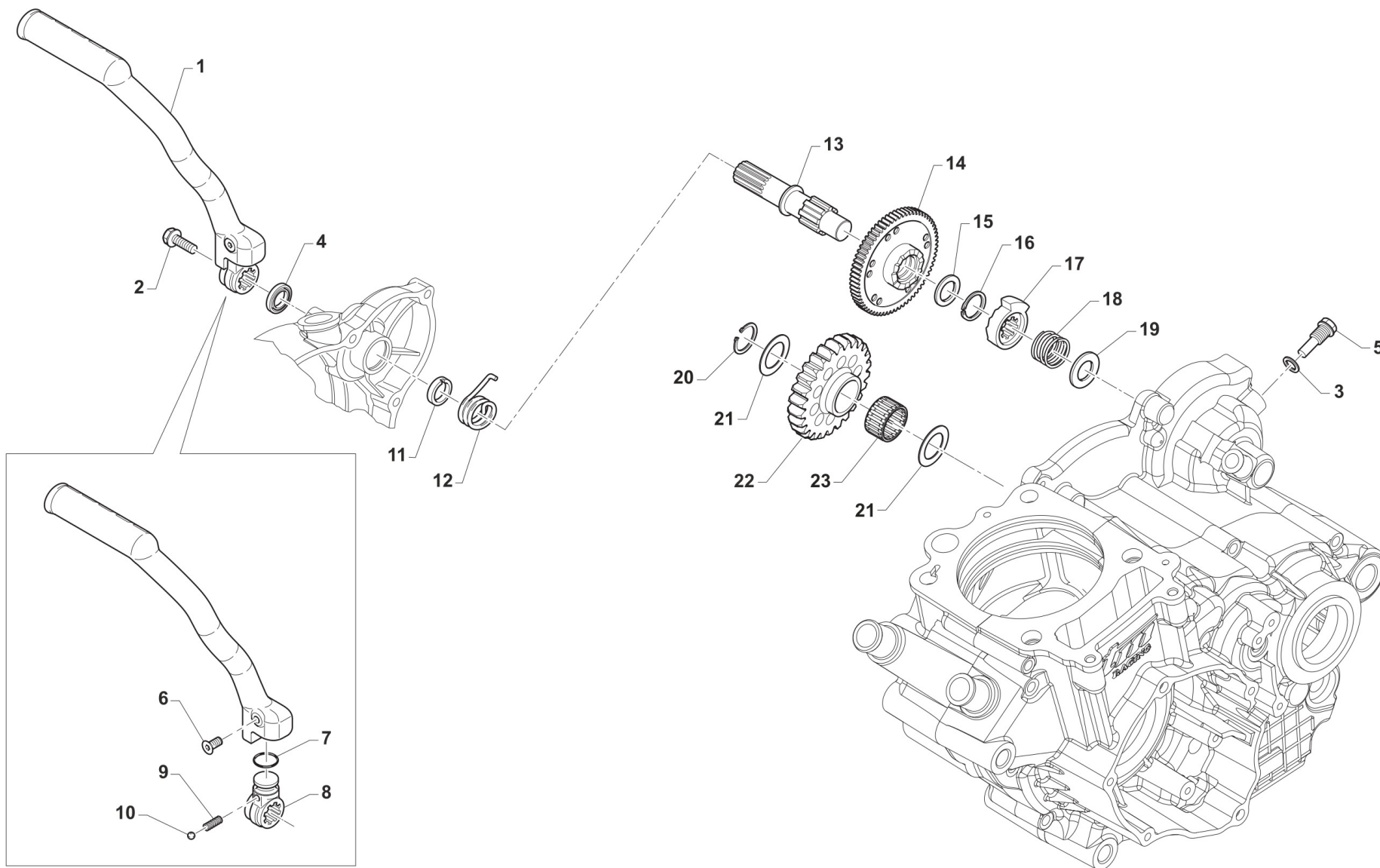

TM0010



**4T250FIMX21-M**  
**MOTORE - ENGINE**

**AVVIAMENTO PEDALE**  
**KICK STARTER**

1	F43369	1	LEVA M/M 250 Fi M. 10/->	LEVER, K/STARTER 250Fi 10/->
2	49369	1	VITE TE F/R 8X10 Ch.10 M/M	BOLT 8X10 T.10mm(Kich Starter)
3	F49939	1	RONDELLA RAME 8 X13 X 1,5	WASHER COPPER 8,5X13X1,5
4	F04365	1	PARAOLIO LEVA M/M 250/09	OIL SEAL 18x28x6,5 KS LEVER
5	F49825	1	VITE DISIMP.CRICCH.M/M.250Fi	BOLT
6	49414	1	VITE TSPEI 6X30 NORMALE UNI 5933	BOLT TSEI 6X30
7	12260	1	O RING INTERNO LEVA M/M 250	O-RING INT.LEVER KICK START250
8	F43368	1	MOZZETTO KICK START 250N 08	BLOCK, KICK STARTER 250N 08->
9	16039	1	MOLLA X SFERA LEVA M/M 250 CC	SPRING, BALL KICK-START. 250cc
10	43250.03	1	SFERA 1/4C X LEVA M/M 250 CC	BALL, KICK STARTER LEVER 250cc
11	F26423	1	BOCCOLA MOLLA M/M. 250Fi	BUSH
12	F16428	1	MOLLA RICHIAMO AVVIAMENTO A P.	SPRING, KICK STARTER RETURN 4S
13	F28657	1	ALBERO M/M 250Fi	SHAFT, KICK STARTER
14	F40908	1	INGR. COMANDO AVV.PEDALE 250N	GEAR, KICK START
15	F48355	1	SPESSORE TT 18 X 23 X 0,5	SHIM 18 X 23 X 0,5
16	F49835	1	SEEGER AV 18	SEEGER
17	F26424	1	BUSSOLA A CRICC.X K.S. 250N	K.STARTER STOPPER CAM 250 4S
18	F16429	1	MOLLA CRICCHETTO AVV.A PEDALE	SPRING
19	F48354	1	SPESSORE TT 14 X 30 X 0,5	SPACER
20	49253	1	SEEGER E17 INGR.FOLLE M/M 250	CIRCLIP, INTERMED.GEAR K.S.250
21	48012	2	RASAMENTO A/S M/M SPESS.0,5	SPACER, 26x17x0,5
22	F40892	1	INGRANAGGIO FOLLE K.S. 250F 08	GEAR, KICK START
23	19011	1	GABBIA A RULLI K 17X21X10	BUSH CAGE 17 X 21 X 10

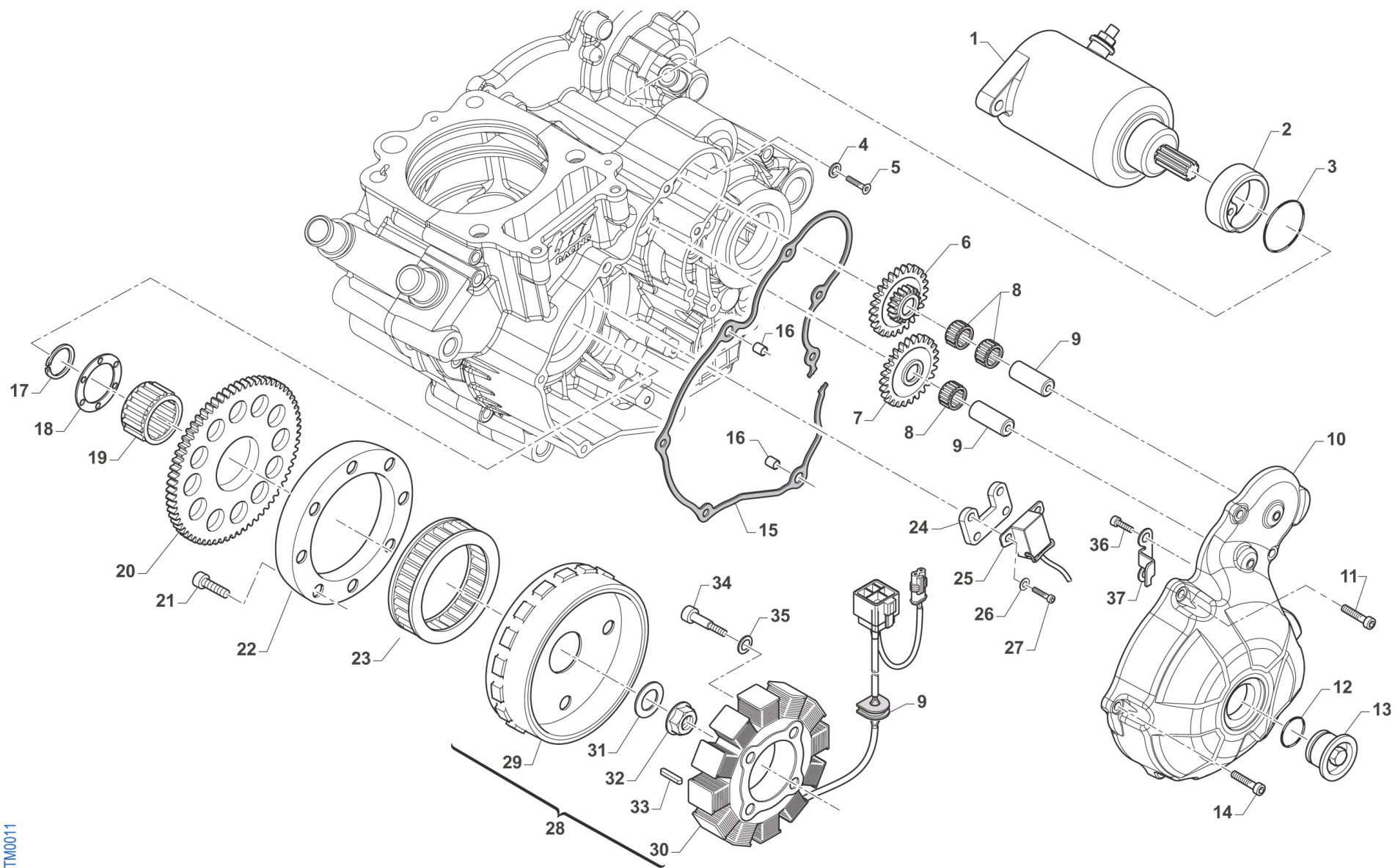

TM0011



**4T250FIMX21-M**  
**MOTORE - ENGINE**

**ACCENSIONE ES**  
**IGNITION ES**

**12**

1	F68145	1	MOTORINO AVVIAMENTO 250N M08 SM 14 A8323-048-00-000	E-STARTER ENGINE 250 4 S 08->
2	F26341	1	BOCCOLA CENTRAGGIO MOT.AVVIAM.	COLLAR, EL. STARTER
3	F12309	1	O RING 2150	O-RING, 2150
4	F49818	1	ROSETTA SPECIALE D.6 SVASATA	WASHER SPECIAL D.6
5	49399	1	VITE TSEI 5X12	BOLT TSEI 5x12
6	F40839	1	INGRANAGGIO DOPPIO RINF. E.S.	GEAR, ELECT. START
7	F40808	1	INGR. FOLLE AVVIAMENTO EL.	INTERMEDIATE GEAR
8	F19501	3	GABBIA A RULLI 10X13X10 4T	NEEDLE CAGE 10X13X10 F.S.
9	F28568	2	ALBERINO LUNGO ING. AVV.ELETTR	SHAFT, EL. STARTER GEAR
10	F30963	1	COP. ACC. 250Fi MX/ES 10/-> ATTACCO ACCENSIONE 4 FORI	COVER IGNITION 250Fi MX/ES10->
11	49477	2	VITE TCEI 5X25 UNI 5931	BOLT TCEI 5X25
12	F12322	1	O RING 2106	O-RING
13	F49833	1	TAPPO COPERCHIO ACC.250Fi	COVER CAP ALUMINIUM 250Fi
14	49476	5	VITE TCEI 5X20 UNI 5931	BOLT TCEI 5X20
15	F05829	1	GUARNIZ.COP.ACCENSIONE ES 250N	GASKET, INGNIT.COVER ES 250Fi
16	26041	2	GRANO CENTRAGGIO D.7X8 F.5,2	DOWEL PIN 7 x 8 Hole 5,2
17	F49937	1	SEEGER ALBERO E 36 4T	CIRCLIP 36 CRANKSH. E 4S
18	F26327	1	RONDELLA ACC. 37X53X2 4T	WASHER 37X50X2 4S.
19	F19506	1	GABBIA A RULLI AVV.EL.37X42X17	NEEDLE CAGE 37X42X17 E.S.
20	F40807	1	INGR. CONDOTTO AVVIAMENTO EL.	GEAR EL. STARTER
21	F49929	8	VITE TCE BASSA 6X16 (CL. 12.9)	SCREW TCE 6 X 16
22	F26385	1	ANELLO ESTERNO PESANTE R.L.KOK	EXTERNAL RING IGNITION KOKUSAN
23	F03354	1	RUOTA LIBERA MOTORINO AVV. 4T	FREE-WHEEL ELECTRIC STARTER
24	F08075	1	PIASTRINO PICK-UP 250Fi MX/ES	
25	F15478	1	PICK-UP KOKUSAN	PICK-UP KOK PU5157
26	49601	2	RONDELLA 5X11	WASHER 5x11
27	49452	2	VITE TE 8X30	



**4T250FIMX21-M**  
**MOTORE - ENGINE**

**ACCENSIONE ES**  
**IGNITION ES**

**12**

28	F15561	1	GENERATORE KOKUSAN MX E.S. KOK / SUMIT. 2V	GENERATOR KOKUSAN MX E.S.
29	F15549	1	ROTORE KOKUSAN YF9019	ROTOR, KOKUSAN YF9019
30	F15547	1	STATORE KOKUSAN YS 9018 C. KOK / SUM	
31	49613	1	RONDELLA ACCIAIO 12	STEEL WASHER 12
32	49056	1	DADO ACCENS 100/TAG/KZ 125MX/E	NUT, IGNITION 100cc
33	F49853	1	CHIAVETTA 5X3X25 UNI7510R.F.A.	WOODRUFF KEY, 5x3x25
34	49384	4	VITE TCEI 4X35	
35	49866	4	RONDELLA 4 x 12 x 1	
36	49553	2	VITE TCEI 4X8	BOLT TCEI 4X8
37	F30945	1	PROTEZIONE CAVI ACC.NE 250N	PROTECTION IGNITION WIRES 250N

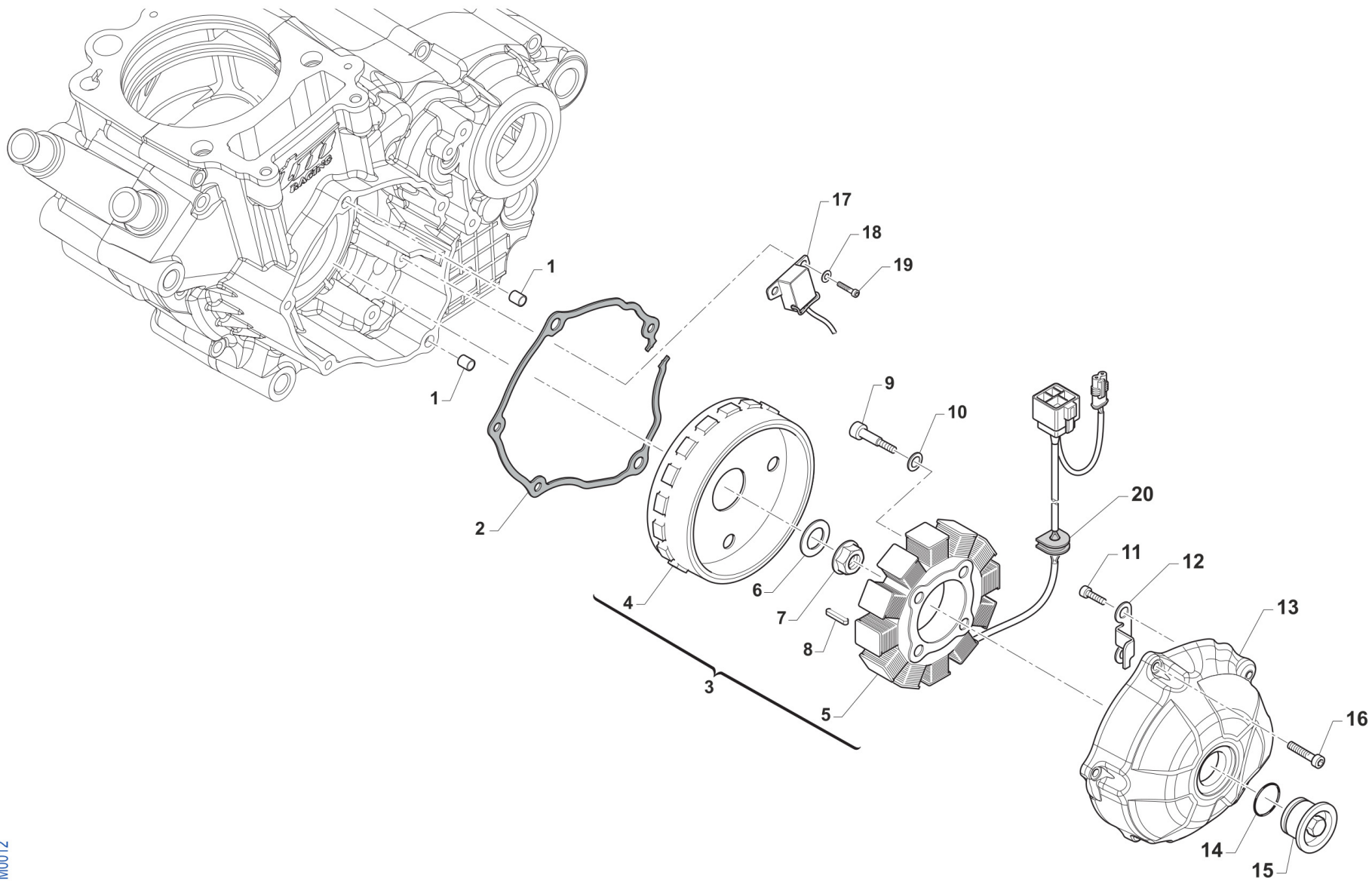

TM0012



**4T250FIMX21-M**  
**MOTORE - ENGINE**

**ACCENSIONE KS**  
**IGNITION KS**

**13**

1	26041	2	GRANO CENTRAGGIO D.7X8 F.5,2	DOWEL PIN 7 x 8 Hole 5,2
2	F05832	1	GUARNIZ.COP.ACCENSIONE KS 250N	GASKET, ING COVER KS 250Fi
3	F15560	1	GENERATORE KOKUSAN D.88 K.S. KOK / SUM	ACG KOK D.88 KS GP9018 CPL
4	F15548	1	ROTORE KOKUSAN YF9018	ROTOR KOKUSAN YF9018
5	F15547	1	STATORE KOKUSAN YS 9018 C. KOK / SUM	
6	49613	1	RONDELLA ACCIAIO 12	STEEL WASHER 12
7	49056	1	DADO ACCENS 100/TAG/KZ 125MX/E	NUT, IGNITION 100cc
8	F49853	1	CHIAVETTA 5X3X25 UNI7510R.F.A.	WOODRUFF KEY, 5x3x25
9	49384	4	VITE TCEI 4X35	
10	49866	4	RONDELLA 4 x 12 x 1	
11	49553	2	VITE TCEI 4X8	BOLT TCEI 4X8
12	F30945	1	PROTEZIONE CAVI ACC.NE 250N	PROTECTION IGNITION WIRES 250N
13	F30964	1	COP. ACCENSIONE 250Fi MX 11	COVER, IGN. 250Fi KS M. 11/->
14	F12322	1	O RING 2106	O-RING
15	F49833	1	TAPPO COPERCHIO ACC.250Fi	COVER CAP ALUMINIUM 250Fi
16	49476	5	VITE TCEI 5X20 UNI 5931	BOLT TCEI 5X20
17	F15478	1	PICK-UP KOKUSAN	PICK-UP KOK PU5157
18	49601	2	RONDELLA 5X11	WASHER 5x11
19	49474	2	VITE TCEI 5X16 UNI 5931	BOLT TCEI 5X16





## 4T250FIMX21-M MOTORE - ENGINE

-

03012	4T250FIMX18-M-08	17	1
03026	4T250FIMX18-M-03	8	2
03254	4T250FIMX18-M-09	1	1
	4T250FIMX18-M-10	1	1
04004	4T250FIMX18-M-08	26	1
04017	4T250FIMX18-M-05	9	1
04113	4T250FIMX18-M-09	13	1
	4T250FIMX18-M-10	13	1
09006	4T250FIMX18-M-07	9	1
12094	4T250FIMX18-M-05	30	1
12252	4T250FIMX18-M-07	33	1
12259	4T250FIMX18-M-07	35	2
12260	4T250FIMX18-M-11	7	1
16010	4T250FIMX18-M-08	6	1
16012	4T250FIMX18-M-08	13	2
16039	4T250FIMX18-M-11	9	1
19011	4T250FIMX18-M-11	23	1

19022	4T250FIMX18-M-07	10	1
19023	4T250FIMX18-M-07	11	1
19041	4T250FIMX18-M-08	31	1
19058	4T-ADLER250	16	1
19059	4T-ADLER250	17	1
21005	4T250FIMX18-M-07	24	8
26006	4T250FIMX18-M-08	7	1
26007	4T250FIMX18-M-08	23	1
26021	4T250FIMX18-M-08	15	1
26041	4T250FIMX18-M-05	15	2
	4T250FIMX18-M-12	16	2
	4T250FIMX18-M-13	1	2
26050	4T250FIMX18-M-08	4	1
26060	4T250FIMX18-M-08	10	1
26061	4T250FIMX18-M-08	11	1
26062	4T250FIMX18-M-08	12	2
26211	4T250FIMX18-M-07	40	2
28100	4T250FIMX18-M-08	3	1

33255	4T250FIMX18-M-08	29	1
33256	4T250FIMX18-M-08	18	1
35050	4T250FIMX18-M-07	17	1
35262	4T250FIMX18-M-07	21	1
35264	4T250FIMX18-M-07	32	1
35297	4T-ADLER250	8	7
40310	4T250FIMX18-M-08	14	1
43048	4T250FIMX18-M-08	27	1
43250.03	4T250FIMX18-M-11	10	1
48012	4T250FIMX18-M-09	26	1
	4T250FIMX18-M-10	26	1
	4T250FIMX18-M-11	21	2
48250	4T-ADLER250	15	1
	4T250FIMX18-M-07	28	2
48253	4T250FIMX18-M-09	2	1
	4T250FIMX18-M-10	2	1
49056	4T250FIMX18-M-12	32	1
	4T250FIMX18-M-13	7	1



**4T250FIMX21-M**  
**MOTORE - ENGINE**

-

49060	4T250FIMX18-M-07	16	1
49119	4T250FIMX18-M-05	13	1
49125	4T250FIMX18-M-06	4	2
49202	4T250FIMX18-M-07	22	8
49212	4T250FIMX18-M-08	28	1
49217	4T250FIMX18-M-09	15	1
	4T250FIMX18-M-10	15	1
49253	4T250FIMX18-M-11	20	1
49255	4T250FIMX18-M-03	13	1
49267	4T250FIMX18-M-05	42	1
49369	4T250FIMX18-M-11	2	1
49384	4T250FIMX18-M-12	34	4
	4T250FIMX18-M-13	9	4
49396	4T250FIMX21-M-02	30	1
49399	4T250FIMX18-M-12	5	1
49405	4T250FIMX18-M-08	8	2
49406	4T250FIMX18-M-04	26	1

49414	4T250FIMX18-M-11	6	1
49429	4T250FIMX18-M-05	47	1
49452	4T250FIMX18-M-12	27	2
49472	4T250FIMX18-M-03	11	1
49474	4T250FIMX18-M-13	19	2
49476	4T250FIMX18-M-05	3	3
	4T250FIMX18-M-12	14	5
	4T250FIMX18-M-13	16	5
49477	4T250FIMX18-M-05	14	7
	4T250FIMX18-M-07	2	4
	4T250FIMX18-M-12	11	2
49478	4T250FIMX18-M-05	20	1
49480	4T250FIMX18-M-09	29	1
	4T250FIMX18-M-10	29	1
49481	4T250FIMX21-M-02	33	3
49482	4T250FIMX21-M-02	2	4
49483	4T250FIMX18-M-08	16	2

49484	4T250FIMX18-M-07	5	6
49485	4T250FIMX18-M-08	25	1
49487	4T250FIMX18-M-04	1	8
	4T250FIMX18-M-06	11	4
49491	4T250FIMX18-M-06	10	3
49492	4T250FIMX18-M-06	12	1
49535	4T250FIMX18-M-07	30	2
49542	4T250FIMX18-M-06	7	1
49553	4T250FIMX18-M-12	36	2
	4T250FIMX18-M-13	11	2
	4T250FIMX21-M-02	27	2
49570	4T250FIMX18-M-05	2	1
49575	4T250FIMX18-M-05	1	1
49597	4T250FIMX18-M-04	13	1
49600	4T250FIMX18-M-05	41	1
49601	4T250FIMX18-M-12	26	2
	4T250FIMX18-M-13	18	2



**4T250FIMX21-M**  
**MOTORE - ENGINE**

-

49603	4T250FIMX18-M-08	2	1
	4T250FIMX18-M-09	28	1
	4T250FIMX18-M-10	28	1
49604	4T250FIMX18-M-07	6	6
	4T250FIMX18-M-08	24	1
49613	4T250FIMX18-M-12	31	1
	4T250FIMX18-M-13	6	1
49638	4T250FIMX18-M-08	1	1
49676	4T250FIMX18-M-01	12	2
49702	4T250FIMX21-M-02	5	1
49736	4T250FIMX18-M-07	1	2
49751	4T250FIMX18-M-05	37	2
49866	4T250FIMX18-M-12	35	4
	4T250FIMX18-M-13	10	4
49922	4T250FIMX18-M-06	14	2
49926	4T250FIMX18-M-06	15	2
49949	4T250FIMX18-M-04	29	1

49989	4T250FIMX21-M-02	39	3
F01727	4T250FIMX18-M-01	7	1
F02887	4T250FIMX18-M-04	2	1
F03354	4T250FIMX18-M-12	23	1
F03365	4T250FIMX18-M-05	27	1
F03367	4T250FIMX18-M-09	27	1
	4T250FIMX18-M-10	27	1
F03368	4T250FIMX18-M-09	10	2
	4T250FIMX18-M-10	10	2
F03375.4	4T250FIMX18-M-03	4	1
F03375.5	4T250FIMX18-M-03	4	1
F04363	4T250FIMX18-M-05	28	1
F04365	4T250FIMX18-M-11	4	1
F04366	4T250FIMX18-M-06	3	1
F04367	4T250FIMX18-M-07	38	1
F04375	4T250FIMX18-M-03	9	1
F04378	4T250FIMX21-M-02	11	4

F04388	4T250FIMX21-M-02	41	4
F04389	4T250FIMX18-M-06	17	1
F04390	4T250FIMX18-M-05	18	1
F05828	4T250FIMX18-M-05	16	1
F05829	4T250FIMX18-M-12	15	1
F05832	4T250FIMX18-M-13	2	1
F05833	4T250FIMX18-M-05	7	1
F05841	4T250FIMX18-M-07	4	1
F05856.1	4T250FIMX18-M-01	8	1
F05856.2	4T250FIMX18-M-01	8	1
F05856.3	4T250FIMX18-M-01	8	1
F05856.4	4T250FIMX18-M-01	8	1
F05862.1	4T250FIMX18-M-01	5	1
F05863	4T250FIMX18-M-06	16	1
F06116	4T250FIMX21-M-02	37	1
F08003	4T250FIMX21-M-02	40	1
F08075	4T250FIMX18-M-12	24	1



**4T250FIMX21-M**  
**MOTORE - ENGINE**

-

F08236.1	4T250FIMX18-M-06	13	1
F09385	4T250FIMX18-M-01	4	2
F09396.2	4T250FIMX18-M-01	3	1
F10863.95	4T250FIMX18-M-01	1	1
F10863.96	4T250FIMX18-M-01	1	1
F10863.97	4T250FIMX18-M-01	1	1
F10863.98	4T250FIMX18-M-01	1	1
F11384	4T250FIMX18-M-01	2	1
F12302	4T250FIMX18-M-05	31	1
	4T250FIMX18-M-07	44	1
F12309	4T250FIMX18-M-12	3	1
F12320	4T250FIMX18-M-09	11	1
	4T250FIMX18-M-10	11	1
F12322	4T250FIMX18-M-12	12	1
	4T250FIMX18-M-13	14	1
F12325	4T250FIMX18-M-05	21	1
	4T250FIMX21-M-02	19	2

F12327	4T250FIMX18-M-05	5	1
F12343	4T250FIMX18-M-05	23	1
F12344.1	4T250FIMX18-M-04	3	1
F12345.1	4T250FIMX21-M-02	4	1
F12346.1	4T250FIMX18-M-04	27	1
	4T250FIMX21-M-02	25	1
F12351.1	4T250FIMX21-M-02	31	1
F12356.1	4T250FIMX18-M-04	31	1
F12364	4T250FIMX21-M-02	3	1
F12380.1	4T250FIMX18-M-01	11	2
F13287	4T250FIMX21-M-02	38	1
F14158	4T250FIMX21-M-02	14	2
F14164	4T250FIMX21-M-02	15	2
F14178	4T250FIMX21-M-02	7	8
F15478	4T250FIMX18-M-12	25	1
	4T250FIMX18-M-13	17	1
F15547	4T250FIMX18-M-12	30	1

	4T250FIMX18-M-13	5	1
F15548	4T250FIMX18-M-13	4	1
F15549	4T250FIMX18-M-12	29	1
F15560	4T250FIMX18-M-13	3	1
F15561	4T250FIMX18-M-12	28	1
F16428	4T250FIMX18-M-11	12	1
F16429	4T250FIMX18-M-11	18	1
F16441	4T250FIMX18-M-05	40	1
F16445	4T250FIMX18-M-07	34	1
F16447	4T250FIMX18-M-08	22	1
F16453	4T250FIMX18-M-07	7	6
F16466	4T250FIMX18-M-04	15	1
F16472	4T250FIMX21-M-02	10	2
F16473	4T250FIMX21-M-02	9	2
F16479	4T250FIMX18-M-04	15	1
F18059	4T250FIMX18-M-03	5	1
F18093	4T250FIMX18-M-03	6	1



**4T250FIMX21-M**  
**MOTORE - ENGINE**

-

F18109	4T250FIMX18-M-03	1	1
F18110	4T250FIMX18-M-03	1	1
F18111	4T250FIMX18-M-03	3	1
F18121	4T250FIMX18-M-03	2	1
F18122	4T250FIMX18-M-03	2	1
F19501	4T250FIMX18-M-12	8	3
F19506	4T250FIMX18-M-12	19	1
F19510	4T250FIMX18-M-07	26	1
F19511	4T250FIMX18-M-05	52	1
F19512	4T250FIMX18-M-05	49	2
F19513	4T250FIMX18-M-05	35	3
F19514	4T250FIMX18-M-09	25	1
	4T250FIMX18-M-10	25	1
F19518	4T250FIMX18-M-07	37	1
F19521	4T250FIMX18-M-05	45	2
F19524	4T250FIMX18-M-09	17	1
	4T250FIMX18-M-10	17	1

F19526	4T250FIMX18-M-04	21	1
F19529	4T250FIMX18-M-04	4	4
F19530	4T250FIMX18-M-04	11	1
F20003	4T250FIMX18-M-06	9	1
F20004	4T250FIMX18-M-06	8	1
F21436	4T250FIMX21-M-02	36	1
F25256	4T250FIMX18-M-07	18	1
F25257	4T250FIMX18-M-07	23	1
F25258	4T250FIMX18-M-07	8	1
F26327	4T250FIMX18-M-12	18	1
F26341	4T250FIMX18-M-12	2	1
F26385	4T250FIMX18-M-12	22	1
F26421	4T250FIMX18-M-09	12	1
	4T250FIMX18-M-10	12	1
F26422	4T250FIMX18-M-07	27	1
F26423	4T250FIMX18-M-11	11	1
F26424	4T250FIMX18-M-11	17	1

F26428	4T250FIMX18-M-01	6	2
	4T250FIMX18-M-06	6	4
F26454	4T250FIMX18-M-08	9	1
F26455	4T250FIMX18-M-08	5	1
F26460	4T250FIMX18-M-07	43	1
F26474	4T250FIMX21-M-02	13	4
F26479	4T250FIMX18-M-08	21	1
F26491	4T250FIMX18-M-09	4	1
F26557	4T250FIMX21-M-02	16	2
F26558	4T250FIMX21-M-02	17	2
F26575	4T250FIMX18-M-04	12	1
F26576	4T250FIMX18-M-04	16	1
F26597	4T250FIMX21-M-02	8	4
F26603.255	4T250FIMX21-M-02	6	1
F26603.260	4T250FIMX21-M-02	6	1
F26603.265	4T250FIMX21-M-02	6	1
F26603.270	4T250FIMX21-M-02	6	1



**4T250FIMX21-M**  
**MOTORE - ENGINE**

-

F26603.275	4T250FIMX21-M-02	6	1
F26603.280	4T250FIMX21-M-02	6	1
F26603.285	4T250FIMX21-M-02	6	1
F26603.290	4T250FIMX21-M-02	6	1
F26603.295	4T250FIMX21-M-02	6	1
F26603.300	4T250FIMX21-M-02	6	1
F26603.305	4T250FIMX21-M-02	6	1
F26603.310	4T250FIMX21-M-02	6	1
F26603.315	4T250FIMX21-M-02	6	1
F26603.320	4T250FIMX21-M-02	6	1
F26603.325	4T250FIMX21-M-02	6	1
F26603.330	4T250FIMX21-M-02	6	1
F26689	4T250FIMX21-M-02	12	4
F26728	4T250FIMX21-M-02	42	4
F28568	4T250FIMX18-M-12	9	2
F28657	4T250FIMX18-M-11	13	1
F28658	4T250FIMX18-M-05	25	1

F28665	4T250FIMX18-M-05	51	1
F28679	4T250FIMX18-M-05	8	1
F28807	4T250FIMX18-M-04	9	1
F28809	4T250FIMX18-M-04	10	1
F28810	4T250FIMX21-M-02	28	1
F28811	4T250FIMX21-M-02	21	1
F28812	4T250FIMX21-M-02	20	1
F28813	4T250FIMX18-M-04	22	1
F28835	4T250FIMX21-M-02	23	3
F28836	4T250FIMX21-M-02	22	1
F28840	4T250FIMX18-M-05	36	1
F28841	4T250FIMX21-M-02	24	1
F28845	4T250FIMX18-M-04	6	1
F28846	4T250FIMX18-M-04	7	1
F28852	4T250FIMX18-M-04	6	1
F30005	4T250FIMX18-M-07	29	1
F30006	4T250FIMX18-M-07	31	1

F30015	4T250FIMX21-M-02	32	1
F30059	4T250FIMX18-M-05	38	1
F30060	4T250FIMX18-M-04	5	2
F30061	4T250FIMX21-M-02	1	1
F30068	4T250FIMX18-M-05	33	1
F30069	4T250FIMX18-M-06	1	1
F30070	4T250FIMX18-M-06	1	1
F30944	4T250FIMX18-M-07	41	1
F30945	4T250FIMX18-M-12	37	1
	4T250FIMX18-M-13	12	1
F30960	4T250FIMX18-M-07	3	1
F30961	4T250FIMX18-M-05	12	1
F30963	4T250FIMX18-M-12	10	1
F30964	4T250FIMX18-M-13	13	1
F30965	4T250FIMX18-M-05	32	1
F30966	4T250FIMX18-M-05	4	1
F32529	4T250FIMX18-M-05	17	1



## 4T250FIMX21-M MOTORE - ENGINE

-

F32532	4T250FIMX18-M-05	22	1
F32533	4T250FIMX18-M-05	39	1
F32555	4T250FIMX18-M-05	24	1
F32573	4T250FIMX18-M-03	10	1
F32574	4T250FIMX18-M-05	46	1
F32577	4T250FIMX18-M-05	43	3
F32578	4T250FIMX18-M-05	44	3
F33311	4T250FIMX18-M-08	30	1
F33312	4T250FIMX18-M-08	19	2
F33329	4T250FIMX18-M-08	20	1
F33330	4T250FIMX18-M-08	20	1
F35522	4T250FIMX18-M-07	36	1
F35523	4T250FIMX18-M-07	39	1
F35537	4T-ADLER250	7	3
F35541	4T250FIMX18-M-07	15	5
F35544	4T250FIMX18-M-07	19	1
F35556	4T-ADLER250	10	1
F35561	4T-ADLER250	14	1
F35562	4T-ADLER250	13	1

F35564	4T-ADLER250	3	4
F35572	4T-ADLER250	1	1
F35573	4T-ADLER250	3	1
F35580	4T-ADLER250	18	1
F35582	4T250FIMX18-M-07	12	1
F35583	4T-ADLER250	5	3
F35584	4T-ADLER250	19	3
F35585	4T-ADLER250	6	3
F35586	4T-ADLER250	12	1
F35588	4T-ADLER250	9	7
	4T250FIMX18-M-07	13	8
F35596	4T250FIMX18-M-07	14	2
F40038	4T250FIMX18-M-07	20	1
F40057	4T250FIMX18-M-03	12	1
F40057.1	4T250FIMX18-M-03	12	1
F40057.3	4T250FIMX18-M-03	12	1
F40061	4T250FIMX18-M-04	20	1
F40062	4T250FIMX18-M-04	8	2
F40807	4T250FIMX18-M-12	20	1
F40808	4T250FIMX18-M-12	7	1
F40839	4T250FIMX18-M-12	6	1

F40887	4T250FIMX18-M-10	31	1
F40888	4T250FIMX18-M-10	30	1
F40889	4T250FIMX18-M-09	14	1
	4T250FIMX18-M-10	14	1
F40892	4T250FIMX18-M-11	22	1
F40893	4T250FIMX18-M-09	9	1
	4T250FIMX18-M-10	9	1
F40894	4T250FIMX18-M-09	3	1
	4T250FIMX18-M-10	3	1
F40895	4T250FIMX18-M-09	7	1
	4T250FIMX18-M-10	7	1
F40896	4T250FIMX18-M-09	5	5
	4T250FIMX18-M-10	5	5
F40897	4T250FIMX18-M-09	8	1
	4T250FIMX18-M-10	8	1
F40898	4T250FIMX18-M-10	4	1
F40899	4T250FIMX18-M-09	16	1



**4T250FIMX21-M**  
**MOTORE - ENGINE**

-

	4T250FIMX18-M-10	16	1
F40900	4T250FIMX18-M-09	24	1
	4T250FIMX18-M-10	24	1
F40901	4T250FIMX18-M-09	18	1
	4T250FIMX18-M-10	18	1
F40902	4T250FIMX18-M-09	20	1
	4T250FIMX18-M-10	20	1
F40903	4T250FIMX18-M-09	21	1
	4T250FIMX18-M-10	21	1
F40904	4T250FIMX18-M-09	22	1
	4T250FIMX18-M-10	22	1
F40905	4T250FIMX18-M-10	19	1
F40908	4T250FIMX18-M-11	14	1
F40909	4T250FIMX18-M-05	50	1
F40933	4T250FIMX18-M-09	14	1
	4T250FIMX18-M-10	14	1
F40949	4T250FIMX18-M-09	19	1

F40954	4T250FIMX18-M-07	25	1
F40955	4T250FIMX18-M-05	26	1
F40956	4T250FIMX18-M-09	14	1
	4T250FIMX18-M-10	14	1
F40967	4T250FIMX18-M-09	31	1
F40968	4T250FIMX18-M-09	30	1
F40997	4T250FIMX18-M-05	34	1
F43368	4T250FIMX18-M-11	8	1
F43369	4T250FIMX18-M-11	1	1
F48353	4T250FIMX18-M-09	23	1
	4T250FIMX18-M-10	23	1
F48354	4T250FIMX18-M-11	19	1
F48355	4T250FIMX18-M-11	15	1
F48368	4T250FIMX18-M-04	14	1
F48371	4T250FIMX21-M-02	29	1
F48372	4T250FIMX18-M-04	19	2
F48374	4T250FIMX21-M-02	26	2

F48400	4T250FIMX21-M-02	35	4
F49045	4T250FIMX18-M-01	10	4
F49818	4T250FIMX18-M-12	4	1
F49820.1	4T250FIMX18-M-06	5	2
F49821	4T250FIMX18-M-05	48	1
F49825	4T250FIMX18-M-11	5	1
F49832	4T250FIMX18-M-06	2	1
F49833	4T250FIMX18-M-12	13	1
	4T250FIMX18-M-13	15	1
F49835	4T250FIMX18-M-11	16	1
F49838	4T250FIMX18-M-09	6	5
	4T250FIMX18-M-10	6	5
F49841	4T250FIMX18-M-05	6	1
F49853	4T250FIMX18-M-03	7	1
	4T250FIMX18-M-12	33	1
	4T250FIMX18-M-13	8	1
F49871	4T250FIMX18-M-04	17	1





**4T250FIMX21-M**  
**MOTORE - ENGINE**

-

	4T250FIMX21-M-02	18	2
F49874	4T250FIMX21-M-02	34	4
F49875	4T250FIMX18-M-01	9	2
F49883	4T250FIMX18-M-04	25	2
F49884	4T250FIMX18-M-04	30	1
F49913	4T250FIMX18-M-05	19	1
F49920	4T250FIMX18-M-05	11	1
F49925	4T250FIMX18-M-05	10	1
F49929	4T250FIMX18-M-12	21	8
F49937	4T250FIMX18-M-12	17	1
F49939	4T250FIMX18-M-11	3	1
F66510	4T250FIMX18-M-05	29	1
F68145	4T250FIMX18-M-12	1	1
F70370	4T250FIMX18-M-07	42	1
F70404	4T250FIMX18-M-04	23	1
F70408	4T250FIMX18-M-04	28	1
F70413	4T250FIMX18-M-04	24	1

F70422	4T250FIMX18-M-04	18	1
ND	4T-ADLER250	20	1
	4T-ADLER250	21	1