



USES AND
RACOMMENDS



www.tmracing.it

TM Racing SpA - Via Fano, 6
61122 Pesaro - ITALY
Phone: +39 0721 25113

4T530FIMX21-M

MOTORE
ENGINE

28/02/2022



INFORMAZIONI GENERALI

Il presente catalogo serve per richiedere con esattezza le parti di ricambio.

Nelle ordinazioni indicare:

1) Il numero di matricola del Telaio che è stampigliato sul lato destro del canotto di sterzo. Nei modelli EN, SMR, SMR il numero di matricola è riportato anche su una targhetta posta sul lato sinistro (Vedi foto).

2) il numero di serie del Motore. E' posto sulla sinistra del motore tra la leva cambio e i coperchio accensione (Vedi foto).

3) Il codice dei particolari seguito dalla descrizione.

4) Il colore per i pezzi verniciati o comunque colorati.

Le indicazioni destra e sinistra si riferiscono ai lati del veicolo rispetto al senso di marcia.

Foto e disegni sono solo a scopo informativo e potrebbero non corrispondere esattamente alle caratteristiche dei prodotti.

GENERAL INFORMATION

The present spare parts catalogue enables one to order exactly the right spare part.

When ordering specify:

1) The frame serial number. It is embossed on the right side of the steering metal tube. In the EN, SMR and SMR models, the serial number is also stated on a plate positioned on the left hand side (See photo).

2) The engine serial numer. It is located on the left side of the engine between the gear lever and the ignition cover (See photo).

3) The part's code number followed but its description.

4) Indicate colour for painted or colored parts.

References to right and left apply to the vehicle in terms of its direction of movement.

Photos and drawings are for informational purposes only and may not exactly match the characteristics of the products.

NOTE – LEGENDA

MY

NOVITA' INTRODOTTA DIFFERENTE O NON PRESENTE NEL MODELLO DELL'ANNO PRECEDENTE

PART DIFFERENT OR NOT PRESENT IN THE REVIOUS YEAR MODEL

5M

MOTORE CON CAMBIO A 5 MARCE
ENGINE WITH 5 GEARS SPEED

6M

MOTORE CON CAMBIO A 6 MARCE
ENGINE WITH 6 GEARS SPEED

KS

MOTORE CON SOLO KICK STARTER
ENGINE WITH KICK STARTER ONLY

ES

MOTORE CON AVVIAMENTO ELETTRICO
ENGINE WITH ELECTRIC STARTER

X

RICAMBIO NON DISPONIBILE ALLA VENDITA
PART CAN NOT BE SOLD SEPARATELY



Le illustrazioni riportate in questo manuale sono fornite solo come riferimento e possono variare dal prodotto effettivo,

Dati indicativi soggetti a modifiche senza impegno di preavviso.

The illustrations in this manual are for reference only and may vary from the actual product.

All data are subject to modification without prior notice.



4T530FIMX21-M
MOTORE - ENGINE

BASAMENTO E CILINDRO.....	4
TESTA - HEAD.....	7
DISTRIBUZIONE - VALVES COVER.....	10
ALBERO MOTORE E PISTONE - CRANKSHAFT AND PISTON.....	13
LUBRIFICAZIONE - LUBRIFICATION.....	15
FRIZIONE - CLUTCH.....	18
COMANDO CAMBIO - GEARSHIFT MECHANISM.....	21
CAMBIO - GEAR BOX.....	24
MESSA IN MOTO - KICK STARTER.....	27
ACCENSIONE ES - IGNITION ES.....	29
ACCENSIONE KS - IGNITION KS.....	32
-	34

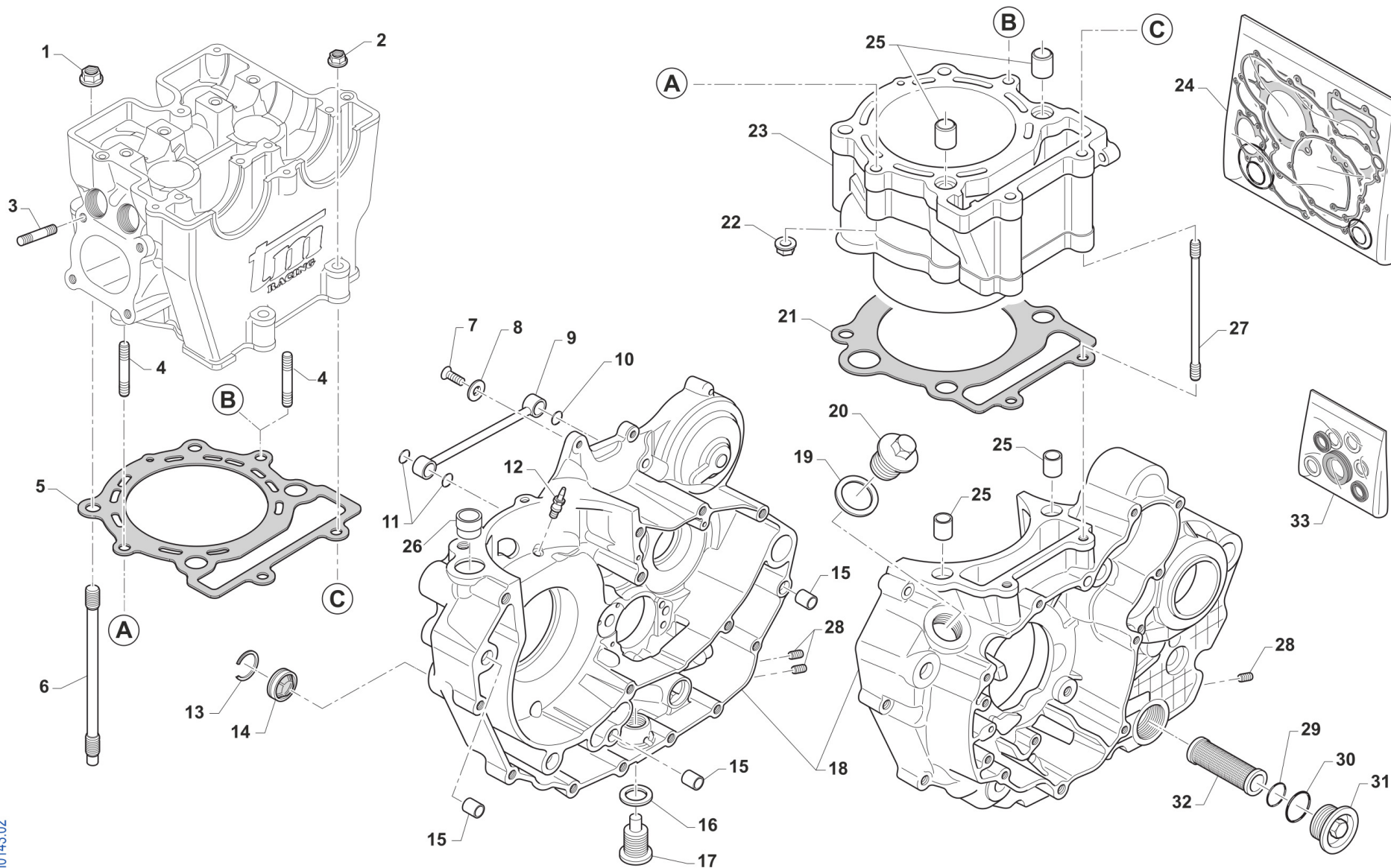

TM0143.02



4T530FIMX21-M
MOTORE - ENGINE

BASAMENTO E CILINDRO

1

1	49681	4	DADO M 10 X 1,25 CH 14 FLANG. AUTOBLOCK	NUT M10x1,25 FLANGED SELF-LOCK
2	49676	2	DADO M 6X1 FLANG. AUTOBL.ACC.	NUT, FLANGED M6 X 1 S.B.
3	F49926	2	PRIGIONIERO M8 TESTA/CIL450/53	STUD M8 HEAD / CYLINDER 450cc
5	F05846	1	GUARN. TESTA/CIL.D.98 BIL.COM.	GASKET, CYL./HEAD D.98mm
6	F49982	4	PRIGIONIERO M10X1.25 L.201 ASP	STUD M10 X 1.25 X 201
7	49399	1	VITE TSEI 5X12	BOLT TSEI 5x12
8	49604	1	RONDELLA 6 X18 X 1,6	WASHER 6x18
9	F32506	1	CONDOTTO OLIO PER CAMBIO/CIL.	OIL HOSE FOR GEAR BOX/ CIL.
10	F12302	1	O RING 108 PIOGGIA CAMBIO 4T	O-RING, 108 GEAR F.S.
11	F12301	2	O RING 106 4T PIOGGIA CAMBIO	O-RING, 106 GEAR F.S.
12	F32515	1	UGELLO LUBRIFICAZIONE SPINOTTO	COOLING PISTON PIN, OIL JET
13	F49923	1	SEEGER OBLO' OLIO 450Fi SB 35	CIRCLIP BR 35
14	F04355	1	OBLO' LIVELLO OLIO DIAMETRO 35 X 6 mm	WINDOW, OIL LEVEL D. 35 MM
15	F26428	3	GRANO RIFERIMENTO 12X13 F10.2	GRUB SCREW 12X13 H.10,2mm
16	F49933	1	RONDELLA ALL 16X24X1,5 4T	WASHER 16X24X1,5 ALUM.
17	F49905.1	1	TAPPO OLIO C/CALAM. 4T	OIL PLUG WITH MAGNET 4S
18	F30077	1	BASAMENTO MOT. 530Fi ES MY15	
18	F30078	1	BASAMENTO MOT. 530Fi KS MY15	
19	F49920	1	RONDELLA ALL 20.4X26X1.5	WASHER 20,4X26X1,5 ALUM.
20	F49925	1	TAPPO CARICO OLIO M20X1.5	OIL PLUG M20X1,5
21	F05843.1	1	GUARN.CIL/BAS D.108.5 SP,0,3	GASKET, CYL D.108.5 0.30 mm
21	F05843.2	1	GUARN.CIL/BAS D.108.5 SP,0,4	GASKET, CYL D.108.5 0.40 mm
21	F05843.3	1	GUARN.CIL/BAS D.108.5 SP,0,5	GASKET, CYL D.108.5 0.50 mm
21	F05843.4	1	GUARN.CIL/BAS D.108.5 SP,0,6	GASKET, CYL D.108.5 0.60 mm
22	49640.85	2	DADO M 8 FLANG.CHIAVE 12x 85cc	NUT M8 FLANGED 12mm TOOL 85cc
23	F01705	1	CILINDRO 530 CC 4T INTEG.	CYLINDER 530cc 4 Str. Int.
24	F05830.530	1	KIT GUARN. + OR 4T 530Fi	
25	F26301	4	GRANO RIF. 14X9.5 F.12.2 4T	GRUB SCREW 14X9.5 F12.2 F.S.



4T530FIMX21-M
MOTORE - ENGINE

BASAMENTO E CILINDRO

1

26	F26403	1	TUBO DI COLLEGAMENTO MOD. 05	
27	F49922	2	PRIGIONIERO M 6 x 133,5 530	STUD M 6 CYL.HEAD/CRANKC.530cc
28	F49972	3	GRANO M10X12	
29	F12312	1	O RING FILTRO OLIO P.ASPIRAZ.+LEV.	O-RING, OIL FILTER
30	F12311	1	O RING TAPPO FILTRO OLIO P.AS.	O RING OIL FILTER CAP
31	F32512	1	TAPPO FILTRO ASPIRAZIONE OLIO	OIL FILTER PLUG
32	F32511	1	FILTRO ASP.POMPA MANDATA OLIO	FILTER, OIL PUMP
33	04036	1	KIT PARAOLIO 450/530	OIL SEAL KIT 450/530 cc

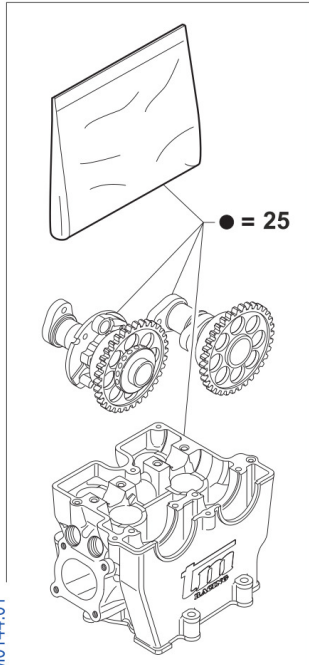
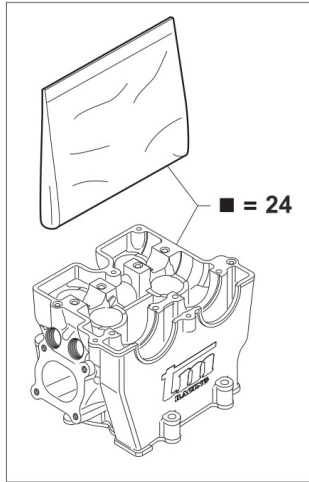

TM0144.01

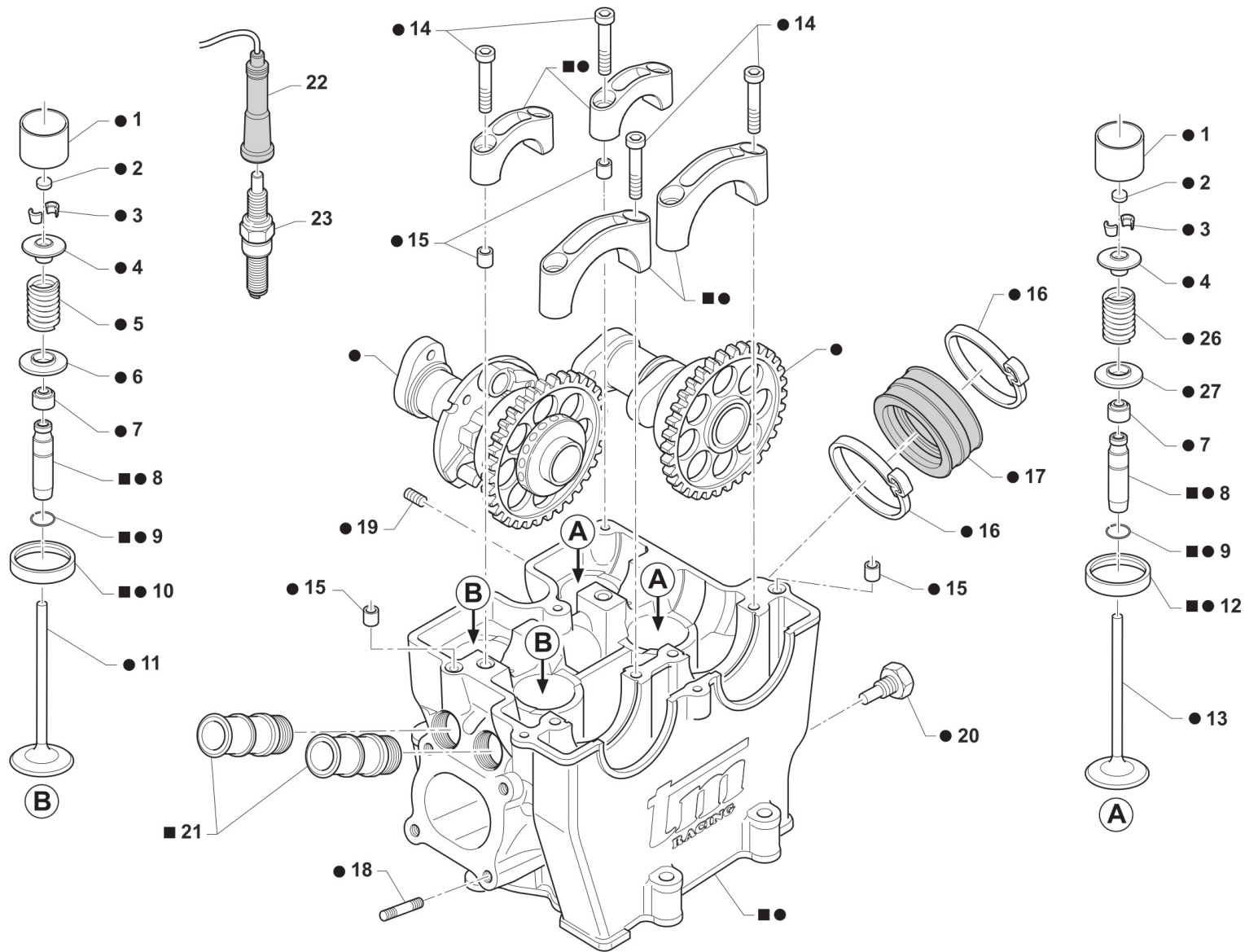



4T530FIMX21-M
MOTORE - ENGINE

TESTA
HEAD

1	F26361	4	BICCHIERINO D25 PIATTO K110	CAM BUCKET D.25 - K110
2	F26337.240	1	PASTIGLIA REGOLAZ.GIOCO 2,40	SHIM, VALVE ADJUSTING 2.40
2	F26337.245	1	PASTIGLIA REGOLAZ.GIOCO 2,45	SHIM, VALVE ADJUSTING 2.45
2	F26337.250	1	PASTIGLIA REGOLAZ.GIOCO 2,50	SHIM, VALVE ADJUSTING 2.50
2	F26337.255	1	PASTIGLIA REGOLAZ.GIOCO 2,55	SHIM, VALVE ADJUSTING 2.55
2	F26337.260	1	PASTIGLIA REGOLAZ.GIOCO 2,60	SHIM, VALVE ADJUSTING 2.60
2	F26337.265	1	PASTIGLIA REGOLAZ.GIOCO 2,65	SHIM, VALVE ADJUSTING 2.65
2	F26337.270	1	PASTIGLIA REGOLAZ.GIOCO 2,70	SHIM, VALVE ADJUSTING 2.70
2	F26337.275	1	PASTIGLIA REGOLAZ.GIOCO 2,75	SHIM, VALVE ADJUSTING 2.75
2	F26337.280	1	PASTIGLIA REGOLAZ.GIOCO 2,80	SHIM, VALVE ADJUSTING 2.80
2	F26337.285	1	PASTIGLIA REGOLAZ.GIOCO 2,85	SHIM, VALVE ADJUSTING 2.85
2	F26337.290	1	PASTIGLIA REGOLAZ.GIOCO 2,90	SHIM, VALVE ADJUSTING 2.90
2	F26337.295	1	PASTIGLIA REGOLAZ.GIOCO 2,95	SHIM, VALVE ADJUSTING 2.95
2	F26337.300	1	PASTIGLIA REGOLAZ.GIOCO 3,00	SHIM, VALVE ADJUSTING 3.00
2	F26337.305	1	PASTIGLIA REGOLAZ.GIOCO 3,05	SHIM, VALVE ADJUSTING 3.05
2	F26337.310	1	PASTIGLIA REGOLAZ.GIOCO 3,10	SHIM, VALVE ADJUSTING 3.10
2	F26337.315	1	PASTIGLIA REGOLAZ.GIOCO 3,15	SHIM, VALVE ADJUSTING 3.15
2	F26337.320	1	PASTIGLIA REGOLAZ.GIOCO 3,20	SHIM, VALVE ADJUSTING 3.20
2	F26337.325	1	PASTIGLIA REGOLAZ.GIOCO 3,25	SHIM, VALVE ADJUSTING 3.25
2	F26337.330	1	PASTIGLIA REGOLAZ.GIOCO 3,30	SHIM, VALVE ADJUSTING 3.30
2	F26337.335	1	PASTIGLIA REGOLAZ.GIOCO 3,35	SHIM, VALVE ADJUSTING 3.35
2	F26337.340	1	PASTIGLIA REGOLAZ.GIOCO 3,40	SHIM, VALVE ADJUSTING 3.40
2	F26337.345	1	PASTIGLIA REGOLAZ.GIOCO 3,45	SHIM, VALVE ADJUSTING 3.45
3	F14121	8	SEMICONO Diam. 5,5	VALVE COLLETS D.5,5
4	F26701	4	PIATTELLO SUPERIORE MOLLE F16472 / 73 450 4T	
5	F16473	2	SET MOLLA EST. + MOLLA INT. SCAR.	EXTER. & INTER.SPRINGS EXHAUST
6	F26706	2	PIATTELLO INFERIORE MOLLA F16473 450 MX	
7	F04356	4	PARAOLIO VALVOLA 4T VSS-305	VALVE-STEAM SEALING VS-3002



4T530FIMX21-M
MOTORE - ENGINE

TESTA
HEAD

2

8	F26565	4	GUIDA VALVOLA	VALVE GUIDE
9	F49910	4	SEEGER RW D.10 4T	CIRCLIP RW D.10 4S
10	F26560	2	SEDE VALV.SCAR.450cc Øe 33.5 Øi 26 SINT. (VALV. Ø 31)	
11	F14136	2	VALVOLA SCAR. D.31 X 5,5 TIT	VALVE, EXHAUST D.31 x 5,5 TIT
12	F26559	2	SEDE VALV.ASP.450cc Øe 39 Øi 31 SINT. (VALV. Ø 36)	
13	F14135	2	VALVOLA ASP. D.36 X 5,5 TIT	VALVE, INLET D.36 x 5,5 TIT
14	49487	8	VITE TCEI 6X35 UNI 5931	BOLT TCEI 6X35
15	F26304	6	GRANO RIFERIMENTO 6.5X8X9.5 4T	GRUB SCREW 6.5X8XX9.5 4S
16	F51101	2	FASCETTA SM9 D.56 CARBUR. 4T	CARBURETOR CLAMP D.56
17	F13255	1	COLLETTORE ASPIRAZION.GOMMA 4T	RUBBER INTAKE MANIFOLD F.S.
18	49151	4	PRIGIONIERO M6X27,4 CARB.100	STUD M 6x27
19	F49919	2	GRANO 6X 6 ESTREM.PIATTA 4T	GRUB, 6 X 6 4 Str.
20	F08003	1	SENSORE TEMP. ACQUA WTS 09/02	SENSOR, WATER TEMPERATURE
21	F28515	2	RACCORDO ACQUA TESTA 4T+125 2T	WATER JOINT, HEAD F.S.
22	F21401	1	PIPETTA CANDELA NGK SD05F 4T	CAP, SPARK PLUG NGK SD05F F.S.
23	F06105	1	CANDELA NGK CR9EIX CON/NIPPLO	SPARK PLUG NGK CR9EIX
24	F02860.1	1	TESTA 450Fi MX SEMI-CPL (860) 15/20SEDI SINT+GUIDE SINT+CAPP.	
25	F02860.4	1	TESTA 450Fi MX CPL (860) 19/20	
26	F16472	2	SET MOLLA EST. + MOLLA INT. ASP.	EXTER. & INTER.SPRINGS INLET
27	F26705	2	PIATTELLO INFERIORE MOLLA F16472 450 MX	

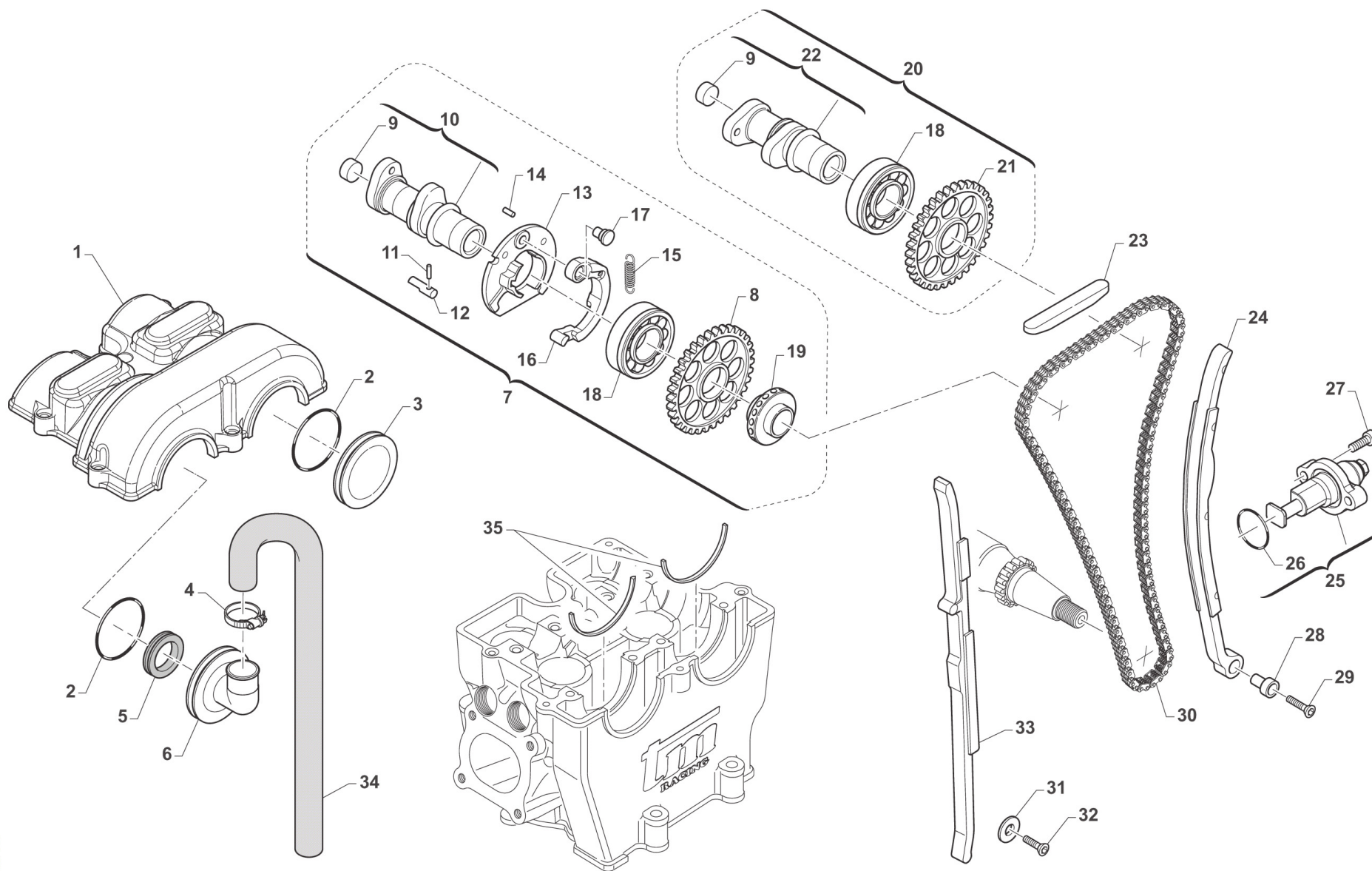

TM0141



4T530FIMX21-M
MOTORE - ENGINE

DISTRIBUZIONE
VALVES COVER

1	F30790	1	COPERCHIO TESTA 4T 04/09 450cc	CYLINDER HEAD COVER F.S.M.04->
2	F12307	2	O RING 3156 COPER.C.A.CAMMES 4T	O-RING, 3156 CAMMES COVER F.S.
3	F30832	1	COPERCHIETTO A CAMMES 04	
4	51073	1	FASCETTA 10/19	CLAMP 10 / 19 mm
5	F04361	1	PARAOLIO 20 30 05	OIL SEAL 20x30x5
6	F30868	1	COPERCHIETTO CAMME X SF.A CENT	
7	F28689.530	1	ALBERO A CAMME SCARICO 530 CPL S1	
8	F40883	1	RUOTA DENT.ALB.CAMME SCAR. X CATENA 92RH2015	GEAR, EXHAUST CAMSHAFT 4S
9	F26377	2	TAPPO ALBERO A CAMME 4T	
10	F28649	1	ALBERO A CAMME SCAR INT 38-S1	
11	F19505	1	RULLINO D.2,5 X 13,8	NEEDLE ROLLER 2,5 X 13,8
12	F26345	1	CAMMA ROTANTE	ROTARY CAM
13	F26343	1	FLANGIA DECOMPR. CENTRIFUGO	FLANGE CENTRIFUGAL DECOMPRES.
14	F19504	1	RULLO D.4 X 8	PIN D.4 X 8
15	F16410	1	MOLLA DECOMPR.AUTOMATICO CAMMA	SPRING, AUTOMATIC DECOMPR. CAM
16	F26344	1	LEVA DECOMPRESSORE CENTRIFUGO	LEVER, CENTRIFUGAL DECOMPR.
17	F26346	1	PERNO DA RIBATTERE	PIN FOR LEVER
18	F03353	2	CUSCINETTO ALBERI A CAMMES	BUSH 60/22 NC CAMSHAFT
19	F32523	1	CENTRIFUGATORE X SF.OLIO.CENTR	
20	F28688.530	1	ALB. CAMME ASPIRAZIONE 530 N1 CPL	
21	F40882	1	RUOTA DENT.ALB.CAMME ASP. X CATENA 92RH2015	GEAR, INLET CAMSHAFT 4S
22	F28598	1	ALBERO A CAMME ASP.INT 43 N1	
23	F70309	1	PATTINO SUP. CATENA DISTR. 4T	GUIDE, TOP, HEAD COVER
24	F70339	1	PATTINO MOBILE TENDICAT. PTFE	GUIDE, CAM CHAIN, ADJ, LARGE
25	F70354	1	TENSIONATORE AUTOMATICO 07/->	AUTOMATIC CHAIN TENSIONER 2007
26	12012	1	O RING TENDICATENA 4T	O RING CHAIN TENSIONER 4S
27	49484	2	VITE TCEI 6X20	BOLT TCEI 6X20
28	F49826	1	BOCCOLA VITE SPEC.FIS.PAT.MOB.	BUSH SPEC. BOLT



4T530FIMX21-M
MOTORE - ENGINE

DISTRIBUZIONE
VALVES COVER

3

29	49407	1	VITE TSEI 6X25	BOLT TSEI 6X25
30	F70345	1	CATENA LAR. DISTRIBUZIONE P130	CAM CHAIN, 130L
31	49603	1	RONDELLA M 6,4 X 12 X 1,6	WASHER 6x12
32	49399	1	VITE TSEI 5X12	BOLT TSEI 5x12
33	F70338	1	PATTINO FISSO FRES. X CAT.LARG	GUIDE, CAM CHAIN, FIXED, LARGE
34	F65104	1	TUBO COPOLAN GRIGIO 11x16	HOSE COPOLAN GREY 11X16mm
35	F26317	2	SEMI-ANELLO RITEGNO CUSCINETTO	RETAINER, CAM BEARING

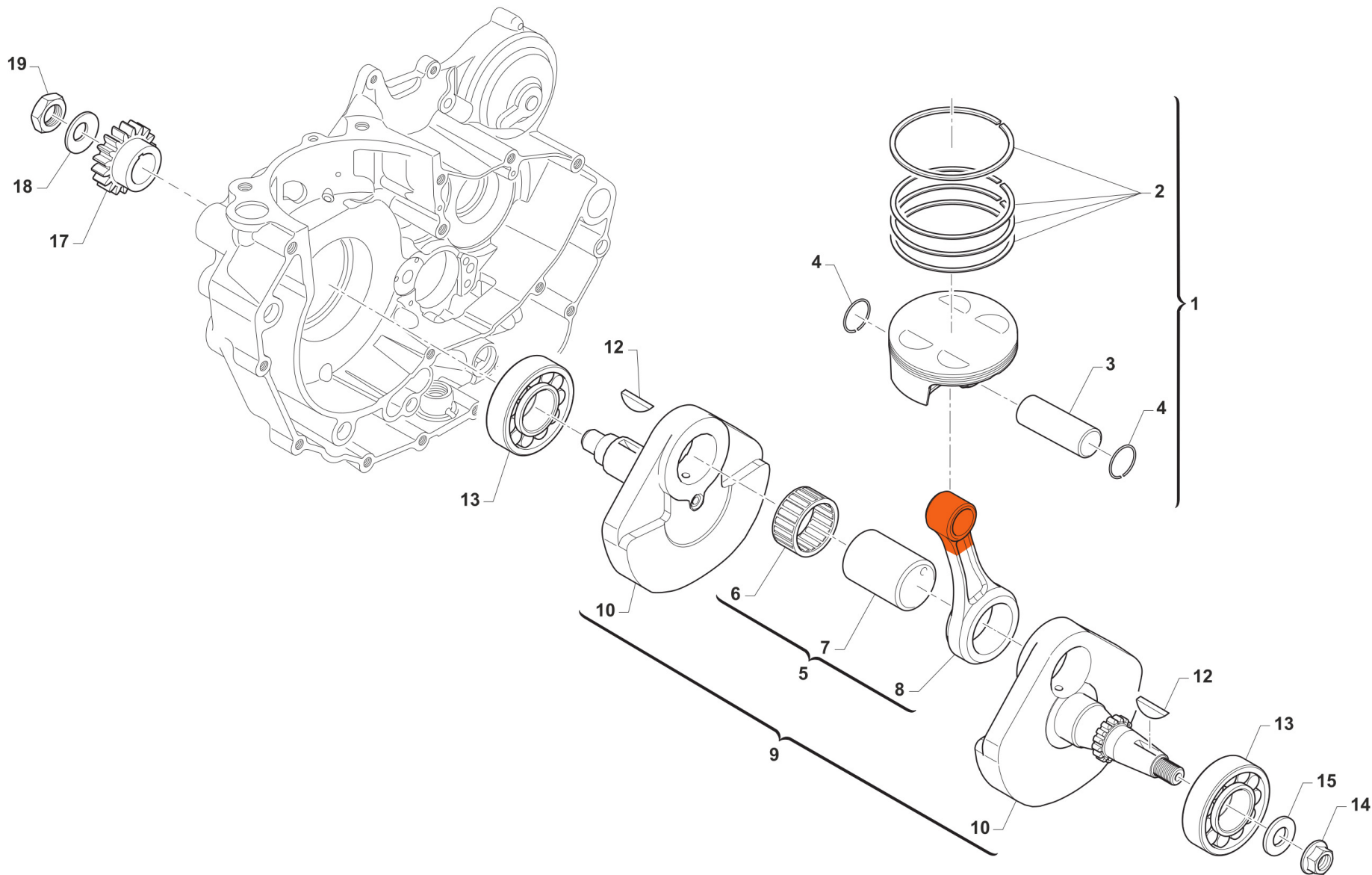

TM0147.02



4T530FIMX21-M
MOTORE - ENGINE

ALBERO MOTORE E PISTONE
CRANKSHAFT AND PISTON

4

1	F10736.01	1	PISTONE D.98(01)CPL 530/2003	PISTON, D. 98,01 530/03 Comp.
2	F11374	1	KIT SEGMENTI D.98 W.	RINGS KIT D.98 (WISECO)
3	F09378.1	1	SPINOTTO 20X10X45 BIC.CONICO	
4	F09369	1	ANELLINI SPINOTTO D20 P COPPIA	CLIP, D20 P (TWO)
5	F18785	1	BIELLA COMPLETA 530 4T 03/-> (F18718+F18707+F17200)	CONROD ASSY 530F M.03/04
6	F17200	1	GABBIA ARGENTATA D.34 4T 400CC	SILVER CAGE D.34 400cc F.S.
7	F18772	1	ASSE D.34 X 60.8	PIN, CRANKSHAFT D.34 X 60,8mm
8	F18718	1	BIELLA INT. 118.5 4T D.42/20	ROD WHEELBASE 118,5 4S D.42/20
9	F18921	1	ALBERO MOTORE CPL 530 Fi	CRANKSHAFT ASSY 530Fi SMX
10	F18921.1	1	COPPIA SEMIALBERO 530 Fi	
12	49012	2	CHIAVETTA PIGNONE COPPIA 250	WOODRUFF KEY, 250/300 19x7,5x5
13	F03352	2	CUSCINETTO 6306/C3E BANCO450cc	BUSH, CRANKSHAFT 400F 6306
14	49056	1	DADO ACCENS 100/TAG/KZ 125MX/E	NUT, IGNITION 100cc
15	49613	1	RONDELLA ACCIAIO 12	STEEL WASHER 12
17	F40820	1	PIGNONE C.PRIMARIA Z21 4T	PRIMARY DRIVE GEAR F.S. 21T
18	F49917	1	MOLLA A TAZZA 40X20.4X1	SPRING, 40X20.4X1
19	F49916	1	DADO ALBERO MOTORE 20X1.5 4T	NUT, CRANKSHAFT 20X1.5 4 Str.

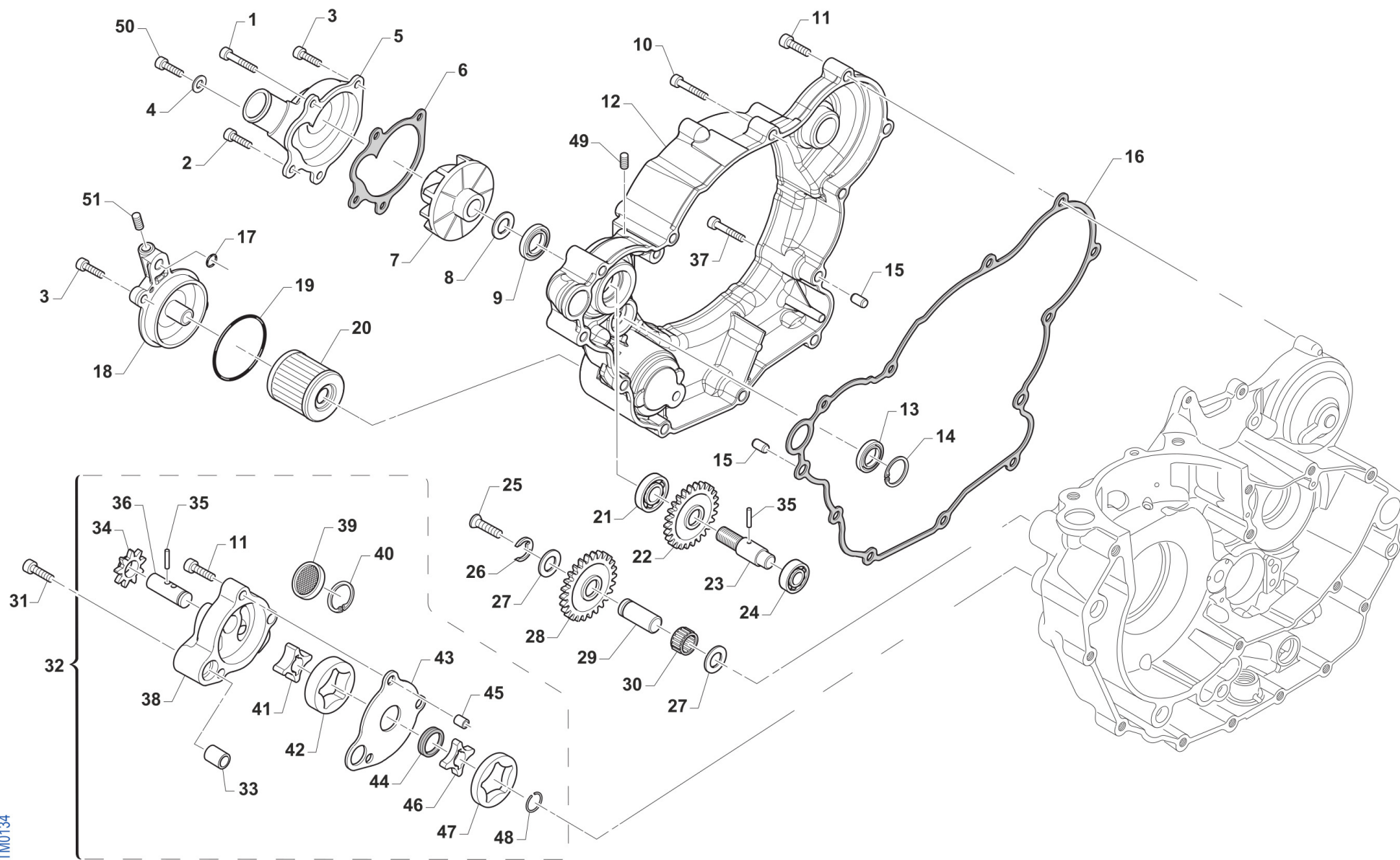

TM0134



4T530FIMX21-M
MOTORE - ENGINE

LUBRIFICAZIONE
LUBRIFICATION

1	49570	1	VITE TCEI 5X50 UNI 5931	SCREW TCEI 5X50
2	49578	1	VITE TCEI 5X55	BOLT TCEI 5X55
3	49476	4	VITE TCEI 5X20 UNI 5931	BOLT TCEI 5X20
4	49104	1	RONDELLA 6 x 10 x 1,5 ALLUMINIO	WASHER 6 x 10 x 1.5 ALUMINUM
5	F30796	1	COPERCHIO POMPA ACQUA 4T 04	COVER, WATER PUMP 4S 04/->
6	F05822	1	GUARNIZIONE COP.POMPA ACQUA PF	GASKET, COVER WATER PUMP PF
7	F28661	1	GIRANTE POMPA ACQUA 4T MOD.08	IMPELLER, H2O 4S M. 08/->
8	49603	1	RONDELLA M 6,4 X 12 X 1,6	WASHER 6x12
9	04017	1	PARAOLIO CENTRIFUGA 06 +MF1TAG	OIL SEAL 8 X 22 X 7 TC
10	49485	1	VITE TCEI 6X25 UNI 5931	BOLT TCEI 6x25
11	49486	9	VITE TCEI 6X30 UNI 5931	BOLT TCEI 6X30
12	F30979	1	CARTER EST.TRASM./FRIZ. 4T MY 12->	COVER,TRAN./CLUTCH 450 4S 12->
13	F04352	1	PARAOLIO 14-22-4 TIPO A 4T	OIL SEAL 14-22-4 TYPE A F.S.
14	F49913	1	SEEGER I 23	CIRCLIP INT. 23
15	F26304	2	GRANO RIFERIMENTO 6.5X8X9.5 4T	GRUB SCREW 6.5X8XX9.5 4S
16	F05821	1	GUARNIZIONE COPERC.TRASMIS. PF	GASKET, CLUTCH COVER INT 04/->
17	F12302	1	O RING 108 PIOGGIA CAMBIO 4T	O-RING, 108 GEAR F.S.
18	F30965	1	COPERCHIO FILTRO OLIO 250Fi 11	CAP, OIL FILTER 250Fi 11->
19	12094	1	O RING COP. FILTRO OLIO	O RING OIL FILTER COVER
20	F66510	1	FILTRO OLIO 4Tempi HF 141	OIL FILTER HF - 141
21	F03351	1	CUSCINETTO 6001 POMPA ACQUA 4T	BUSH, WATER PUMP 4S 6001
22	F40824	1	INGRANAGGIO POMPA ACQUA Z19 4T	WATER PUMP GEAR 19T F.S.
23	F28660	1	ALBERINO POMPA ACQUA 4T D.8	AXLE WATER PUMP F.S. D.8mm
24	F03350	1	CUSCINETTO POMPA ACQUA 4T	BUSH, WATER PUMP F.S. 6000 C3
25	49429	1	VITE TSEI 4X35	BOLT TSEI 4X35
26	F49903	1	ANELLO ELASTICO RA 9 DIN 6799 4T	CIRCLIP RA 9 DIN 6799 4S
27	19021	2	RONDELLA X GABBIA RULLI AS1024	WASHER, NEEDLE CAGE AS 1024
28	F40834	1	RUOTA DENTATA FOLLE Z 25	GEAR FREE T25



4T530FIMX21-M
MOTORE - ENGINE

LUBRIFICAZIONE
LUBRIFICATION

29	F28501	1	ALBERINO RUOTA FOLLE P.OLIO 4T	
30	F19501	1	GABBIA A RULLI 10X13X10 4T	NEEDLE CAGE 10X13X10 F.S.
31	49488	1	VITE TCEI 6X40	BOLT TCEI 6x40
32	F32508.530	1	POMPA OLIO COMPLETA 4T 530	
33	F26303	1	BOCCOLA RIFERIMENTO 12X10 4T	COLLAR 12X13 F.S.
34	F40835	1	INGRANAGGIO POMPA OLIO Z12	OIL PUMP GEAR 12T
35	F19500	3	RULLO D.3 X 17.8 4T	PIN D.3 X 17,8 F.S.
36	F28533	1	ALBERINO POMPA OLIO MOD.03	SHAFT, OIL PUMP M.2003
37	49487	1	VITE TCEI 6X35 UNI 5931	BOLT TCEI 6X35
38	F30706	1	POMPA OLIO 4T NUDA	ROTOR HOUSING 250/400 F.S.
39	F32500	1	FILTRO LAMIERA ASP.POMPA OLIO	OIL SCREEN
40	F49915	1	SEEGER I28 FILTRO COPPA OLIO (J28 x fori)	SEEGER OIL FILTER
41	F32503	1	ROTORE INT. ALTO POMPA OLIO 4T	INTERNAL OILPUMP ROTOR H.
42	F32502	1	ROTORE EST. ALTO POMPA OLIO 4T	EXTERNAL OILPUMP ROTOR H.
43	F32501	1	SEPARATORE POMPE OLIO 4T	SEPARATOR OIL PUMPS 4S
44	F04354	1	PARAOLIO G 12X16X3 POMPA OLIO	OIL SEAL G 12/13/3 OIL PUMP
45	26041	1	GRANO CENTRAGGIO D.7X8 F.5,2	DOWEL PIN 7 x 8 Hole 5,2
46	F32514	1	ROTORE INT.POMPA MANDATA H6mm	INTERNAL OILPUMP ROTOR
47	F32513	1	ROTORE EST.POMPA MANDATA H6mm	EXTERNAL OILPUMP ROTOR
48	F49902	1	SEEGER WR 12 4T - FIG. K11/K12	CIRCLIP WR 12
49	49711	1	GRANO 6X 6	
50	49480	1	VITE TCEI 6X10 UNI 5931	BOLT TCEI 6X10
51	49702	1	GRANO 5X 6 VALV.SC.MARTELLETTO	GRUB SCREW 5 X 6 INLET VALVE

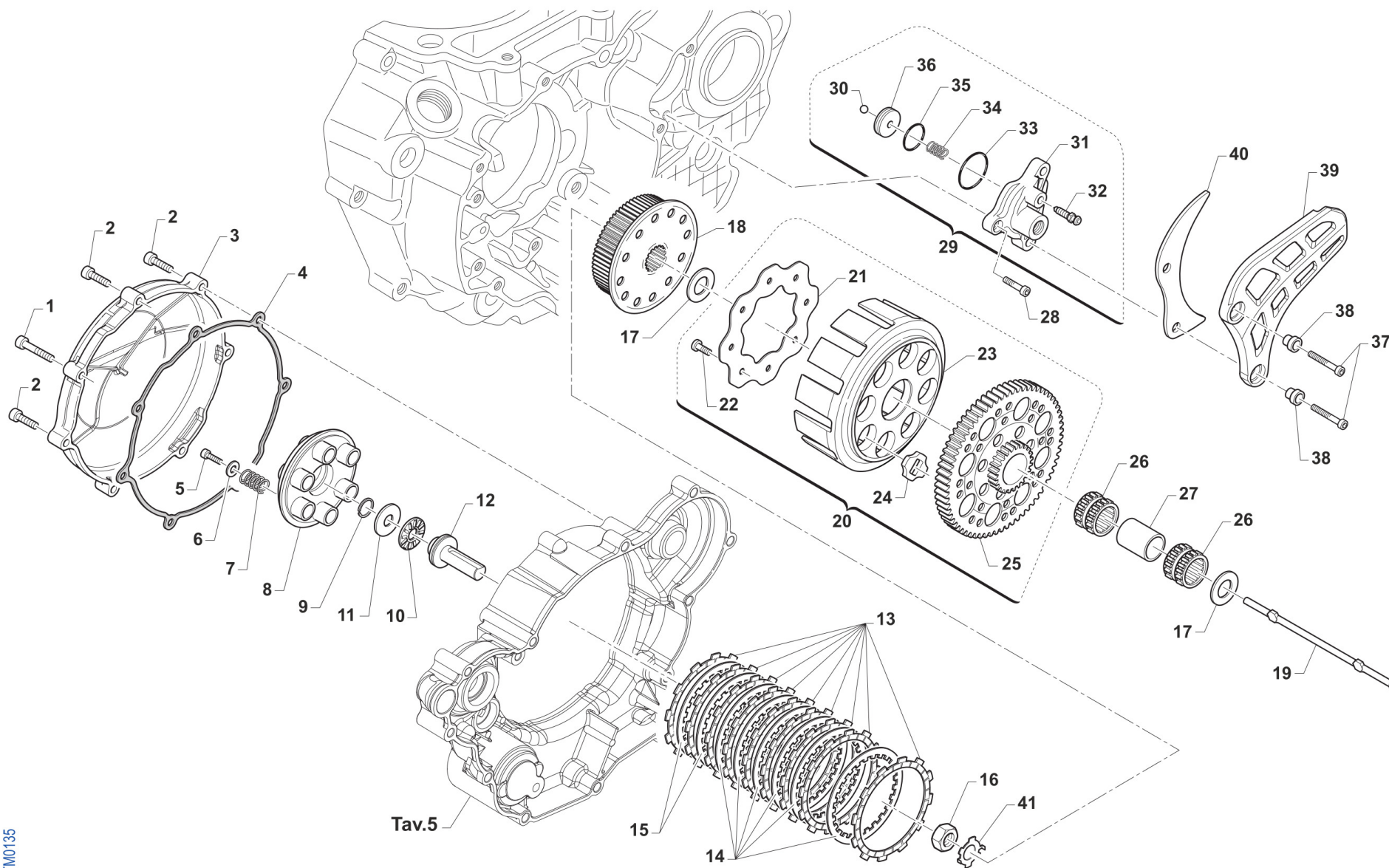



4T530FIMX21-M
MOTORE - ENGINE

FRIZIONE
CLUTCH

1	49576	1	VITE TCEI 5X70	BOLT TCEI 5X70
2	49477	6	VITE TCEI 5X25 UNI 5931	BOLT TCEI 5X25
3	F30795	1	COPERCHIO FRIZIONE 4T 04 ALTO	CLUTCH COVER 4 STR.M.04 HIGH
4	F05820	1	GUARNIZ. EST. COPERCHIO FRIZ.	GASKET, CLUTCH COVER EXT 04/->
5	49355	6	VITE TE F/R 6X16 Ch.8	BOLT 6X16 T.8
6	49604	6	RONDELLA 6 X18 X 1,6	WASHER 6x18
7	F16453	6	MOLLA FRIZIONE 2/4T 250/450	SPRING, CLUTCH 2/4T 250/450
8	25253	1	PIATTO SPING. 250/300 + 4T	PLATE, CLUTCH PRESSURE
9	09006	1	ANELLINO FERMA SPINOTTO 80/85/100	CLIP, PISTON PIN 80/85/100cc
10	19022	1	GABBIA A RULLI RAD. AXK 1528	BUSH CAGE AXK 1528, RADIAL
11	19023	1	RONDELLA GABBIA RULLI AS 1528	WASHER, NEEDLE CAGE AS 1528
12	F35582	1	FUNGO FRIZIONE IDRAULICA 2015	PIECE, CLUTCH LIFTER
13	F35567	9	DISCO FRIZ. GUARN. ADLER 2,75	CLUTCH PLATE, FIBER ADLER 2,75
14	35250	6	DISCO FRIZ. ACC. 1,8 mm 250+4T	CLUTCH PLATE, STEEL 1,8mm 250
15	35254	2	DISCO FRIZ. ACC. 1,5 mm 250+4T	CLUTCH PLATE, STEEL 1,5mm94/98
16	49060	1	DADO TAMBUR.FRIZ. ALB.PRIM. 250/300 M18X1.5	NUT, CLUTCH CENTER 250cc
17	48250	2	SPESSORE COPPIA PRIMARIA 250	SPACER, PRIMARY GEAR 250cc
18	F25255	1	TAMBURELLO FRIZ. ALTO 4T	HIGH CLUTCH CENTER 530/600F
19	F35578	1	ASTINA FRIZIONE IDRAULICA 450F	PIN, IDRAULIC CLUTCH 450 4S
20	F40848	1	COPPIA PRIMARIA CPL 530/600	PRIMARY DRIVE 530/600F Comp.
21	35262	1	DISCO BATTUTA GOMMINI FRIZ. 2T/4T F.6 MM	PLATE, CLUTCH BASKET 250cc
22	49202	8	CHiodo FRIZIONE K3/KV/K7 D 5,8	PIN CLUTCH K3/KV/K7/K8/K9
23	F25254	1	CAMPANA FRIZ. ALTA 4T	CLUTCH BASKET 450/530/600 HIGH
24	21005	8	GOMMINO PARASTRAPPI FRIZIONE	RUBBER, CLUTCH BASKET
25	F40833	1	CORONA TRASM.PRIM. Z53	PRIMARY GEAR T53 530cc
26	19050	2	GABBIA COPPIA FRIZIONE 250	NEEDLE CAGE CLUTCH 250cc
27	26252	1	DISTANZ.GABBIA COPPIA FRIZ.250	SPACER, NEEDLE CAGE CLUTCH 250
28	49474	1	VITE TCEI 5X16 UNI 5931	BOLT TCEI 5X16



4T530FIMX21-M
MOTORE - ENGINE

FRIZIONE
CLUTCH

6

29	F30029	1	COP. FRIZ/IDR 450/530 2015 CPL	COVER IDR. CLUTCH 450/530 M.15
30	F19517	1	SFERA X PIST.FRIZ.IDRAUL.250N	BALL IDR. CLUTCH PISTON 250N
31	F30976	1	COP. FRIZ/IDR NUDO	
32	35264	1	VITE SPURGO OLIO FRIZ.IDR.6X1	SCREW AIR BLED HYDRAUL.CLUTCH
33	12252	1	O RING PIGNONE CAT.+DIS.AL.MOT	O-RING, 25,12 x 1,78
34	F16470	1	MOLLA CONTR. PIST/FRI 450Fi'15	
35	12259	1	O RING PISTONE FR.125/250VERDE	O-RING, CLUTCH PISTON 125/250
36	F35554	1	PISTONCINO POMPA FRIZIONE	PISTON CLUTCH MASTER CYLINDER
37	49535	2	VITE TCEI 5X35 UNI 5931	BOLT TCEI 5X35
38	26211	2	BOCCOLA PROT. PIGNONE 250 F.5	COLLAR, SPROCKET 250cc H.5
39	40029	1	PROTEZIONE PIGNONE 09/-> PLAST	PROTECTION FRONT SPROCKET09/13
40	40022	1	PROTEZIONE ERGAL PIGNONE CAT.	PROTECTION, GEAR CHAIN ERGAL
41	35050	1	RONDELLA X FRIZ. 250/300/4T	CLUCTH WASHER 250/300/F

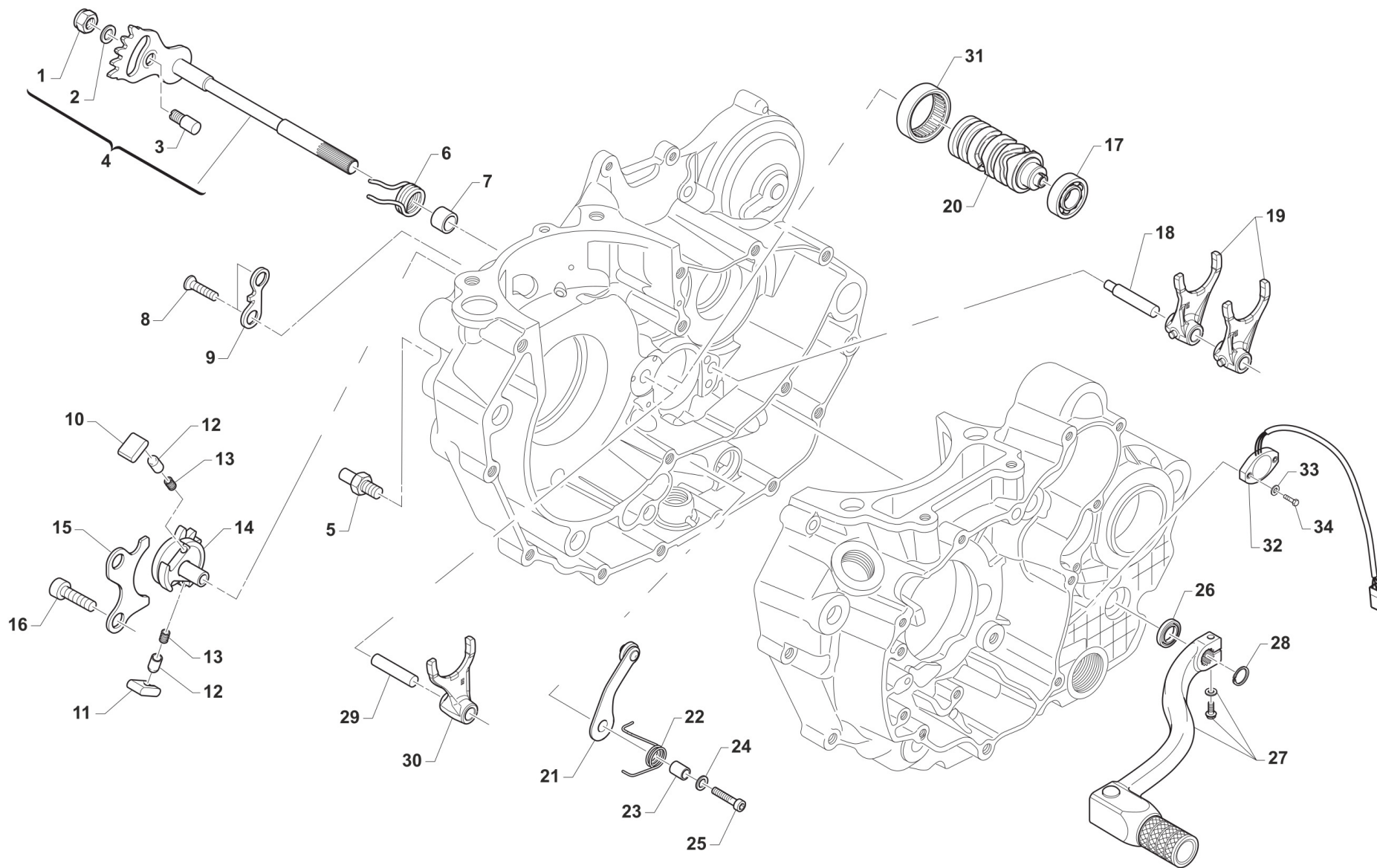

TM0136



4T530FIMX21-M
MOTORE - ENGINE

COMANDO CAMBIO
GEARSHIFT MECHANISM

1	49638	1	DADO M 6 ALTO AUTOBLOCCANTE	NUT 6mm, HIGHT SELF-LOCKING
2	49603	1	RONDELLA M 6,4 X 12 X 1,6	WASHER 6x12
3	26050	1	BATTUTA ECCENTRICA	ADJUSTER SELECTOR SHAFT
4	28100	1	ALBERO COMANDO ING. P.TACRIC.	SHAFT, GEARSHIFT
5	26051	1	BATTUTA FISSA LEVA CAMBIO INT.	PLATE INT. END STROKE GEAR LEVER
6	16009	1	MOLLA RITORNO LEVA CAMBIO 32CR	SPRING, RETURN GEAR LEVER 3,2
7	26006	1	DISTANZIALE MOLLA LEVA CAMBIO	SPACER, GEAR LEVER SPRING
8	49405	2	VITE TSEI 6X20 UMB.5933 10.9	BOLT TSEI 6x20 U.5933 10.9
9	26022	1	PIASTRINO FINE CORSA	PLATE END STROKE GEAR LEVER
10	26060	1	CRICCHETTO CAMBIO SUPERIORE	RATCHET UP, GEAR
11	26061	1	CRICCHETTO CAMBIO INFERIORE	RATCHET DOWN, GEAR
12	26062	2	PUNTALE PER CRICCHETTO CAMBIO	PIN, RATCHET GEAR
13	16012	2	MOLLA PER PUNTALE	SPRING, GEARBOX PIN
14	40310	1	INGRANAGGIO PORTACRICCHETTI	DRUM SHIFTER GEAR
15	26021	1	PIASTRINO RIENTRO CRICCHETTI	PLATE, RATCHET
16	49483	2	VITE TCEI 6X16 UNI 5931	BOLT TCEI 6X16
17	03012	1	CUSCINETTO DESMODROMICO 6001 2RS	BUSH, 6001 2RS GEAR DRUM
18	33256	1	PERNO FORCH.ALB.SEC. 250 / 125.99	AXEL, COUNTERSHAFT FORK 250cc
19	F33314	2	FORCHETTA A/S 125/250/300 CROM	SHIFT FORK SECONDARY 125/250CR
20	F33327	1	ALBERO DESMO INTEGRALE 5M SENS/CA	
21	F26479	1	PIASTRINO BLOCCA MAR. 250Fi 12	PLATE, STOP GEAR 250 4S 12->
22	F16447	1	NON UTILIZZARE !!! MOLLA BLOCCA MARCE 250Nsostituita da F16447.3	SPRING, STOP GEAR 250 4S
23	26007	1	DISTANZIALE MOLLA BLOCCAMARCE	SPACER, STOP GEAR SPRING
24	49604	1	RONDELLA 6 X18 X 1,6	WASHER 6x18
25	49485	1	VITE TCEI 6X25 UNI 5931	BOLT TCEI 6x25
26	04004	1	PARAOLIO POMPA H2O-LEVA CAMBIO	OIL SEAL 12 x 22 x 5
27	43048	1	LEVA CAMBIO 2014 + 12MM (253) 85/125/144 2T 250Fi	GEAR LEVER 2014 +12mm
28	49212	1	SEEGER E12 LEVA CAMBIO	CIRCLIP D.12 - EXTERNAL



4T530FIMX21-M
MOTORE - ENGINE

COMANDO CAMBIO
GEARSHIFT MECHANISM

29	33255	1	PERNO FORCH.ALB. PRIM.250 / 125.99	AXEL, MAINSHAFT FORK 250cc
30	F33313	1	FORCHETTA A/P 2T 250/300 CROM.	SHIFT FORK PRIM.250/300cc CROM
31	19041	1	ASTUCCIO A RULLI DHK 35/12	BUSH NEEDLE CAGE DHK 35/12
32	F08236.1	1	SENSORE POSIZ.CAMBIO RFD-4021 CABLATO	SENSOR GEAR POSITION RFD-4021 W/WIRE
33	49926	2	RONDELLA 3X9X1	WASHER 3 X 9 X 1
34	49922	2	VITE TE 3X14	

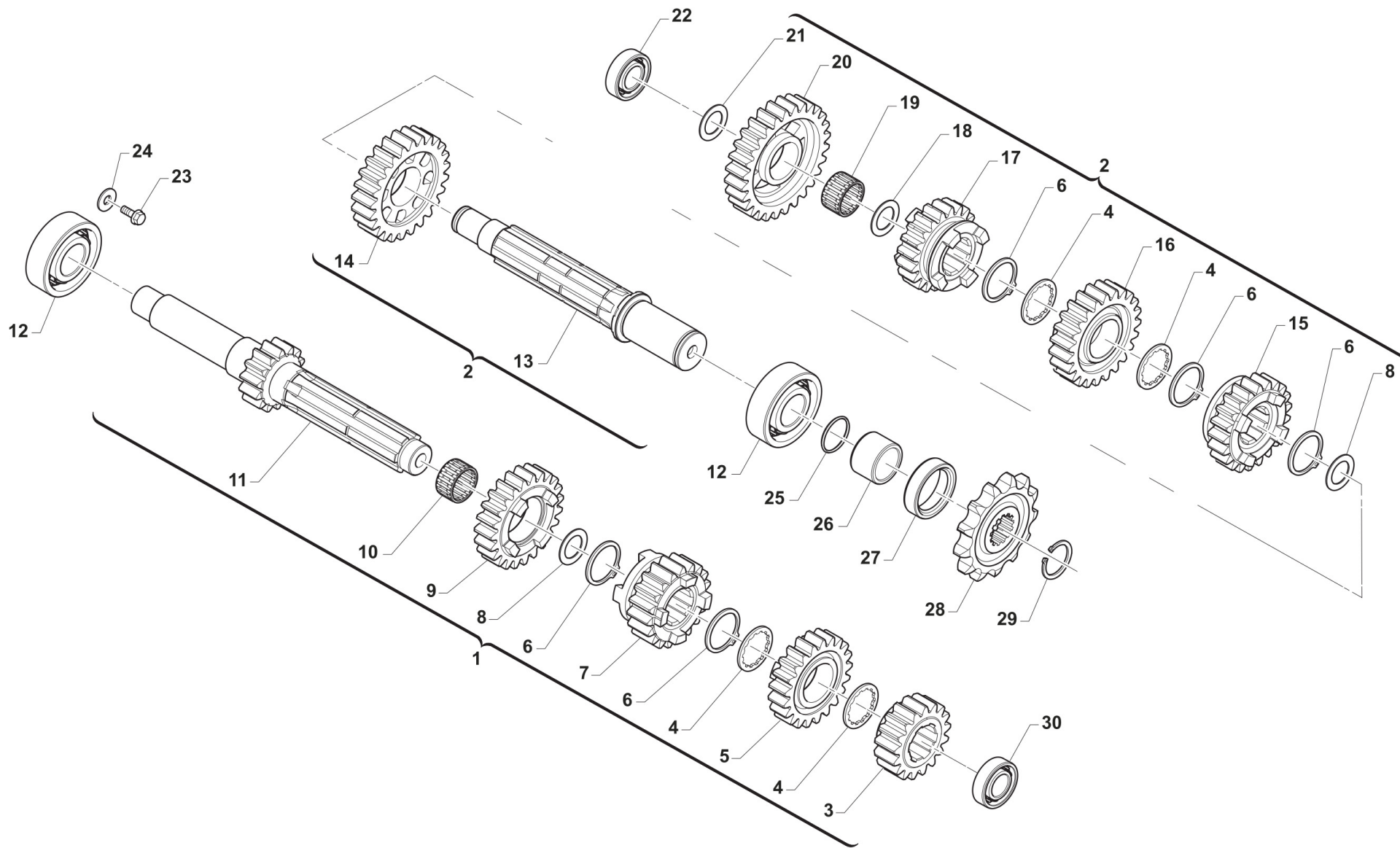



4T530FIMX21-M
MOTORE - ENGINE

CAMBIO
GEAR BOX

1	F40934.1	1	ALBERO PRIM. CPL 450/530 MX	
2	F40935.1	1	ALBERO SEC. CPL 450/530 MX	
3	F40877	1	INGRAN A.P. 2a Z 17 X Z24	GEAR, 2TH (17T) for (24T)
4	48251	4	SPESSORE DENT.CAMBIO 250/KZ10B	SPACER, GEAR 250cc
5	40260	1	INGRAN A.P. 4a Z 21 250 CR/E	GEAR, 4TH (21T) MAINSHAFT MX/E
6	49255	5	SEEGER RETTIFICATO CAMBIO 250	CIRCLIP, GEAR BOX 250cc
7	F40906	1	INGRAN A.P. 3a Z 16	GEAR, 3RD (16T) MAINSHAFT
8	48254	2	SPE.SRE CAMBIO 25.2X31.8X1 250	SPACER,GEAR BOX250 25.2X31.8X1
9	40262	1	INGRAN A.P. 5a Z 23 250/CROSS	GEAR, 5TH (23T) MAINSHAFT MX
10	19051	1	GABBIA ING. V AP. 250	NEEDLE CAGE K 25x29x10 AP250
11	F40873	1	ALBERO PRIMARIO Z16	MAINSHAFT 16T (4 Stroke)
12	03252	2	CUSCINETTO 6205 C4 A/P 250/K9	BUSH, MAINSHAFT 250 / KZ
13	40270	1	ALBERO SECONDARIO 250/450	COUNTERSHAFT 250cc
14	F40878	1	INGRAN A.S. 2a Z 24 2V	GEAR, 2ND (24T) COUNTERSHAFT
15	40279	1	INGRAN A.S. 4a Z 21 250 CR/E	GEAR, 4TH(21T)COUNTER.MX/E 250
16	F40907	1	INGRAN A.S. 3a Z 19	GEAR, 3RD (19T) COUNTERSHAFT
17	40281	1	INGRAN A.S. 5a Z 20 250/CROSS	GEAR, 5TH(20T)COUNTERSH.MX 250
18	48252	1	SPESSORE CAMBIO 20X29X1 250	SPACER, GEAR 250 20X29X1
19	19012	1	GABBIA A RULLI K 20X24X10	BUSH NEEDLE CAGE 20 X 24 X 10
20	F40874	1	INGRAN A.S. 1a Z 27 X A.P.Z16	GEAR, 1ST (27T) COUNTERSHAFT
21	48253	1	SPESSORE CAMBIO 17X30X1 250	SPACER, GEAR BOX 250cc 17X30X1
22	03251	1	CUSCINETTO 6203/C3 A/P A/S 250	BUSH, MAINSHAFT COUNTER.250/4T
23	49480	1	VITE TCEI 6X10 UNI 5931	BOLT TCEI 6X10
24	49604	1	RONDELLA 6 X18 X 1,6	WASHER 6x18
25	12252	1	O RING PIGNONE CAT.+DIS.AL.MOT	O-RING, 25,12 x 1,78
26	26255	1	DISTANZIALE PIGNONE CAT.250 04	SPACER, SPROCKET DRIVE 250 04
27	04101	1	PARAOLIO PIGNONE CATENA 250	OIL SEAL 40 x 30 x 7
28	40212	1	PIGNONE CATENA Z12 250	SPROCKET 12T, DRIVE 250/300/4T



4T530FIMX21-M
MOTORE - ENGINE

CAMBIO
GEAR BOX

28	40214	1	PIGNONE CATENA Z13 250/2T e 4T	SPROCKET 13T, DRIVE 250/300/4T
28	F40925	1	PIGNONE CATENA Z14 O/S 2MM	SPROCKET 14T, DRIVE 4S O/S 2mm
29	49252	1	SEEGER PIGNONE CATENA 250 E 25	CIRCLIP D.25 FRONT SPROKET 250
30	03254	1	CUSCINETTO A.P.4 Tempi 2RS1/C3	BUSH, MAINSHAFT 2RS/C3 4S



4T530FIMX21-M
MOTORE - ENGINE

MESSA IN MOTO
KICK STARTER

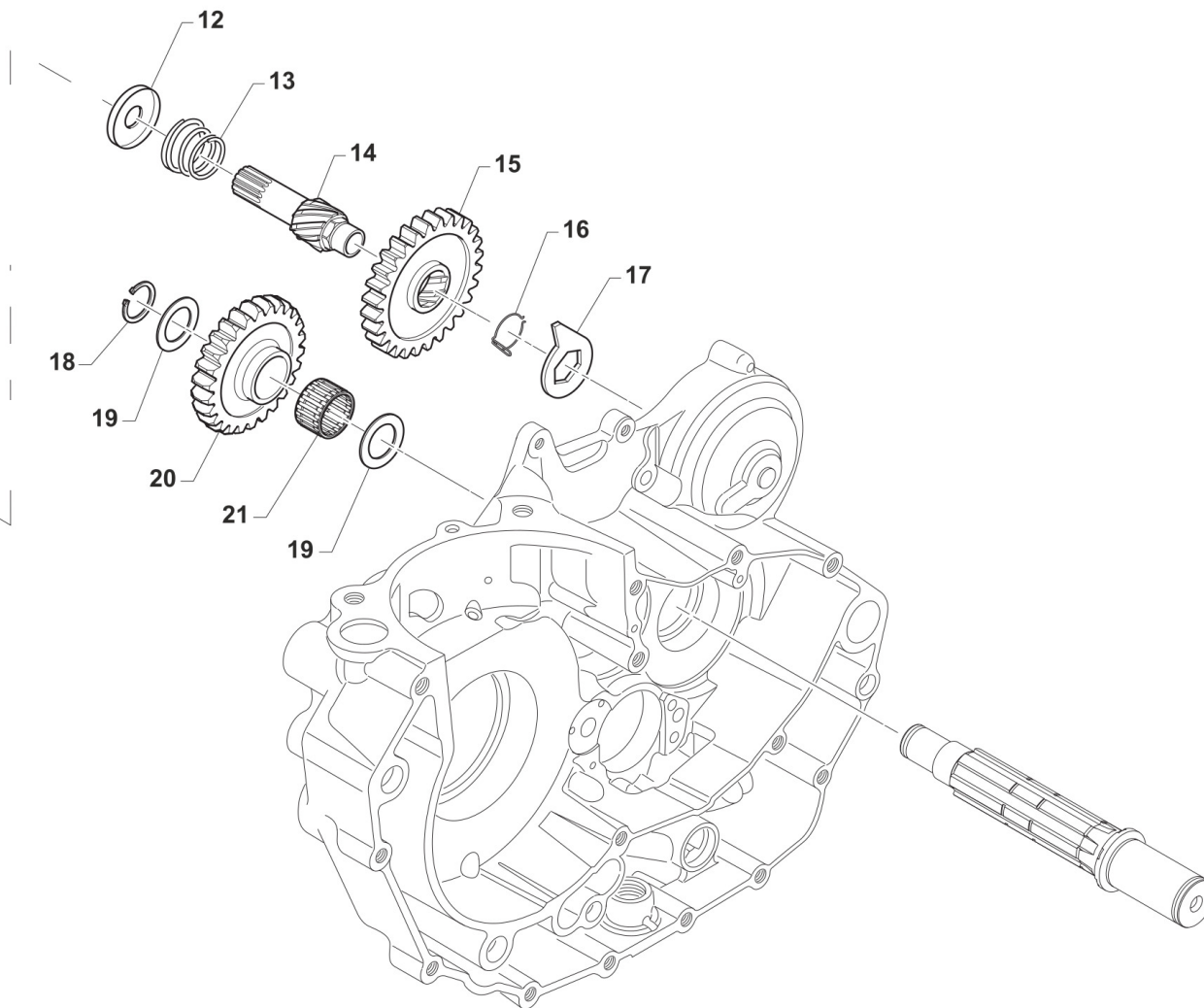
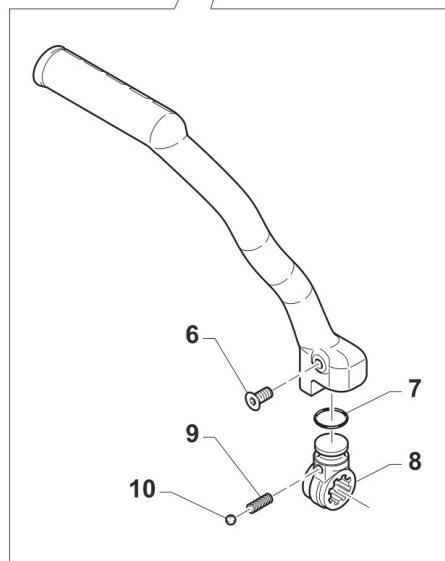
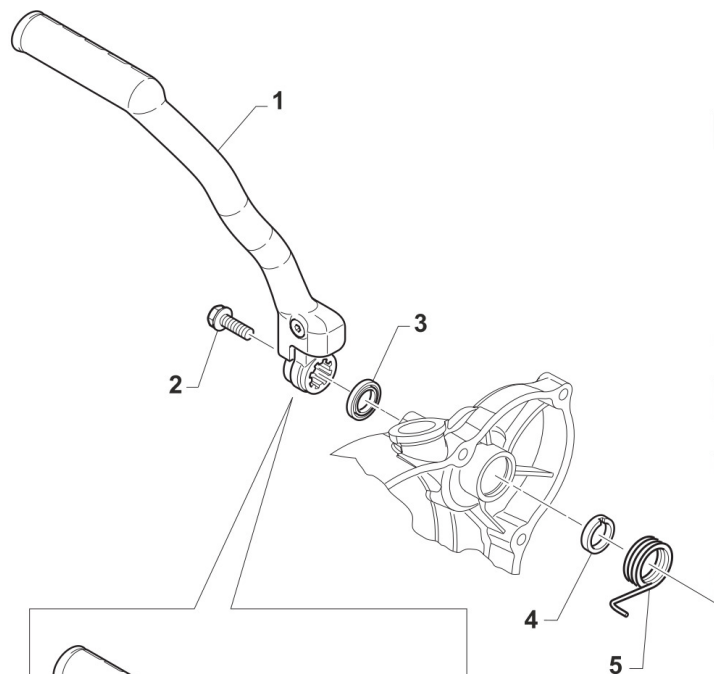

TM0133



4T530FIMX21-M
MOTORE - ENGINE

MESSA IN MOTO
KICK STARTER

1	43250.12	1	LEVA M/M 250/300 M. 2012	LEVER, KICK STARTER 250 94/->
2	49369	1	VITE TE F/R 8X10 Ch.10 M/M	BOLT 8X10 T.10mm(Kich Starter)
3	04102	1	PARAOLIO LEVA M/M 250	OIL SEAL 30 x 20 x 7
4	26253	1	DISTANZIALE MOLLA M/M 250 CC	SPACER, KICK START.SPRING 250
5	16253	1	MOLLA M/M 250/300 + 4T	SPRING, KICK STARTER 250/300
6	49406	1	VITE TSEI 6X20	BOLT TSEI 6x20
7	12260	1	O RING INTERNO LEVA M/M 250	O-RING INT.LEVER KICK START250
8	F43360	1	MOZZETTO MESSA IN MOTO 4T 03	KICK STARTER BLOCK F.S. 03->
9	16039	1	MOLLA X SFERA LEVA M/M 250 CC	SPRING, BALL KICK-START. 250cc
10	43250.03	1	SFERA 1/4C X LEVA M/M 250 CC	BALL, KICK STARTER LEVER 250cc
12	F26399	1	PIATTELLO MOLLA CONTRASTO M/M	
13	F16416	1	MOLLA DI CONTRASTO M/M 4T	SPRING K.STARTER 4S
14	F28508.2	1	ALBERO M/M 250/400 4T NT	SHAFT, KIK STARTER 250/400 F.S
15	F40831	1	INGRANAGGIO SCORREVOLE M/M 530	SLIDING GEAR, KICK START. 530F
16	16254	1	MOLLA X INGRANAGGIO M/M 250	SPRING,KICKSTART SLID.GEAR 250
17	26254	1	LEVA BATTUTA M/M 125/250 96/->	STOPPER, KICK STARTER
18	49253	1	SEEGER E17 INGR.FOLLE M/M 250	CIRCLIP, INTERMED.GEAR K.S.250
19	48012	2	RASAMENTO A/S M/M SPESS.0,5	SPACER, 26x17x0,5
20	F40832	1	INGRANAGGIO FOLLE M/M Z26	INTERMEDIATE GEAR K.S. 26T
21	19011	1	GABBIA A RULLI K 17X21X10	BUSH CAGE 17 X 21 X 10

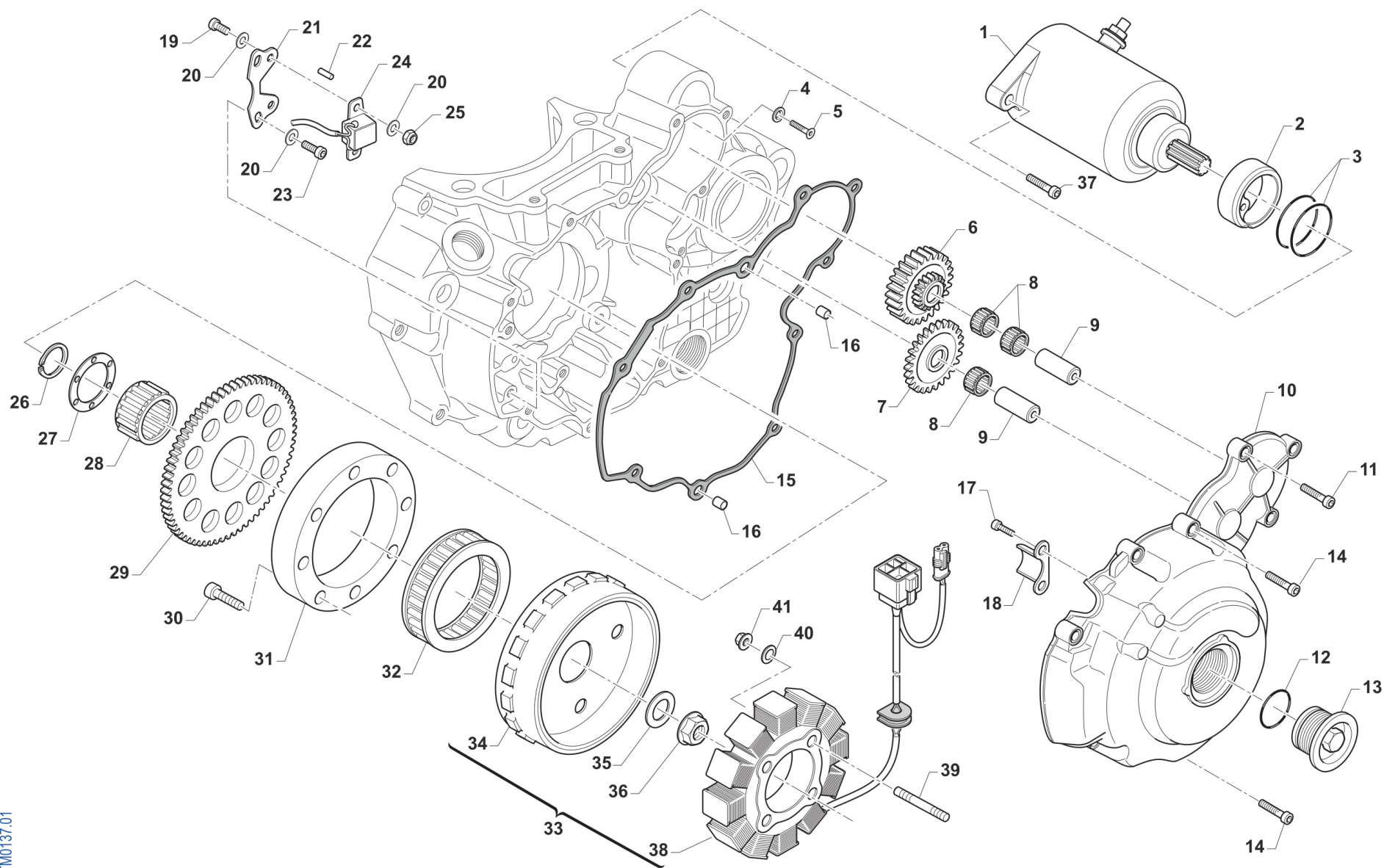

TM0137.01



4T530FIMX21-M
MOTORE - ENGINE

ACCENSIONE ES
IGNITION ES

10

1	F68100	1	MOTORINO AVVIAMENTO 4T SM14233	E-STARTER ENGINE ASSY 4 S
2	F26341	1	BOCCOLA CENTRAGGIO MOT.AVVIAM.	COLLAR, EL. STARTER
3	F12309	2	O RING 2150	O-RING, 2150
4	49675	1	RONDELLA 7	
5	49399	1	VITE TSEI 5X12	BOLT TSEI 5x12
6	F40839	1	INGRANAGGIO DOPPIO RINF. E.S.	GEAR, ELECT. START
7	F40808	1	INGR. FOLLE AVVIAMENTO EL.	INTERMEDIATE GEAR
8	F19501	3	GABBIA A RULLI 10X13X10 4T	NEEDLE CAGE 10X13X10 F.S.
9	F28568	2	ALBERINO LUNGO ING. AVV.ELETRR	SHAFT, EL. STARTER GEAR
10	F30948	1	COP. ACC. 450Fi MX/SMX ES	COVER, IGNITION 450Fi MX/SM ES
11	49476	8	VITE TCEI 5X20 UNI 5931	BOLT TCEI 5X20
12	F12322	1	O RING 2106	O-RING
13	F49833	1	TAPPO COPERCHIO ACC.250Fi	COVER CAP ALUMINIUM 250Fi
14	49477	2	VITE TCEI 5X25 UNI 5931	BOLT TCEI 5X25
15	F05823	1	GUARNIZIONE COP.STATORE E.S.PF	GASKET, IGNITION COVER ES PF
16	26041	2	GRANO CENTRAGGIO D.7X8 F.5,2	DOWEL PIN 7 x 8 Hole 5,2
17	49593	2	VITE TCEI 4X8 U.	BOLT TCEI 4X8 U.
18	F30708	1	PROTEZIONE CAVI ACCENSIONE	
19	49435	2	VITE TE 5X12	SCREW TE 5X12
20	49678	6	RONDELLA 5 x 10 x 1	
21	F15554	1	PIASTRINO SUPPURTO PICKUP DOPPIO FORO	
22	F19504	1	RULLO D.4 X 8	PIN D.4 X 8
23	49474	2	VITE TCEI 5X16 UNI 5931	BOLT TCEI 5X16
24	F15478	1	PICK-UP KOKUSAN	PICK-UP KOK PU5157
25	49633	2	DADO M 5 BASSO AUTOBLOCCANTE	NUT 5mm, LOW SELF-LOCKING
26	F49937	1	SEEGER ALBERO E 36 4T	CIRCLIP 36 CRANKSH. E 4S
27	F26327	1	RONDELLA ACC. 37X53X2 4T	WASHER 37X50X2 4S.
28	F19506	1	GABBIA A RULLI AVV.EL.37X42X17	NEEDLE CAGE 37X42X17 E.S.



4T530FIMX21-M
MOTORE - ENGINE

ACCENSIONE ES
IGNITION ES

10

29	F40807	1	INGR. CONDOTTO AVVIAMENTO EL.	GEAR EL. STARTER
30	F49929	8	VITE TCE BASSA 6X16 (CL. 12.9)	SCREW TCE 6 X 16
31	F26385	1	ANELLO ESTERNO PESANTE R.L.KOK	EXTERNAL RING IGNITION KOKUSAN
32	F03354	1	RUOTA LIBERA MOTORINO AVV. 4T	FREE-WHEEL ELECTRIC STARTER
33	F15561	1	GENERATORE KOKUSAN MX E.S. KOK / SUMIT. 2V	GENERATOR KOKUSAN MX E.S.
34	F15549	1	ROTORE KOKUSAN YF9019	ROTOR, KOKUSAN YF9019
35	49613	1	RONDELLA ACCIAIO 12	STEEL WASHER 12
36	49056	1	DADO ACCENS 100/TAG/KZ 125MX/E	NUT, IGNITION 100cc
37	49484	2	VITE TCEI 6X20	BOLT TCEI 6X20
38	F15547	1	STATORE KOKUSAN YS 9018 C. KOK / SUM	
39	F49836	4	PRIGIONIERO M5/M4 STATORE KOK.	
40	49686.2	4	RONDELLA ZIGRINATA 4 X 0,50 (ACCENSIONE 4T)	
41	49631	4	DADO M 4 BASSO AUTOBLOCCANTE	NUT 4mm, LOW SELF-LOCKING

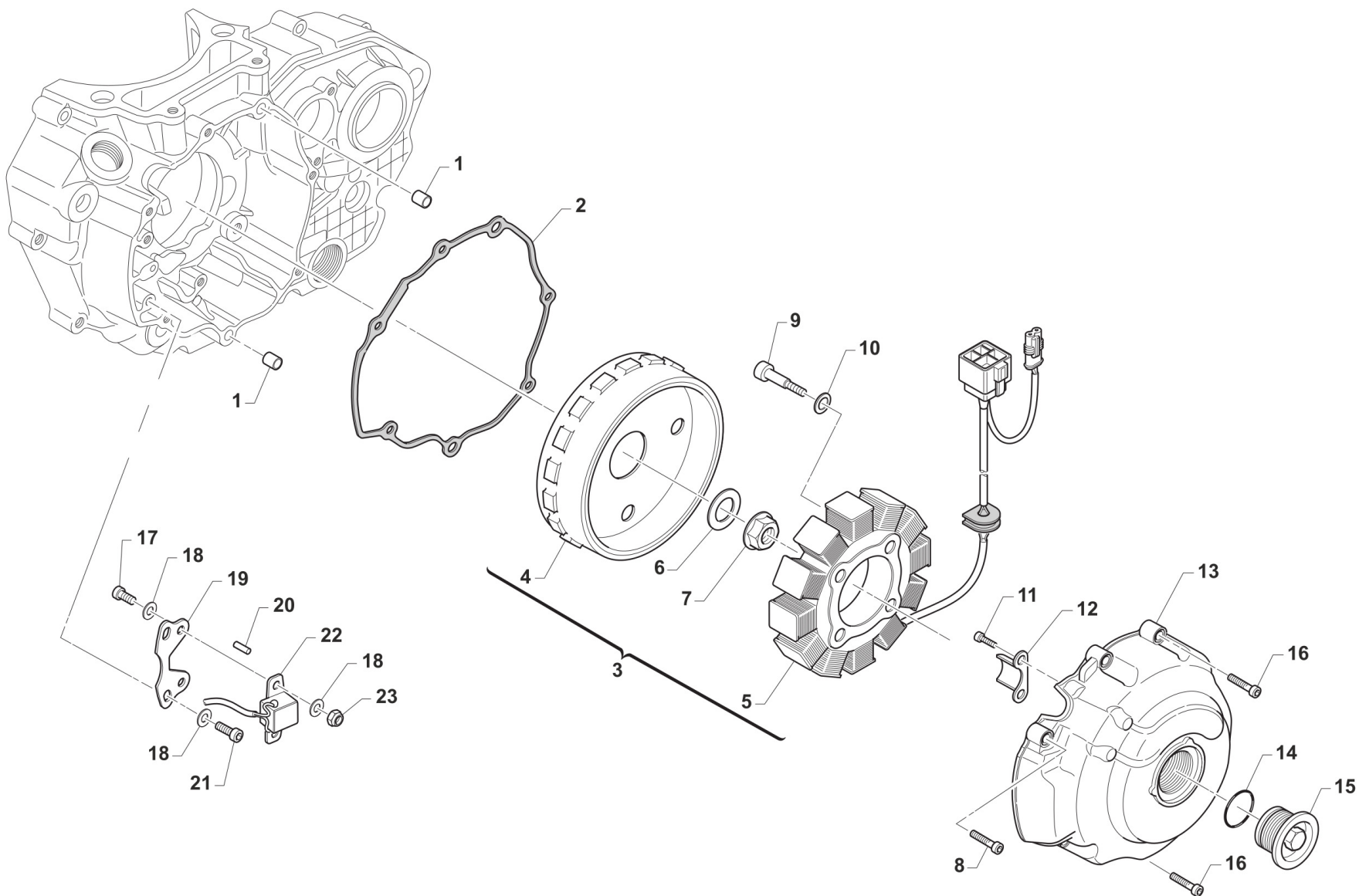



4T530FIMX21-M
MOTORE - ENGINE

ACCENSIONE KS
IGNITION KS

1	26041	2	GRANO CENTRAGGIO D.7X8 F.5,2	DOWEL PIN 7 x 8 Hole 5,2
2	F05824	1	GUARNIZIONE COP.STAT.ACC.F PF	GASKET, IGNITION COVER KS 04/>
3	F15560	1	GENERATORE KOKUSAN D.88 K.S. KOK / SUM	ACG KOK D.88 KS GP9018 CPL
4	F15547	1	STATORE KOKUSAN YS 9018 C. KOK / SUM	
5	F15548	1	ROTORE KOKUSAN YF9018	ROTOR KOKUSAN YF9018
6	49613	1	RONDELLA ACCIAIO 12	STEEL WASHER 12
7	49056	1	DADO ACCENS 100/TAG/KZ 125MX/E	NUT, IGNITION 100cc
8	49476	5	VITE TCEI 5X20 UNI 5931	BOLT TCEI 5X20
9	49583	4	VITE TCEI 4X30	
10	49686.2	4	RONDELLA ZIGRINATA 4 X 0,50 (ACCENSIONE 4T)	
11	49593	2	VITE TCEI 4X8 U.	BOLT TCEI 4X8 U.
12	F30708	1	PROTEZIONE CAVI ACCENSIONE	
13	F30947	1	COPERCHIO ACC. KOK.D88 KS	COVER, IGNITION KOK D.88 KS
14	F12322	1	O RING 2106	O-RING
15	F49833	1	TAPPO COPERCHIO ACC.250Fi	COVER CAP ALUMINIUM 250Fi
16	49477	2	VITE TCEI 5X25 UNI 5931	BOLT TCEI 5X25
17	49435	2	VITE TE 5X12	SCREW TE 5X12
18	49678	6	RONDELLA 5 x 10 x 1	
19	F15554	1	PIASTRINO SUPPURTO PICKUP DOPPIO FORO	
20	F19504	1	RULLO D.4 X 8	PIN D.4 X 8
21	49474	2	VITE TCEI 5X16 UNI 5931	BOLT TCEI 5X16
22	F15478	1	PICK-UP KOKUSAN	PICK-UP KOK PU5157
23	49633	2	DADO M 5 BASSO AUTOBLOCCANTE	NUT 5mm, LOW SELF-LOCKING



4T530FIMX21-M
MOTORE - ENGINE

-

03012	4T530FIAA15-M-07	17	1
03251	4T530FIMX15-M-08	22	1
03252	4T530FIMX15-M-08	12	2
03254	4T530FIMX15-M-08	30	1
04004	4T530FIAA15-M-07	26	1
04017	4T530FIAA15-M-05	9	1
04036	4T530FIAX15-M-01	33	1
04101	4T530FIMX15-M-08	27	1
04102	4T530FIAA15-M-09	3	1
09006	4T530FIAA15-M-06	9	1
12012	4T530FIMX15-M-03	26	1
12094	4T530FIAA15-M-05	19	1
12252	4T530FIAA15-M-06	33	1
	4T530FIMX15-M-08	25	1
12259	4T530FIAA15-M-06	35	1
12260	4T530FIAA15-M-09	7	1
16009	4T530FIAA15-M-07	6	1
16012	4T530FIAA15-M-07	13	2
16039	4T530FIAA15-M-09	9	1
16253	4T530FIAA15-M-09	5	1
16254	4T530FIAA15-M-09	16	1
19011	4T530FIAA15-M-09	21	1
19012	4T530FIMX15-M-08	19	1
19021	4T530FIAA15-M-05	27	2

19022	4T530FIAA15-M-06	10	1
19023	4T530FIAA15-M-06	11	1
19041	4T530FIAA15-M-07	31	1
19050	4T530FIAA15-M-06	26	2
19051	4T530FIMX15-M-08	10	1
21005	4T530FIAA15-M-06	24	8
25253	4T530FIAA15-M-06	8	1
26006	4T530FIAA15-M-07	7	1
26007	4T530FIAA15-M-07	23	1
26021	4T530FIAA15-M-07	15	1
26022	4T530FIAA15-M-07	9	1
26041	4T530FIAA15-M-05	45	1
	4T530FIAX15-M-10	16	2
	4T530FIAX15-M-11	1	2
26050	4T530FIAA15-M-07	3	1
26051	4T530FIAA15-M-07	5	1
26060	4T530FIAA15-M-07	10	1
26061	4T530FIAA15-M-07	11	1
26062	4T530FIAA15-M-07	12	2
26211	4T530FIAA15-M-06	38	2
26252	4T530FIAA15-M-06	27	1
26253	4T530FIAA15-M-09	4	1
26254	4T530FIAA15-M-09	17	1
26255	4T530FIMX15-M-08	26	1
28100	4T530FIAA15-M-07	4	1
33255	4T530FIAA15-M-07	29	1
33256	4T530FIAA15-M-07	18	1

35050	4T530FIAA15-M-06	41	1
35250	4T530FIAA15-M-06	14	6
35254	4T530FIAA15-M-06	15	2
35262	4T530FIAA15-M-06	21	1
35264	4T530FIAA15-M-06	32	1
40022	4T530FIAA15-M-06	40	1
40029	4T530FIAA15-M-06	39	1
40212	4T530FIMX15-M-08	28	1
40214	4T530FIMX15-M-08	28	1
40260	4T530FIMX15-M-08	5	1
40262	4T530FIMX15-M-08	9	1
40270	4T530FIMX15-M-08	13	1
40279	4T530FIMX15-M-08	15	1
40281	4T530FIMX15-M-08	17	1
40310	4T530FIAA15-M-07	14	1
43048	4T530FIAA15-M-07	27	1
43250.03	4T530FIAA15-M-09	10	1
43250.12	4T530FIAA15-M-09	1	1
48012	4T530FIAA15-M-09	19	2
48250	4T530FIAA15-M-06	17	2
48251	4T530FIMX15-M-08	4	4
48252	4T530FIMX15-M-08	18	1



4T530FIMX21-M
MOTORE - ENGINE

-

48253	4T530FIMX15-M-08	21	1
48254	4T530FIMX15-M-08	8	2
49012	4T530FIAA15-M-04	12	2
49056	4T530FIAA15-M-04	14	1
	4T530FIAX15-M-10	36	1
	4T530FIAX15-M-11	7	1
49060	4T530FIAA15-M-06	16	1
49104	4T530FIAA15-M-05	4	1
49151	4T530FIMX19-M-02	18	4
49202	4T530FIAA15-M-06	22	8
49212	4T530FIAA15-M-07	28	1
49252	4T530FIMX15-M-08	29	1
49253	4T530FIAA15-M-09	18	1
49255	4T530FIMX15-M-08	6	5
49355	4T530FIAA15-M-06	5	6
49369	4T530FIAA15-M-09	2	1
49399	4T530FIAX15-M-01	7	1
	4T530FIAX15-M-10	5	1
	4T530FIMX15-M-03	32	1
49405	4T530FIAA15-M-07	8	2
49406	4T530FIAA15-M-09	6	1
49407	4T530FIMX15-M-03	29	1
49429	4T530FIAA15-M-05	25	1
49435	4T530FIAX15-M-10	19	2

	4T530FIAX15-M-11	17	2
49474	4T530FIAA15-M-06	28	1
	4T530FIAX15-M-10	23	2
	4T530FIAX15-M-11	21	2
49476	4T530FIAA15-M-05	3	4
	4T530FIAX15-M-10	11	8
	4T530FIAX15-M-11	8	5
49477	4T530FIAA15-M-06	2	6
	4T530FIAX15-M-10	14	2
	4T530FIAX15-M-11	16	2
49480	4T530FIAA15-M-05	50	1
	4T530FIMX15-M-08	23	1
49483	4T530FIAA15-M-07	16	2
49484	4T530FIAX15-M-10	37	2
	4T530FIMX15-M-03	27	2
49485	4T530FIAA15-M-05	10	1
	4T530FIAA15-M-07	25	1
49486	4T530FIAA15-M-05	11	9
49487	4T530FIAA15-M-05	37	1
	4T530FIMX19-M-02	14	8
49488	4T530FIAA15-M-05	31	1
49535	4T530FIAA15-M-06	37	2
49570	4T530FIAA15-M-05	1	1
49576	4T530FIAA15-M-06	1	1
49578	4T530FIAA15-M-05	2	1
49583	4T530FIAX15-M-11	9	4

49593	4T530FIAX15-M-10	17	2
	4T530FIAX15-M-11	11	2
49603	4T530FIAA15-M-05	8	1
	4T530FIAA15-M-07	2	1
	4T530FIMX15-M-03	31	1
49604	4T530FIAA15-M-06	6	6
	4T530FIAA15-M-07	24	1
	4T530FIAX15-M-01	8	1
	4T530FIMX15-M-08	24	1
49613	4T530FIAA15-M-04	15	1
	4T530FIAX15-M-10	35	1
	4T530FIAX15-M-11	6	1
49631	4T530FIAX15-M-10	41	4
49633	4T530FIAX15-M-10	25	2
	4T530FIAX15-M-11	23	2
49638	4T530FIAA15-M-07	1	1
49640.85	4T530FIAX15-M-01	22	2
49675	4T530FIAX15-M-10	4	1
49676	4T530FIAX15-M-01	2	2
49678	4T530FIAX15-M-10	20	6
	4T530FIAX15-M-11	18	6
49681	4T530FIAX15-M-01	1	4
49686.2	4T530FIAX15-M-10	40	4
	4T530FIAX15-M-11	10	4
49702	4T530FIAA15-M-05	51	1
49711	4T530FIAA15-M-05	49	1
49922	4T530FIAA15-M-07	34	2



4T530FIMX21-M
MOTORE - ENGINE

-

49926	4T530FIAA15-M-07	33	2
51073	4T530FIMX15-M-03	4	1
F01705	4T530FIAX15-M-01	23	1
F02860.1	4T530FIMX19-M-02	24	1
F02860.4	4T530FIMX19-M-02	25	1
F03350	4T530FIAA15-M-05	24	1
F03351	4T530FIAA15-M-05	21	1
F03352	4T530FIAA15-M-04	13	2
F03353	4T530FIMX15-M-03	18	2
F03354	4T530FIAX15-M-10	32	1
F04352	4T530FIAA15-M-05	13	1
F04354	4T530FIAA15-M-05	44	1
F04355	4T530FIAX15-M-01	14	1
F04356	4T530FIMX19-M-02	7	4
F04361	4T530FIMX15-M-03	5	1
F05820	4T530FIAA15-M-06	4	1
F05821	4T530FIAA15-M-05	16	1
F05822	4T530FIAA15-M-05	6	1
F05823	4T530FIAX15-M-10	15	1
F05824	4T530FIAX15-M-11	2	1
F05830.530	4T530FIAX15-M-01	24	1
F05843.1	4T530FIAX15-M-01	21	1
F05843.2	4T530FIAX15-M-01	21	1
F05843.3	4T530FIAX15-M-01	21	1

F05843.4	4T530FIAX15-M-01	21	1
F05846	4T530FIAX15-M-01	5	1
F06105	4T530FIMX19-M-02	23	1
F08003	4T530FIMX19-M-02	20	1
F08236.1	4T530FIAA15-M-07	32	1
F09369	4T530FIAA15-M-04	4	1
F09378.1	4T530FIAA15-M-04	3	1
F10736.01	4T530FIAA15-M-04	1	1
F11374	4T530FIAA15-M-04	2	1
F12301	4T530FIAX15-M-01	11	2
F12302	4T530FIAA15-M-05	17	1
	4T530FIAX15-M-01	10	1
F12307	4T530FIMX15-M-03	2	2
F12309	4T530FIAX15-M-10	3	2
F12311	4T530FIAX15-M-01	30	1
F12312	4T530FIAX15-M-01	29	1
F12322	4T530FIAX15-M-10	12	1
	4T530FIAX15-M-11	14	1
F13255	4T530FIMX19-M-02	17	1
F14121	4T530FIMX19-M-02	3	8
F14135	4T530FIMX19-M-02	13	2
F14136	4T530FIMX19-M-02	11	2
F15478	4T530FIAX15-M-10	24	1
	4T530FIAX15-M-11	22	1

F15547	4T530FIAX15-M-10	38	1
	4T530FIAX15-M-11	4	1
F15548	4T530FIAX15-M-11	5	1
F15549	4T530FIAX15-M-10	34	1
F15554	4T530FIAX15-M-10	21	1
	4T530FIAX15-M-11	19	1
F15560	4T530FIAX15-M-11	3	1
F15561	4T530FIAX15-M-10	33	1
F16410	4T530FIMX15-M-03	15	1
F16416	4T530FIAA15-M-09	13	1
F16447	4T530FIAA15-M-07	22	1
F16453	4T530FIAA15-M-06	7	6
F16470	4T530FIAA15-M-06	34	1
F16472	4T530FIMX19-M-02	26	2
F16473	4T530FIMX19-M-02	5	2
F17200	4T530FIAA15-M-04	6	1
F18718	4T530FIAA15-M-04	8	1
F18772	4T530FIAA15-M-04	7	1
F18785	4T530FIAA15-M-04	5	1
F18921	4T530FIAA15-M-04	9	1
F18921.1	4T530FIAA15-M-04	10	1
F19500	4T530FIAA15-M-05	35	3
F19501	4T530FIAA15-M-05	30	1
	4T530FIAX15-M-10	8	3
F19504	4T530FIAX15-M-10	22	1
	4T530FIAX15-M-11	20	1



4T530FIMX21-M
MOTORE - ENGINE

-

	4T530FIMX15-M-03	14	1
F19505	4T530FIMX15-M-03	11	1
F19506	4T530FIAX15-M-10	28	1
F19517	4T530FIAA15-M-06	30	1
F21401	4T530FIMX19-M-02	22	1
F25254	4T530FIAA15-M-06	23	1
F25255	4T530FIAA15-M-06	18	1
F26301	4T530FIAX15-M-01	25	4
F26303	4T530FIAA15-M-05	33	1
F26304	4T530FIAA15-M-05	15	2
	4T530FIMX19-M-02	15	6
F26317	4T530FIMX15-M-03	35	2
F26327	4T530FIAX15-M-10	27	1
F26337.240	4T530FIMX19-M-02	2	1
F26337.245	4T530FIMX19-M-02	2	1
F26337.250	4T530FIMX19-M-02	2	1
F26337.255	4T530FIMX19-M-02	2	1
F26337.260	4T530FIMX19-M-02	2	1
F26337.265	4T530FIMX19-M-02	2	1
F26337.270	4T530FIMX19-M-02	2	1

F26337.275	4T530FIMX19-M-02	2	1
F26337.280	4T530FIMX19-M-02	2	1
F26337.285	4T530FIMX19-M-02	2	1
F26337.290	4T530FIMX19-M-02	2	1
F26337.295	4T530FIMX19-M-02	2	1
F26337.300	4T530FIMX19-M-02	2	1
F26337.305	4T530FIMX19-M-02	2	1
F26337.310	4T530FIMX19-M-02	2	1
F26337.315	4T530FIMX19-M-02	2	1
F26337.320	4T530FIMX19-M-02	2	1
F26337.325	4T530FIMX19-M-02	2	1
F26337.330	4T530FIMX19-M-02	2	1
F26337.335	4T530FIMX19-M-02	2	1
F26337.340	4T530FIMX19-M-02	2	1
F26337.345	4T530FIMX19-M-02	2	1
F26341	4T530FIAX15-M-10	2	1
F26343	4T530FIMX15-M-03	13	1

F26344	4T530FIMX15-M-03	16	1
F26345	4T530FIMX15-M-03	12	1
F26346	4T530FIMX15-M-03	17	1
F26361	4T530FIMX19-M-02	1	4
F26377	4T530FIMX15-M-03	9	2
F26385	4T530FIAX15-M-10	31	1
F26399	4T530FIAA15-M-09	12	1
F26403	4T530FIAX15-M-01	26	1
F26428	4T530FIAX15-M-01	15	3
F26479	4T530FIAA15-M-07	21	1
F26559	4T530FIMX19-M-02	12	2
F26560	4T530FIMX19-M-02	10	2
F26565	4T530FIMX19-M-02	8	4
F26701	4T530FIMX19-M-02	4	4
F26705	4T530FIMX19-M-02	27	2
F26706	4T530FIMX19-M-02	6	2
F28501	4T530FIAA15-M-05	29	1
F28508.2	4T530FIAA15-M-09	14	1
F28515	4T530FIMX19-M-02	21	2
F28533	4T530FIAA15-M-05	36	1
F28568	4T530FIAX15-M-10	9	2



4T530FIMX21-M
MOTORE - ENGINE

-

F28598	4T530FIMX15-M-03	22	1
F28649	4T530FIMX15-M-03	10	1
F28660	4T530FIAA15-M-05	23	1
F28661	4T530FIAA15-M-05	7	1
F28688.530	4T530FIMX15-M-03	20	1
F28689.530	4T530FIMX15-M-03	7	1
F30029	4T530FIAA15-M-06	29	1
F30077	4T530FIAX15-M-01	18	1
F30078	4T530FIAX15-M-01	18	1
F30706	4T530FIAA15-M-05	38	1
F30708	4T530FIAX15-M-10	18	1
	4T530FIAX15-M-11	12	1
F30790	4T530FIMX15-M-03	1	1
F30795	4T530FIAA15-M-06	3	1
F30796	4T530FIAA15-M-05	5	1
F30832	4T530FIMX15-M-03	3	1
F30868	4T530FIMX15-M-03	6	1
F30947	4T530FIAX15-M-11	13	1
F30948	4T530FIAX15-M-10	10	1
F30965	4T530FIAA15-M-05	18	1
F30976	4T530FIAA15-M-06	31	1
F30979	4T530FIAA15-M-05	12	1
F32500	4T530FIAA15-M-05	39	1
F32501	4T530FIAA15-M-05	43	1

F32502	4T530FIAA15-M-05	42	1
F32503	4T530FIAA15-M-05	41	1
F32506	4T530FIAX15-M-01	9	1
F32508.530	4T530FIAA15-M-05	32	1
F32511	4T530FIAX15-M-01	32	1
F32512	4T530FIAX15-M-01	31	1
F32513	4T530FIAA15-M-05	47	1
F32514	4T530FIAA15-M-05	46	1
F32515	4T530FIAX15-M-01	12	1
F32523	4T530FIMX15-M-03	19	1
F33313	4T530FIAA15-M-07	30	1
F33314	4T530FIAA15-M-07	19	2
F33327	4T530FIAA15-M-07	20	1
F35554	4T530FIAA15-M-06	36	1
F35567	4T530FIAA15-M-06	13	9
F35578	4T530FIAA15-M-06	19	1
F35582	4T530FIAA15-M-06	12	1
F40807	4T530FIAX15-M-10	29	1
F40808	4T530FIAX15-M-10	7	1
F40820	4T530FIAA15-M-04	17	1
F40824	4T530FIAA15-M-05	22	1
F40831	4T530FIAA15-M-09	15	1
F40832	4T530FIAA15-M-09	20	1
F40833	4T530FIAA15-M-06	25	1
F40834	4T530FIAA15-M-05	28	1
F40835	4T530FIAA15-M-05	34	1
F40839	4T530FIAX15-M-10	6	1
F40848	4T530FIAA15-M-06	20	1

F40873	4T530FIMX15-M-08	11	1
F40874	4T530FIMX15-M-08	20	1
F40877	4T530FIMX15-M-08	3	1
F40878	4T530FIMX15-M-08	14	1
F40882	4T530FIMX15-M-03	21	1
F40883	4T530FIMX15-M-03	8	1
F40906	4T530FIMX15-M-08	7	1
F40907	4T530FIMX15-M-08	16	1
F40925	4T530FIMX15-M-08	28	1
F40934.1	4T530FIMX15-M-08	1	1
F40935.1	4T530FIMX15-M-08	2	1
F43360	4T530FIAA15-M-09	8	1
F49826	4T530FIMX15-M-03	28	1
F49833	4T530FIAX15-M-10	13	1
	4T530FIAX15-M-11	15	1
F49836	4T530FIAX15-M-10	39	4
F49902	4T530FIAA15-M-05	48	1
F49903	4T530FIAA15-M-05	26	1
F49905.1	4T530FIAX15-M-01	17	1
F49910	4T530FIMX19-M-02	9	4



4T530FIMX21-M
MOTORE - ENGINE

-

F49913	4T530FIAA15-M-05	14	1
F49915	4T530FIAA15-M-05	40	1
F49916	4T530FIAA15-M-04	19	1
F49917	4T530FIAA15-M-04	18	1
F49919	4T530FIMX19-M-02	19	2
F49920	4T530FIAX15-M-01	19	1
F49922	4T530FIAX15-M-01	27	2
F49923	4T530FIAX15-M-01	13	1
F49925	4T530FIAX15-M-01	20	1
F49926	4T530FIAX15-M-01	3	2
F49929	4T530FIAX15-M-10	30	8
F49933	4T530FIAX15-M-01	16	1
F49937	4T530FIAX15-M-10	26	1
F49972	4T530FIAX15-M-01	28	3
F49982	4T530FIAX15-M-01	6	4
F51101	4T530FIMX19-M-02	16	2
F65104	4T530FIMX15-M-03	34	1
F66510	4T530FIAA15-M-05	20	1
F68100	4T530FIAX15-M-10	1	1
F70309	4T530FIMX15-M-03	23	1
F70338	4T530FIMX15-M-03	33	1
F70339	4T530FIMX15-M-03	24	1
F70345	4T530FIMX15-M-03	30	1

F70354	4T530FIMX15-M-03	25	1
--------	------------------	----	---