

TM RACING
USES AND
RACOMMENDS



TM Racing SpA - Via Fano, 6
61122 Pesaro - ITALY
Phone: +39 0721 25113

Catalogo Ricambi
Spare Parts Catalog

MOTORE
ENGINE
MY2020

2T
144
MX



INFORMAZIONI GENERALI

Il presente catalogo serve per richiedere con esattezza le parti di ricambio.

Nelle ordinazioni indicare:

1) Il numero di matricola del Telaio che è stampigliato sul lato destro del canotto di sterzo. Nei modelli EN, SMR, SMR il numero di matricola è riportato anche su una targhetta posta sul lato sinistro (Vedi foto).

2) il numero di serie del Motore. E' posto sulla sinistra del motore tra la leva cambio e i coperchio accensione (Vedi foto).

3) Il codice dei particolari seguito dalla descrizione.

4) Il colore per i pezzi verniciati o comunque colorati.

Le indicazioni destra e sinistra si riferiscono ai lati del veicolo rispetto al senso di marcia.

Foto e disegni sono solo a scopo informativo e potrebbero non corrispondere esattamente alle caratteristiche dei prodotti.

GENERAL INFORMATION

The present spare parts catalogue enables one to order exactly the right spare part.

When ordering specify:

1) The frame serial number. It is embossed on the right side of the steering metal tube. In the EN, SMR and SMR models, the serial number is also stated on a plate positioned on the left hand side (See photo).

2) The engine serial numer. It is located on the left side of the engine between the gear lever and the ignition cover (See photo).

3) The part's code number followed but its description.

4) Indicate colour for painted or colored parts.

References to right and left apply to the vehicle in terms of its direction of movement.

Photos and drawings are for informational purposes only and may not exactly match the characteristics of the products.

NOTE – LEGENDA

MY

NOVITA' INTRODOTTA DIFFERENTE O NON PRESENTE NEL MODELLO DELL'ANNO PRECEDENTE

PART DIFFERENT OR NOT PRESENT IN THE REVIOUS YEAR MODEL

5M

MOTORE CON CAMBIO A 5 MARCE
ENGINE WITH 5 GEARS SPEED

6M

MOTORE CON CAMBIO A 6 MARCE
ENGINE WITH 6 GEARS SPEED

KS

MOTORE CON SOLO KICK STARTER
ENGINE WITH KICK STARTER ONLY

ES

MOTORE CON AVVIAMENTO ELETTRICO
ENGINE WITH ELECTRIC STARTER

X

RICAMBIO NON DISPONIBILE ALLA VENDITA
PART CAN NOT BE SOLD SEPARATELY

Le illustrazioni riportate in questo manuale sono fornite solo come riferimento e possono variare dal prodotto effettivo,

Dati indicativi soggetti a modifiche senza impegno di preavviso.

The illustrations in this manual are for reference only and may vary from the actual product.

All data are subject to modification without prior notice.

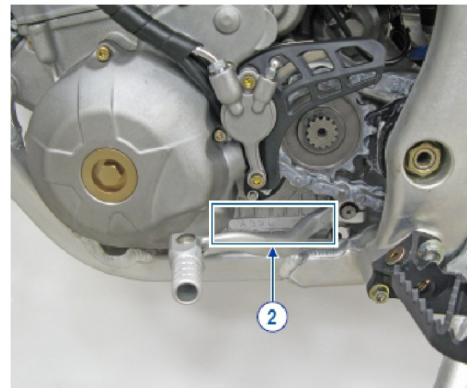
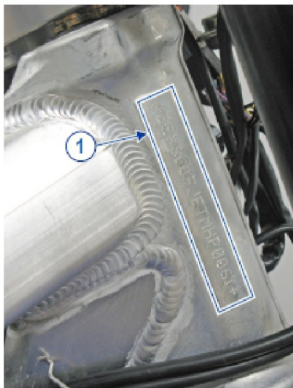



2T144MX20-M
MOTORE - ENGINE

SOMMARIO
TABLE OF CONTENTS

CILINDRO - CYLINDER.....	4
MOTORINO VALVOLA - ELECTRIC VALVE SYSTEM.....	7
ALBERO MOTORE - PISTONE - CRANKSHAFT - PISTON.....	9
ACCENSIONE - IGNITION.....	11
BASAMENTO - CRANKCASE.....	13
FORCHETTE CAMBIO - GEAR FORKS.....	15
FRIZIONE - CLUTCH.....	18
COPERCHI FRIZIONE - CLUTCH CASE.....	21
CAMBIO MX - GEARBOX MX.....	23



2T144MX20-M
MOTORE - ENGINE

CILINDRO
CYLINDER

1

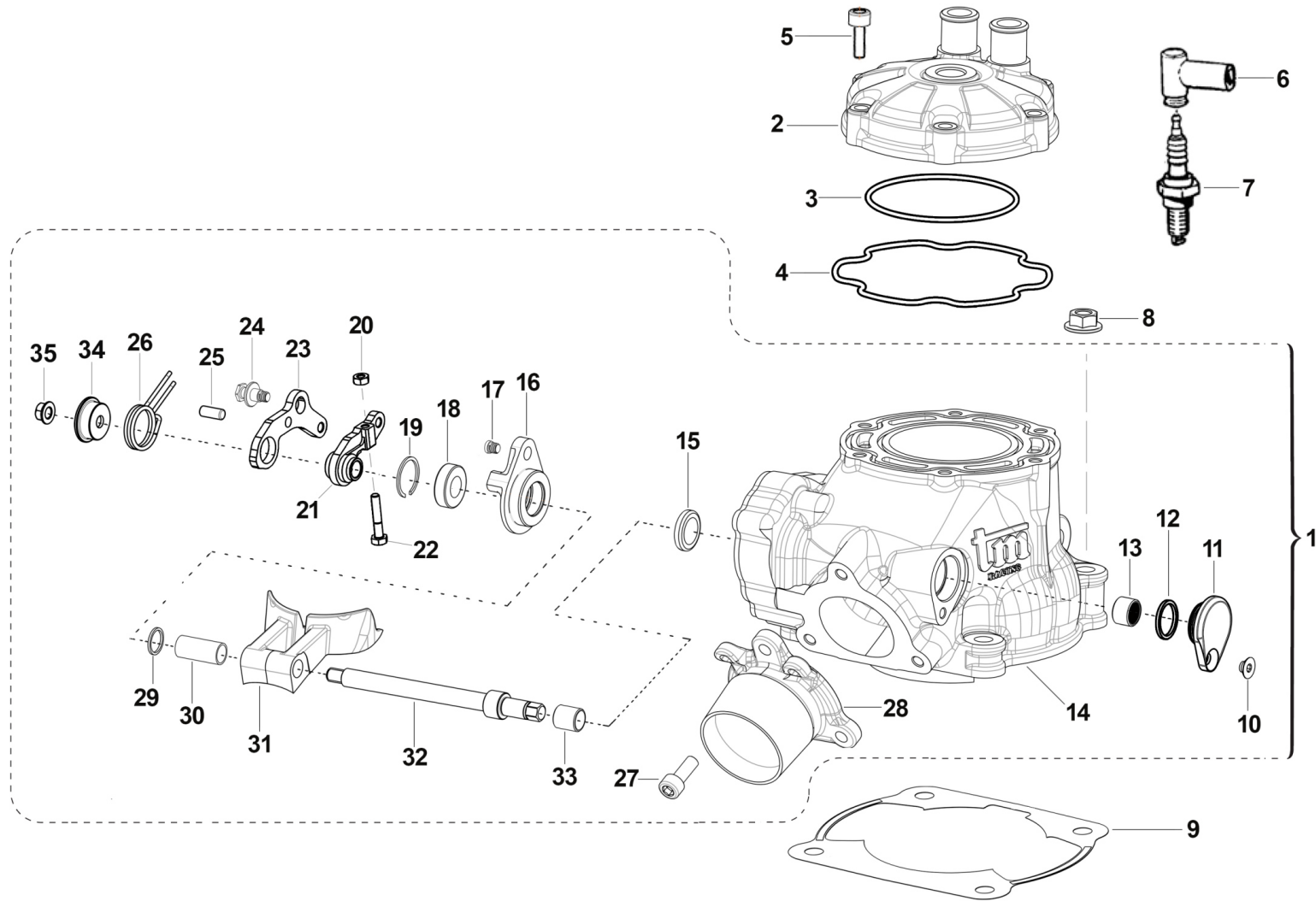



2T144MX20-M
MOTORE - ENGINE

CILINDRO
CYLINDER

1

Pos.	Codice	Q.tà	Note	Descrizione	Description
1	01134	1	MY20	CILINDRO 144 2T MX/EN MY20 CPL (CARB)	CYLINDER 144 2S EN/MX MY20 ASSY
2	02025	1		TESTA 144 CR/E EV M. 2013	HEAD 144cc MX/END M.13->
3	12003	1		O RING TESTA 125 90/06KVK8-910	O-RING, HEAD 125 90/06 KV8910
4	12021	1		O RING PREFORMATO CIL.125/12->	O-RING, HEAD 125EV M. 2012
5	49358	6		VITE TE F/R 6X30 Ch.8	BOLT 6X30 T.8
6	21017	1		PIPETTA CANDELA NGK LB05EMH	CAP, NGK SPARK PLUG LB05EMH
7	06011	1		CANDELA NGK BR9EG	SPARK PLUG, NGK BR9EG
8	49640	4		DADO M 8 FLANGIATO CHIAVE 12	NUT 8mm, FLANGE
9	05530	1		GUARN. B/CIL 125 M.2012 0,10	GASKET, CYL 125EV M.12/-> 0,10
9	05531	1		GUARN. B/CIL 125 M.2012 0,15	GASKET, CYL 125EV M.12/-> 0,15
9	05532	1		GUARN. B/CIL 125 M.2012 0,20	GASKET, CYL 125EV M.12/-> 0,20
9	05533	1		GUARN. B/CIL 125 M.2012 0,30	GASKET, CYL 125EV M.12/-> 0,30
9	05534	1		GUARN. B/CIL 125 M.2012 0,40	GASKET, CYL 125EV M.12/-> 0,40
9	05535	1		GUARN. B/CIL 125 M.2012 0,50	GASKET, CYL 125EV M.12/-> 0,50
10	49399	1		VITE TSEI 5X12	BOLT TSEI 5x12
11	30217	1		TAPPO SX ALB.COM.VALV.PAL.125	SIDE COVER
12	F12308	1		O RING 17,5 - 1,5	O-RING 17,5 - 1,5
13	19060	1		ASTUCCIO A RULLI HK 1212	NEEDLE CAGE HK 1212
14	01133	1	MY20	CILINDRO 144 2T MX/EN MY20 NUDO (CARB)	CYLINDER 144 2S MY20
15	04115	1		PARAOLIO G 12X18X3	OIL SEAL 12x18x3
16	26258	1	MY20	FLANGIA PORTACUSC.ALB.VALV.250/300 IE	FLANGE, BEARING HOLDER
17	49355	1		VITE TE F/R 6X16 Ch.8	BOLT 6X16 T.8
18	03156	1		CUSCINETTO V.SC.C.12 698LLU/5K	BUSH, EXHAUST VALVE 698LLU
19	49220	1		SEEGER INT.19	SEEGER I 19
20	49630	1	MY20	DADO M 4 (BASSO)	NUT 4mm, LOW
21	28108	1	MY20	LEVA INTERNA COMANDO VALVOLE EES-2 125/144 2020	LEVER, INTERNAL, VALVE
22	49874	1	MY20	VITE TE 4X16	BOLT TE 4X16
23	28263	1	MY20	LEVA ESTERNA COMANDO VALVOLE EES-2	LEVER, EXTERNAL, VALVE



2T144MX20-M
MOTORE - ENGINE

CILINDRO
CYLINDER

1

Pos.	Codice	Q.tà	Note	Descrizione	Description
24	26168	1	MY20	PERNO MOLLA EES-2 16066	PIN, SPRING
25	F19536	1	MY20	RULLO D. 5 X 12 M6 DIN 6325	PIN 5X12
26	16066	1	MY20	MOLLA EES-2	SPRING
27	49355	3		VITE TE F/R 6X16 Ch.8	BOLT 6X16 T.8
28	13081	1		COLLETTORE SCA. 125 12/-> 3F	MANIFOLD EXHAUST 125cc 12->
29	26130.12	1		SPESS. REG. CIL.125 2012 1.2	SPACER CYL. 125 ->12 1.2
29	26130.13	1		SPESS. REG. CIL.125 2012 1.3	SPACER CYL. 125 ->12 1.3
29	26130.14	1		SPESS. REG. CIL.125 2012 1.4	SPACER CYL. 125 ->12 1.4
29	26130.15	1		SPESS. REG. CIL.125 2012 1.5	SPACER CYL. 125 ->12 1.5
29	26130.16	1		SPESS. REG. CIL.125 2012 1.6	SPACER CYL. 125 ->12 1.6
29	26130.17	1		SPESS. REG. CIL.125 2012 1.7	SPACER CYL. 125 ->12 1.7
29	26130.18	1		SPESS. REG. CIL.125 2012 1.8	SPACER CYL. 125 ->12 1.8
29	26130.19	1		SPESS. REG. CIL.125 2012 1.9	SPACER CYL. 125 ->12 1.9
30	26147	1	MY20	BOCCOLA DIST. CIL.250/300 2015	BUSH
31	22147	1		VALVOLE SCARICO 144 EV M2013	
32	28059	1		ALBERO COMANDO PALETTE 125	SHAFT, BOOSTER 125
33	19061	1		BOCCOLA IR 8X12X12.5	BUSH, IR 1X12X12,5
34	26167	1	MY20	PIATTELLO GUIDA MOLLA EES-2 16066	COLLAR, SPRING
35	49676	1	MY20	DADO M 6X1 FLANG. AUTOBL.ACC.	NUT, FLANGED M6 X 1 S.B.



2T144MX20-M
MOTORE - ENGINE

MOTORINO VALVOLA
ELECTRIC VALVE SYSTEM

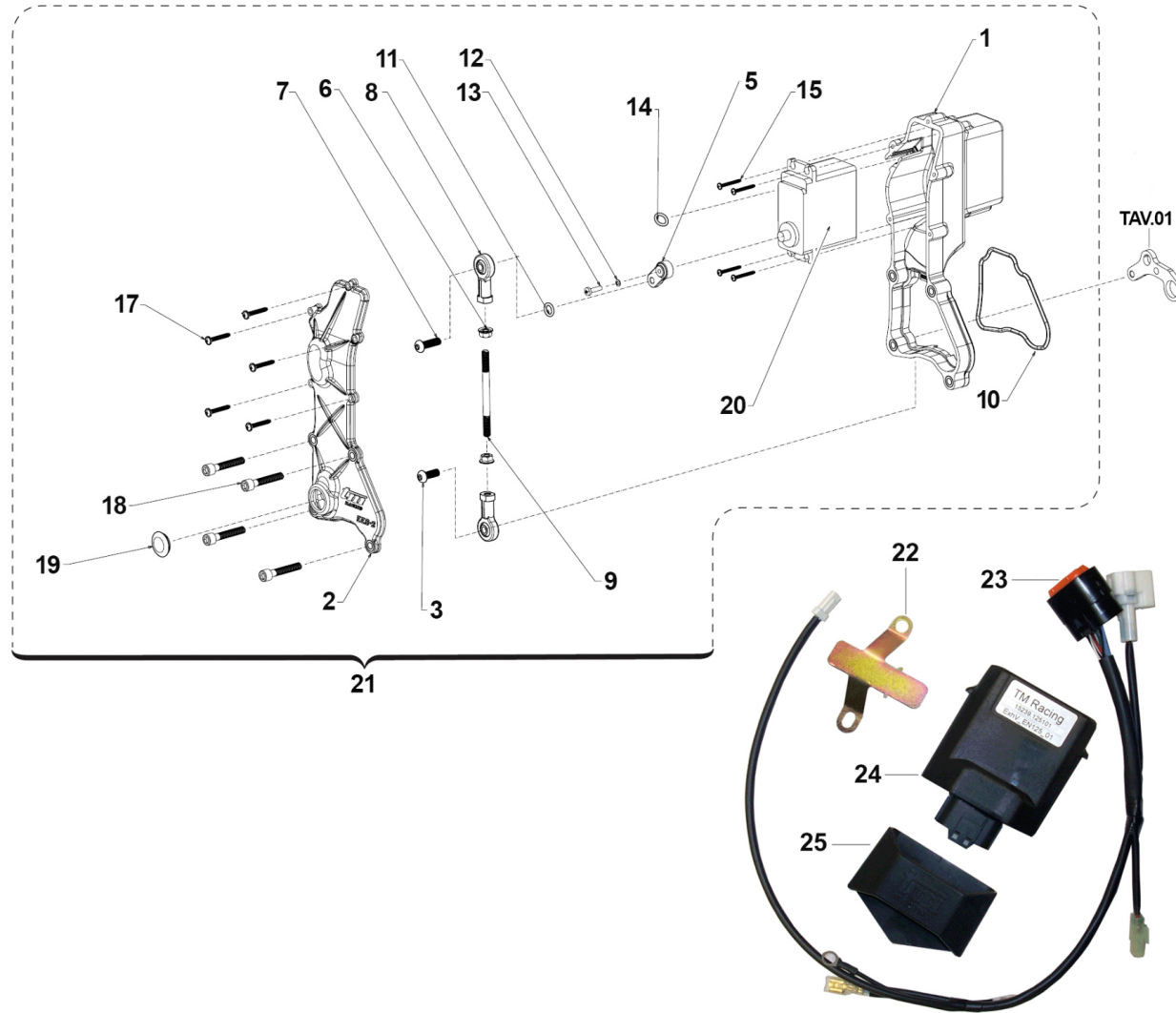



2T144MX20-M
MOTORE - ENGINE

MOTORINO VALVOLA
ELECTRIC VALVE SYSTEM

2

Pos.	Codice	Q.tà	Note	Descrizione	Description
1	30291	1	MY20	CARTER EES-2 125/144 2T FI	CASE, PLASTIC, ENGINE VALVE
2	30392	1	MY20	COPERCHIO CARTER EES-2 125/144 2T FI	
3	49472	1	MY20	VITE TCEI 5X12	BOLT TCEI 5X12
5	28266.0	1	MY20	LEVA SERVOMOTORE EES-2 DENTATURA 0	LEVER
5	28266.1	1	MY20	LEVA SERVOMOTORE EES-2 DENTATURA 1	LEVER
6	49632	2	MY20	DADO M 5	NUT 5mm
7	49929	1	MY20	VITE TBCE 5X18	BOLT
8	72251	2	MY20	SNODO MECCANISCO VALVOLA EES-2 250/300	JOINT
9	28109	1	MY20	ASTINA COLLEGAMENTO UNIBALL EES-2 125/144 2020	ROD, UNIBALL 125/144 MY20
10	12042	1	MY20	O RING COP. VALVOLA EES-2	O-RING
11	F12301	1	MY20	O RING 106 4T PIOGGIA CAMBIO	O-RING, 106 GEAR F.S.
12	49700	1	MY20	RONDELLA 3 VALVOL.	WASHER
13	49304	1	MY20	VITE T.C. 3X12	BOLT
14	F12321	1	MY20	O RING BOCCOLA CENTR. CILINDRO	O-RING
15	49973	4	MY20	VITE STS-Plus KN6031 2.2X20 PLASTICA	BOLT
17	49919	5	MY20	VITE TCBL 3.0X 20 FL. X PLAST.	BOLT
18	49478	4	MY20	VITE TCEI 5 X 30	BOLT TCEI 5X30
19	21009	1	MY20	TAPPO GOMMA COPERCHIO VALV.SC.	RUBBER, COVER
20	22500	1	MY20	SERVOMOTORE VALV.SCARICO HITEC	EL. ENGINE EXHAUST VALVE HITEC
21	22502.20	1	MY20	SERVOMOTORE V/SC. CPL 125/144 MY20	EL. ENGINE EXHAUST, 125/144 MY20 ASSY
22	26219	1		PIASTRINO SUPP.CENTR.V.EES 125	PLATE, ECU TMEES 125/144
23	68191	1		CABLAGGIO VALV.EL.125/250MX/EN	WIRE. EXHA.VALVE T.S.250 MX/EN
24	15239.144200	1	MY20	CENTRALINA	CDI
25	F15562	1		SUPPORTO CENTRALINA KOKUSAN	HOLDER ECU KOKUSAN

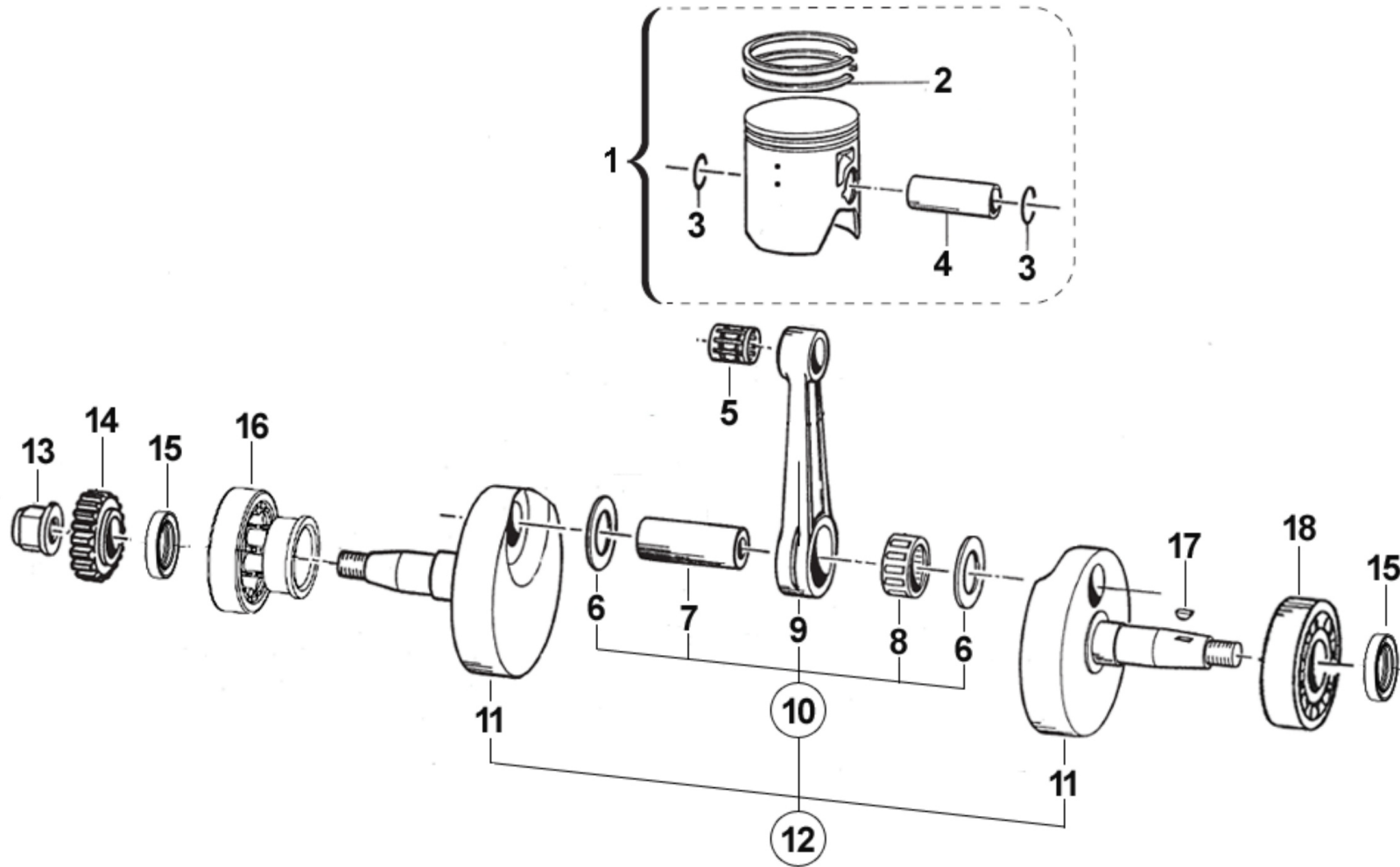



2T144MX20-M
MOTORE - ENGINE

ALBERO MOTORE - PISTONE
CRANKSHAFT - PISTON

3

Pos.	Codice	Q.tà	Note	Descrizione	Description
1	10023.94	1		PISTONE 55,94 2F 144cc CPL	PISTON 55,94 2R 144cc ASSY
1	10023.95	1		PISTONE 55,95 2F 144cc CPL	
2	11065	2		SEGMENTO 56 X 1 144cc	RING 56X1 144cc
3	09004.1	2		ANELLINO SPINOTTO PIST.125/144	CLIP, PISTON PIN 125 / 144
4	09008	1		SPINOTTO PISTONE 125 15X41F10	PIN, PISTON 125, 15x41 F10
5	19034	1		GABBIA SPINOTTO 15X19X17,3	TOP END B. 15X19X17,3
6	18248	2		RONDELLA ARGENTATA D.24	WASHER, SILVER ID.24
7	18079	1		ASSE ACCOPP.D.24 mm f.8 c/tapp	CRANKPIN 24 X 50,4 125/144
8	17074	1		GABBIA ARGENTATA D.24X31X16 P.	SILVER CAGE 24x31x16
9	18144	1		BIELLA FORGIATA NUDA 144 cc	CONNECTING ROD 144cc
10	18145	1		BIELLA 144cc CPL	CONROD KIT, 144cc ASSY
11	18177.13	1		COPPIA SEMIALBERI 144 EV 2013	CRANKSHAFT SIDES 144 EV13
12	18178.13	1		ALBERO MOTORE 144 EV 2013 CPL	CRANKSHAFT 144 ASSY EV M13->
13	49094	1		DADO TRASMISS.125 06 M14X1.25	NUT,CLUTCH CENT.14X1.25 125 06
14	40303	1		PIGNONE COPPIA PRIMARIA Z19 CR	PRIMARY DRIVE GEAR 19T MX
14	50030	1		ESTRATTORE PIGNONE COPPIA	PRIMARY GEAR PULLEY
15	04035	2		PARAOILIO 20x30x7 PTFE	OIL SEAL 20 x 30 x 7 PTFE
16	03026	1		CUSCINETTO ALBERO MOTORE NJ206	BUSH, NJ206 CRANKSHAFT
17	49010	1		CHIAVETTA VOLANO 13x5x3	WOODRUFF KEY
18	03255	1		CUSCINETTO ALB.MOTORE 125 M.13	BUSH, CRANKSHAFT 125 M.13

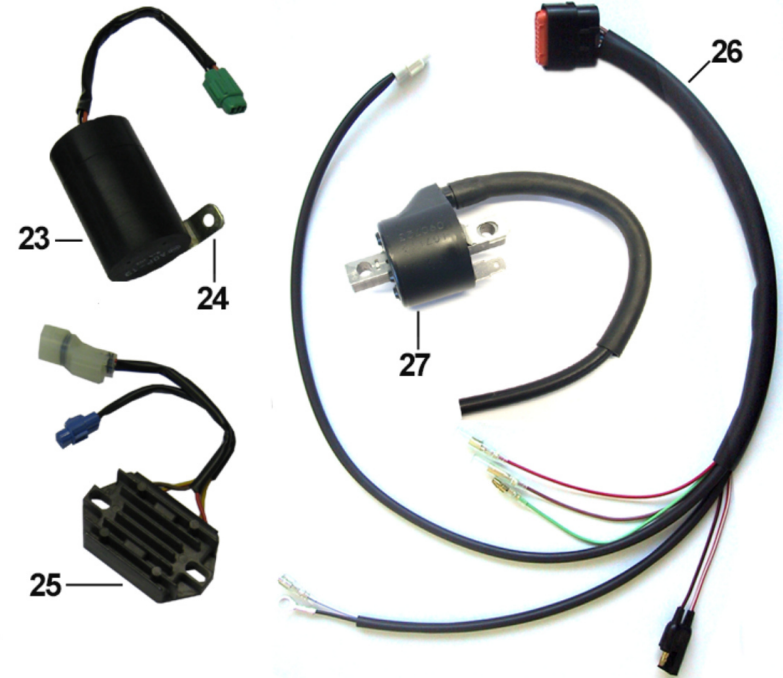
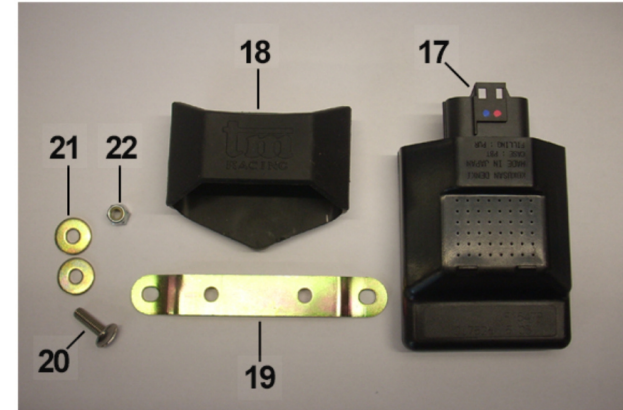
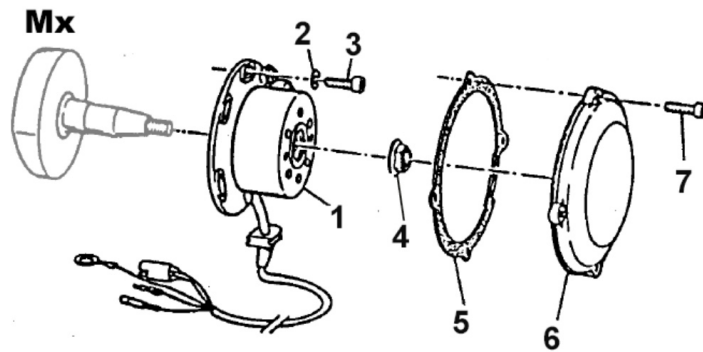



2T144MX20-M
MOTORE - ENGINE

ACCENSIONE
IGNITION

4

Pos.	Codice	Q.tà	Note	Descrizione	Description
1	15230	1		GENERATORE KOK END 11 MX/E 12	GENERATOR KOK END 11 MX/E 12->
1	50051	1		ESTRATTORE ACCEN.KOK.2T 27X1 S	FLYWHEEL PULLER KOKUSAN 2S
2	49603	2		RONDELLA 6,4 X 12 X 1,5	WASHER 6x12
3	49484	2		VITE TCEI 6X20	BOLT TCEI 6X20
4	49056	1		DADO ACCENS 100/TAG/KZ 125MX/E	NUT, IGNITION 100cc
5	05516	1		GUARN. COP.ACC. 80/125 KOKUSAN	GASKET, KOK.IGNIT.COV. 80/125
6	30211	1		COP. ACC. MX 125/144 06/11 E11	IGNICT.COVER MX 80/125 2006 KO
7	49477	4		VITE TCEI 5X25 UNI 5931	BOLT TCEI 5X25
17	15209.144001	1		CENTRALINA TMEES IG_144_01	ECU TMEES IG_144_01
18	F15562	1		SUPPORTO CENTRALINA KOKUSAN	HOLDER ECU KOKUSAN
19	F26537	1		PIASTR.FISS.SUP.ECU KOK.F15562	PLATE HOLDER UCU KOKUS. F15562
20	49377	2		VITE TB LARGA 5X16 COMBI	BOLT LARGE 5x16
21	49602	4		RONDELLA 5 x 15 x 1,2	WASHER 5x15
22	49633	2		DADO M 5 BASSO AUTOBLOCCANTE	NUT 5mm, LOW SELF-LOCKING
23	F15557	1		CONDENSATORE SHINDENGEN ADP19 NERO! CILINDRICO!	CAPACITOR SHINDENGEN ADP19
24	26119	1		PIASTRINO FISS. CONDENS. 2010	HOLDER, CONDENSER
25	15107	1		REGOLATORE 2T M. 2011 RX2136	REGULATOR 2S M. 2011 - RX2136
26	68136	1		CABLAGGIO ECU KOK 2T 11/->	ECU WIRES KOKUSAN T.S. M.11->
27	15206	1		BOBINA KOKUSAN PIC. 2T IG7112	COIL, KOKUSAN 2 STROKE IG7112



2T144MX20-M
MOTORE - ENGINE

BASAMENTO
CRANKCASE

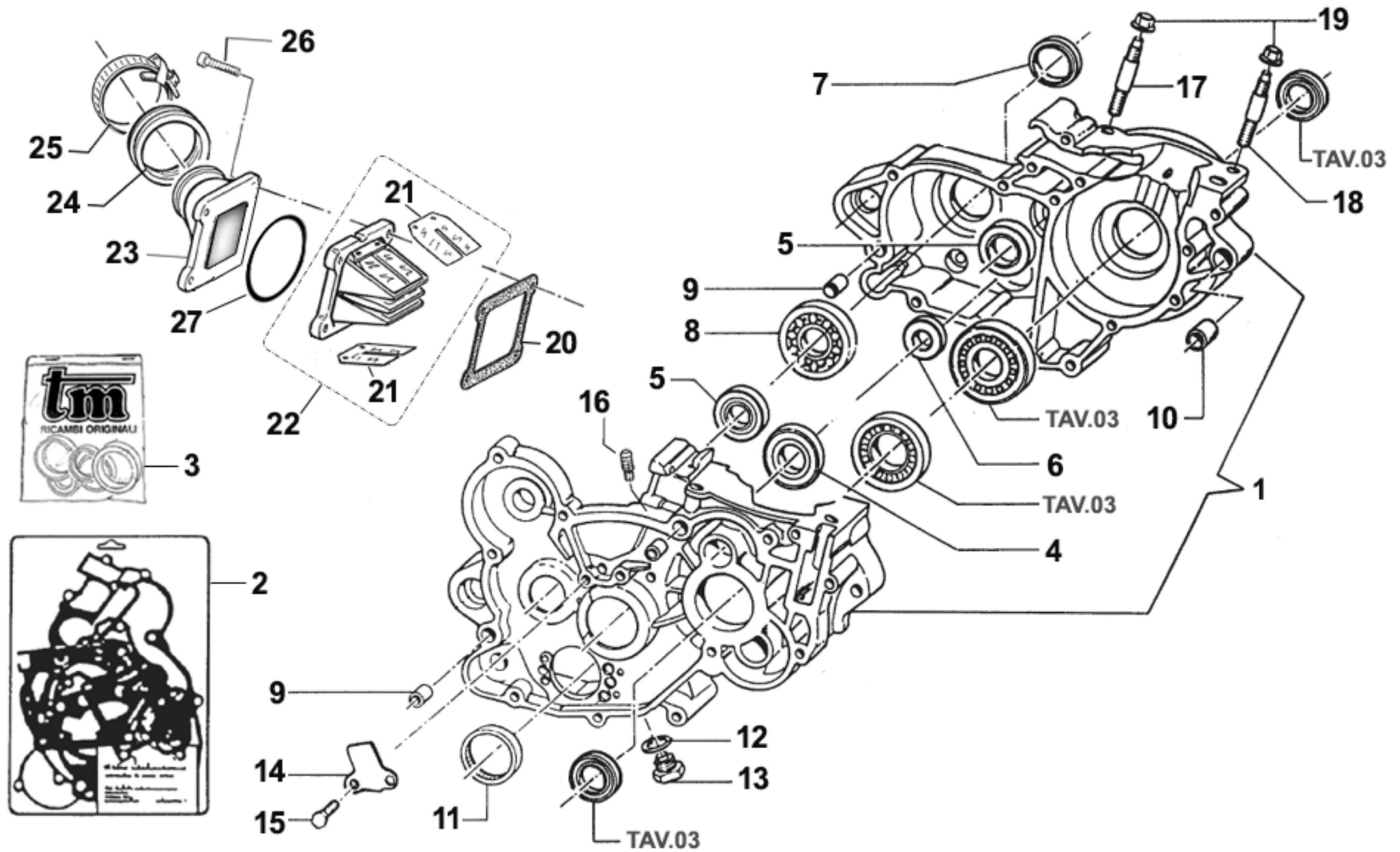



2T144MX20-M
MOTORE - ENGINE

BASAMENTO
CRANKCASE

Pos.	Codice	Q.tà	Note	Descrizione	Description
1	30177.19	1		BASAMENTO MOTORE 144 EV MY 2019	
2	05621	1		KIT GUARN. + OR 125 2012 V.EL	GASKETS + OR 125cc M.12->
3	04034.15	1		KIT PARAOLI 125 EV M.2015	OIL SEALS KIT 125cc EV M.15->
4	03011	1		CUSCINETTO ALBERO PRIM. 6204 Z C3	BUSH, GEAR MAINSHAFT
5	03009	2		CUSCINETTO 6202 Z C3 RIVETT.	BUSH, 6202 Z C3
6	03012	1		CUSCINETTO DESMODROMICO 6001 2RS	BUSH, 6001 2RS GEAR DRUM
7	04003	1		PARAOLIO PIGN.CATENA (26x37x7)	OIL SEAL 26 x 37 x 7
8	03010	1		CUSCINETTO 6204 C3 PIG.CATENA	BUSH, COUNTERSHAFT / SPROCKET
9	26044	3		GRANO CENTRAGGIO MOTOR.10X13,6	GRUB SCREW 10X13,6
10	26043	1		GRANO CARTER ANT. 14 X 14	GRUB SCREW 14X14
11	19041	1		ASTUCCIO A RULLI DHK 35/12	BUSH NEEDLE CAGE DHK 35/12
12	49103	1		RONDELLA 14X20X1,5 ALLUMINIO	WASHER, 14 X 20 X 1.5 ALUMINUM
13	49301	1		TAPPO OLIO C/CALAM. 2T	OIL PLUG WITH MAGNET
14	26023	1		PIASTRINO CONVOGLIATORE OLIO	PLATE, OIL
15	49440	2		VITE TE 6X14	BOLT TE 6X14
16	49009	1		RACCORDO SFIATO OLIO MX/E F.4	JOINT, OIL BREATHER
17	49161	2		PRIG. TESTA POST. 144CC M08	STUD
18	49020	2		PRIGIONIERO CIL.48 mm 80/125	STUD CYL.48mm 80/125cc
19	49640	4		DADO M 8 FLANGIATO CHIAVE 12	NUT 8mm, FLANGE
20	05277	1		GUARN. PACCO LAMELLE VFORCE 3	GASKET, REED BLOCK VFORCE 3
21	20074	1		LAMELLE V-FORCE3 125/144 07/->	REEDS, V-FORCE3 125/144 07/->
22	20061	1		PACCO LAM 125/144 VF3 M. 08/->	REEDS BOX VF3 125/144 M. 08/->
23	13086	1		COLLETTORE AI ASP. 125cc 2013	MANIFOLD, INTAKE, ALUMINIUM, 125
24	13009	1		MANICOTTO COLLETTORE ASP.97/14	MANIFOLD RUBBER,INTAKE M.97/14
25	51054	2		FASCETTA SM9 D.52	CLAMP SM9 D.52mm
26	49484	4		VITE TCEI 6X20	BOLT TCEI 6X20
27	12026	1		O RING CONVOGLIATORE 125 13086	O-RING INLET MANIFOLD 125 13086

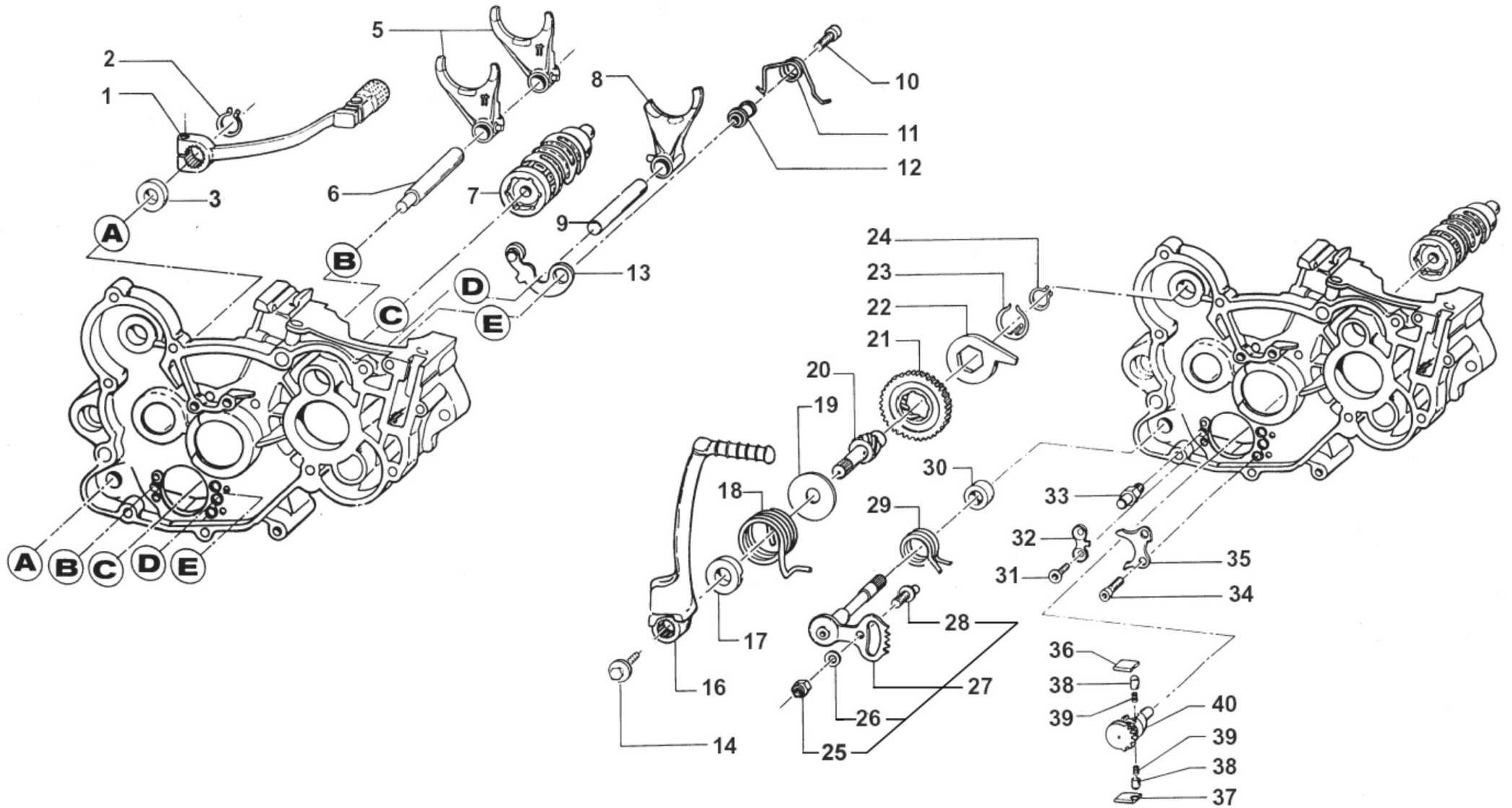



2T144MX20-M
MOTORE - ENGINE

FORCHETTE CAMBIO
GEAR FORKS

Pos.	Codice	Q.tà	Note	Descrizione	Description
1	43049	1		LEVA CAMBIO 250 / 300 2T E.S. 19	GEAR LEVER 250 / 300 T.STR. EL.ST. M.19->
2	49212	1		SEEGER E12 LEVA CAMBIO	CIRCLIP D.12 - EXTERNAL
3	04004	1		PARAOLIO POMPA H2O-LEVA CAMBIO	OIL SEAL 12 x 22 x 5
5	F33314	2		FORCHETTA A/S 125/250/300 CROM	SHIFT FORK SECONDARY 125/250CR
6	33256	1		PERNO FORCH.ALB.SEC. 250 / 125.99	AXEL, COUNTERSHAFT FORK 250cc
7	33004	1	MY20	ALBERO DESM.125 INTEGR. 6M CPL 125/144 6 M. CPL DI F26476	GEAR DRUM 125 6SP. 125/144 ASSY F26476
8	33016	1		FORCHETTA ALB.PRIM.125 PRT.CRM	SHIFT FORK MAINSHAFT 125 CROM.
9	33255	1		PERNO FORCH.ALB. PRIM.250 / 125.99	AXEL, MAINSHAFT FORK 250cc
10	49485	1		VITE TCEI 6X25 UNI 5931	BOLT TCEI 6x25
11	16252.12	1		MOLLA BLOCCAMARCE 125/250 2012	SPRING, STOP GEAR 125/250 M.12
12	26007	1		DISTANZIALE MOLLA BLOCCAMARCE	SPACER, STOP GEAR SPRING
13	26063.12	1		PIASTRINO BLOCCAMARCE 2012 CPL	PLATE STOP GEAR ASSY M.12->
14	49368	1		VITE TE F/R 6X10 LEVA M/M	BOLT 6X10 (Kich Starter)
16	43038	1		LEVA M/M 80/125 M. 99/->	LEVER, KICK STARTER 125 99/->
17	26005	1		DISTANZIALE MOLLA M/M	SPACER, KICK STARTER SPRING
18	16008	1		MOLLA M/M 80 / 125 / 144 cc	SPRING, KICK STARTER
19	48008	1		RONDELLA ALBERO MESSA IN MOTO	WASHER, KICK STARTER SHAFT
20	28051	1		ALBERO MESSA IN MOTO 125/144 96/18	SHAFT, KICK STARTER 125 96/05
21	40350	1		INGRANAGGIO SCORREVOLE M/M 125 / 144	SLIDING GEAR, KICK STARTER 125
22	26254	1		LEVA BATTUTA M/M 125/250 96/->	STOPPER, KICK STARTER
23	16006	1		MOLLA X INGRANAGGIO M/M	SPRING, KICKSTART SLIDING GEAR
24	49214	1		SEEGER E15 INGRANAGGIO M/M	CIRCLIP GEAR K.S. 15mm
25	49638	1		DADO M 6 ALTO AUTOBLOCCANTE	NUT 6mm, HIGHT SELF-LOCKING
26	49603	1		RONDELLA 6,4 X 12 X 1,5	WASHER 6x12
27	28100	1		ALBERO COMANDO ING. P.TACRIC.	SHAFT, GEARSHIFT
28	26050	1		BATTUTA ECCENTRICA	ADJUSTER SELECTOR SHAFT
29	16009	1		MOLLA RITORNO LEVA CAMBIO 32CR	SPRING, RETURN GEAR LEVER 3,2



2T144MX20-M
MOTORE - ENGINE

FORCHETTE CAMBIO
GEAR FORKS

6

Pos.	Codice	Q.tà	Note	Descrizione	Description
30	26006	1		DISTANZIALE MOLLA LEVA CAMBIO	SPACER, GEAR LEVER SPRING
31	49405	2		VITE TSEI 6X20 UMB.5933 10.9	BOLT TSEI 6x20 U.5933 10.9
32	26022	1		PIASTRINO FINE CORSA	PLATE END STROKE GEAR LEVER
33	26051	1		BATTUTA FISSA LEVA CAMBIO INT.	PLATE INT. END STROKE GEAR LEVER
34	49483	2		VITE TCEI 6X16	BOLT TCEI 6X16
35	26021	1		PIASTRINO RIENTRO CRICCHETTI	PLATE, RATCHET
36	26060	1		CRICCHETTO CAMBIO SUPERIORE	RATCHET UP, GEAR
37	26061	1		CRICCHETTO CAMBIO INFERIORE	RATCHET DOWN, GEAR
38	26062	2		PUNTALE PER CRICCHETTO CAMBIO	PIN, RATCHET GEAR
39	16012	2		MOLLA PER PUNTALE	SPRING, GEARBOX PIN
40	40310	1		INGRANAGGIO PORTACRICCHETTI	DRUM SHIFTER GEAR

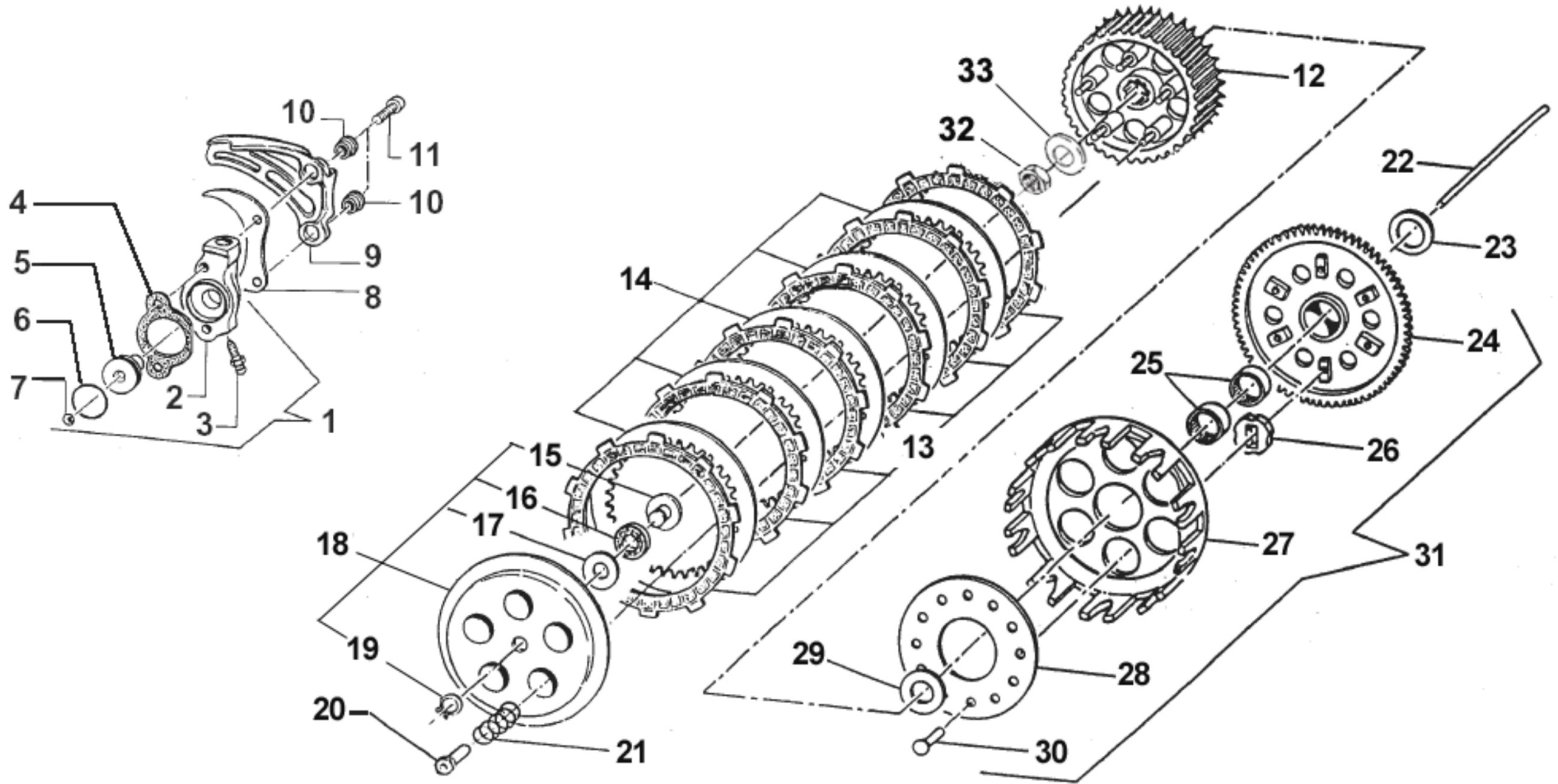



2T144MX20-M
MOTORE - ENGINE

FRIZIONE
CLUTCH

Pos.	Codice	Q.tà	Note	Descrizione	Description
1	30206	1		COP. FRIZ/IDR 85/125 95/-> CPL	OUTPUT H.CLUTCH CYLINDER CPL.
2	30205	1		COP. FRIZ/IDR 80/125 95/11 NUD	OUTPUT H.CLUTCH CYLINDER
3	35264	1		VITE SPURGO OLIO FRIZ.IDR.6X1	SCREW AIR BLED HYDRAUL.CLUTCH
4	05509	1		GUARN. POMPA FRIZ.IDR. 80/125	GASKET, HYDRAULIC CLUTCH80/125
5	35125	1		PISTONE POMPA FRIZ. 125 95/->	PISTON, CLUTCH PUMP 125 95/04
6	12259	1		O RING PISTONE FR.125/250VERDE	O-RING, CLUTCH PISTON 125/250
7	19052	1		SFERA 8 X FRIZIONE 250	BALL, IDR. CLUTCH PUMP
8	40022	1		PROTEZIONE ERGAL PIGNONE CAT.	PROTECTION, GEAR CHAIN ERGAL
9	40029	1		PROTEZIONE PIGNONE 09/-> PLAST	PROTECTION FRONT SPROCKET09/13
10	26212	2		BOCCOLA PROT. PIGNONE 125 F.6	COLLAR, SPROCKET 125cc H.6
11	49486	2		VITE TCEI 6X30	BOLT TCEI 6X30
12	25099.14	1		TAMBURELLO FRIZIONE 125 2014	CLUTCH CENTRE 125cc M.14->
12	50124	1		CHIAVE FRIZ. 85/125 + KART CPL	CLUTCH TOOL 85/125cc + KART
13	35012	8		DISCO FRIZ. GUARN.CR/E M.93->	CLUTCH PLATE, FIBER MX/E 93/->
14	35019	7		DISCO FRIZ. ACC. 1mm 99/05	CLUTCH PLATE, STEEL 1mm 99/05
15	26001	1		REGGISPINTA FRIZIONE	CLUTCH THRUST
16	19020	1		GABBIA A RULLI RAD. AXK 1024	NEEDLE CAGE AXK 1024, RADIAL
17	19021	1		RONDELLA X GABBIA RULLI AS1024	WASHER, NEEDLE CAGE AS 1024
18	35025	1		PIATTO SPING.FRIZ 125/KART CPL	PLATE, CLUTCH PRESSURE ASSY
19	49211	1		SEEGER E09 ANELLO PIATT.REG.	CIRCLIP D.8,4 - EXTERNAL
20	49057	5		DADO FRIZIONE ERGAL KZ10	NUT, CLUTCH KZ10 ERGAL
21	16020	5		MOLLA FRIZIONE 125 C/E 03/08BA	SPRING, CLUTCH 125 MX/E 03/->
22	35043	1		ASTINA FRIZ. IDR. 125 M.99/10	ROD, HYDR.CLUTCH 125 M. 99/04
23	48003	1		SPESSORE COP.PRIM.30X20X2	SPACER 30X20X2 PRIMARY GEAR
24	40402	1		COPPIA PRIM. 125 Z63	PRIMARY GEAR 63T, 125cc
25	19013	2		GABBIA A RULLI K 20X24X12	NEEDLE CAGE 20 X 24 X 12
26	21005	6		GOMMINO PARASTRAPPI FRIZIONE	RUBBER, CLUTCH BASKET
27	25000	1		CAMPANA FRIZ.125 M.91/96 99/13	CLUTCH BASKET 125 91/96 99/05



2T144MX20-M
MOTORE - ENGINE

FRIZIONE
CLUTCH

7

Pos.	Codice	Q.tà	Note	Descrizione	Description
28	35026	1		DISCO BATTUTA GOMM. FRIZ.KZ10B	DISC STOP RUBBERS CLUTCH KZ10B
29	48002	1		SPESSORE COP.PRIM.30X18X3	SPACER 30x18x3
30	49727	6		VITE PARASTRAPPI K9 M7X1X12.5	SCREW, M7X1X12,5 K9 ENGINE
31	40409	1		COPPIA PRIM. 125 Z63 CPL 99/-> 93/96	PRIM.GEAR 63T,125 Comp. 99/04
32	49052	1		DADO TAMBURELLO FRIZIONE	NUT, CLUTCH CENTER
33	49127	1		MOLLA A TAZZA DIN 2093 28X14,2X1,25	WASHER 28X14,2X1,25

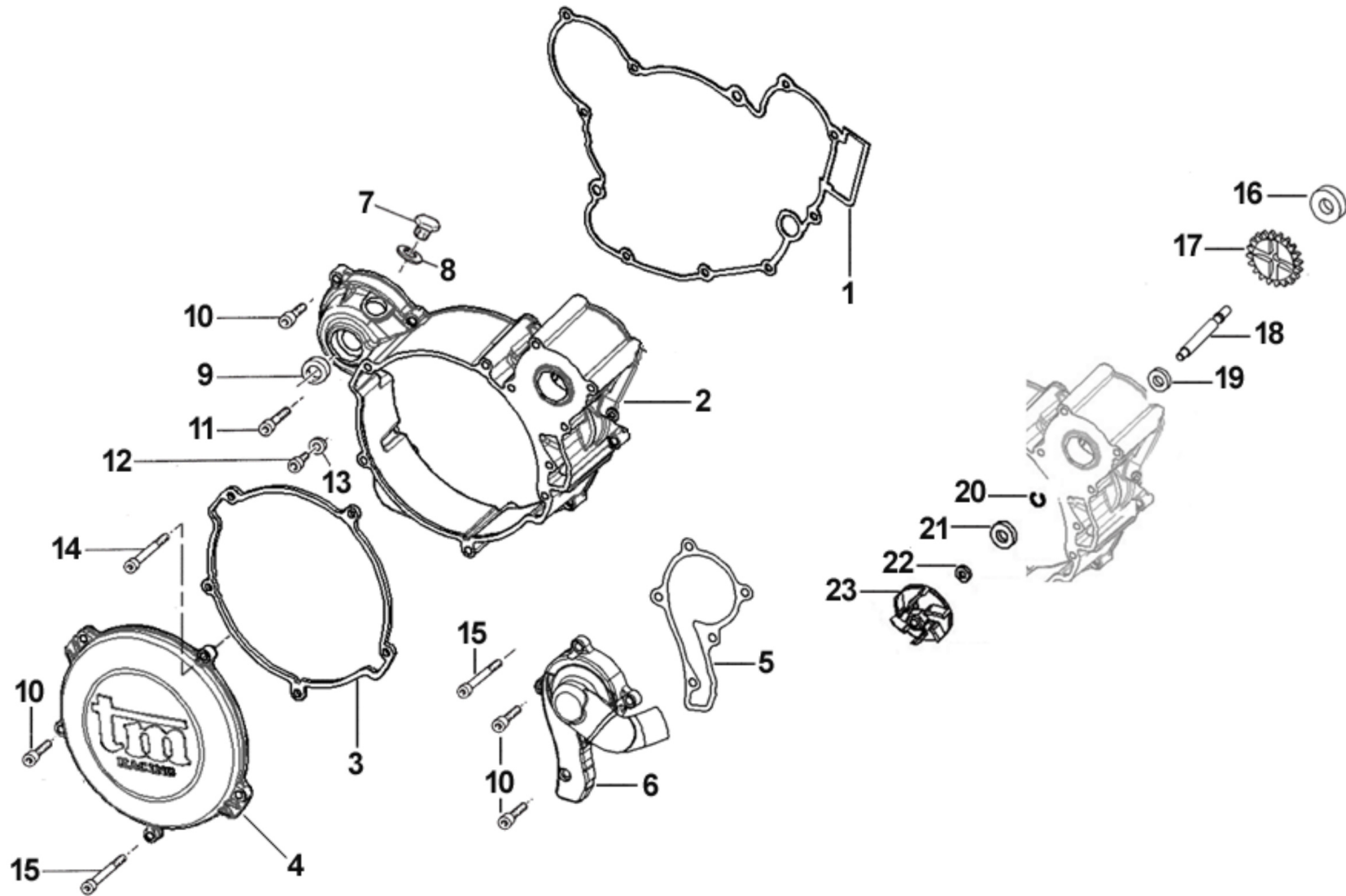



2T144MX20-M
MOTORE - ENGINE

COPERCHI FRIZIONE
CLUTCH CASE

Pos.	Codice	Q.tà	Note	Descrizione	Description
1	05527	1		GUARN. COP.FRIZ. INT.125 06/->	GASKET, CLUTCH CASE 125 06/->
2	30174	1		CARTER FRIZIONE 125 M.12/->	CLUTCH COVER 125 M.12->
3	05526	1		GUARN. COP.FRIZ. EST.125 06/->	GASKET, EXT.CLUTCH COVER 125/6
4	30187	1		COPERCHIETTO FRIZ. 125 M.2006	COVER, CLUTCH, EXT. 125 06/->
5	05528	1		GUARN. POMPA ACQUA 125 2006	GASKET WATER PUMP 125cc 2006
6	30194.06	1		COPERCHIO POMPA H2O CR/E 06/->	WATER PUMP COVER MX/E M.2006
7	49300	1		TAPPO CARICO OLIO	OIL PLUG, FILL
8	49103	1		RONDELLA 14X20X1,5 ALLUMINIO	WASHER, 14 X 20 X 1.5 ALUMINUM
9	04005	1		PARAOLIO ALBERINO M/M 15x24x7	OIL SEAL 15 x 24 x 7
10	49476	12		VITE TCEI 5X20 UNI 5931	BOLT TCEI 5X20
11	49477	1		VITE TCEI 5X25 UNI 5931	BOLT TCEI 5X25
12	49480	1		VITE TCEI 6X10	BOLT TCEI 6X10
13	49104	1		RONDELLA 6 x 10 x 1.5 ALLUMINIO	WASHER 6 x 10 x 1.5 ALUMINUM
14	49594	1		VITE TCEI 5X85	SCREW TCEI 5X85
15	49595	3		VITE TCEI 5X80	BOLT TCEI 5X80
16	03025	1		CUSCINETTO 626 C3 POMPA H2O 06	BUSH, WATER PUMP 626 C3
17	40071	1		INGR COMANDO POMPA H2O 125 '12	GEAR, WATERPUMP 125 M.12/->
18	28062	1		ALBERINO POMPA ACQUA 125 2012	SHAFT, WATERPUMP 125 M.12/->
19	03014	1		CUSCINETTO 608 ZC3 POMPA SCHER	BUSH, WATER PUMP 608 Z C3
20	49215	1		SEEGER POMPA ACQUA 22	CIRCLIP D.22 WATER PUMP
21	04017	1		PARAOLIO CENTRIFUGA 06 +MF1TAG	OIL SEAL 8 X 22 X 7 TC
22	49689	1		RONDELLA 6 X 12 SP. 1.2	WASHER 6x12 sp. 1,2
23	28009	1		GIRANTE POMPA ACQUA 2006/08	IMPELLER, WATER PUMP M.06/->

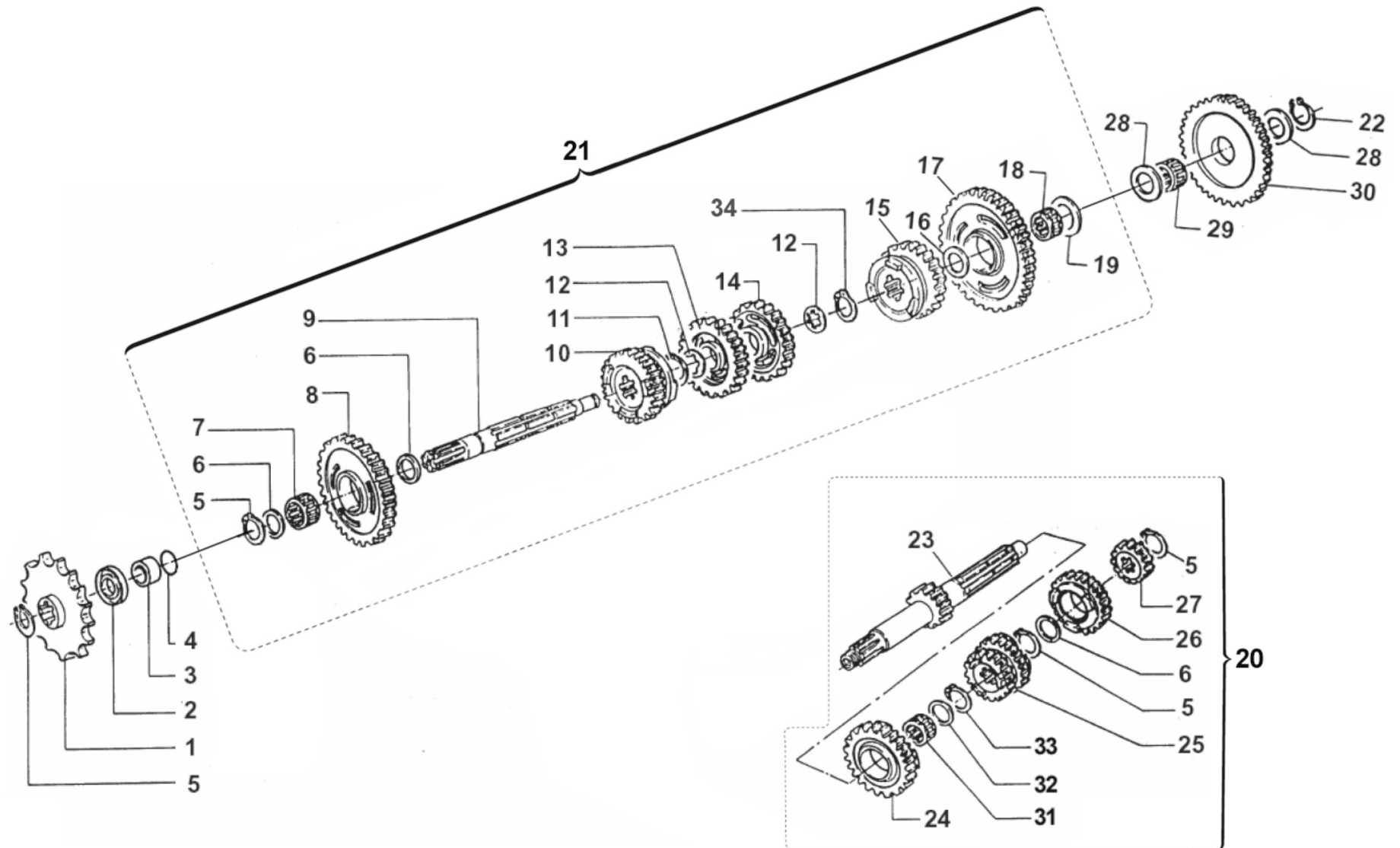



2T144MX20-M
MOTORE - ENGINE

CAMBIO MX
GEARBOX MX

Pos.	Codice	Q.tà	Note	Descrizione	Description
1	40024	1		PIGNONE CAT. Z 11 BR12 M.00/->	SPROCKET 11T, DRIVE M.00/10
1	40025	1		PIGNONE CAT. Z 12 BR12 M.00/->	SPROCKET 12T, DRIVE 125 00/->
1	40026	1		PIGNONE CAT. Z 13 BR12 M.00/->	SPROCKET 13T, DRIVE 125 00/->
2	04003	1		PARAOLIO PIGN.CATENA (26x37x7)	OIL SEAL 26 x 37 x 7
3	26002.1	1		DISTANZIALE PIGNONE (MOTO)	SPACER, MOTORCYCLE GEAR
4	12019	1		O RING PIGNONE CATENA	O-RING, DRIVE GEAR 2075
5	49216	4		SEEGER E20 PIGN.-CAMBIO-COPPIA	CIRCLIP D.20 - EXTERNAL
6	48013	3		RASAMENTO A/S 27X20X0,7	SPACER, 27x20x0,7
7	19012	1		GABBIA A RULLI K 20X24X10	BUSH NEEDLE CAGE 20 X 24 X 10
8	40708	1		INGR A.S. 2a Z 29 CR/E 90	GEAR, 2TH (29T) COUNTERSH.CR/E
9	40462	1		ALBERO SECONDARIO SCAN. 12	COUNTERSHAFT BR 12
10	40522	1	MY20	INGR A.S. 6a Z 24 END	GEAR, 6TH (24T) COUNTERSH.END.
11	49217	1		SEEGER E22 ANELLO ALB/S	CIRCLIP D.22 - COUNTERSHAFT
12	48011	2		RASAMENTO DENT.A/S 27X22X0,75	SPACER, 27x22x0,75
13	40710	1		INGR A.S. 4a Z 25 CR/E 90	GEAR, 4TH(25T)COUNTERSH.MX/E90
14	40709	1		INGR A.S. 3a Z 27 CR/E 90	GEAR, 3RD(27T)COUNTERSH.MX/E90
15	40510	1		INGR A.S. 5a Z 24 CR/E 90	GEAR, 5TH (24T) COUNTERSHAFT
16	48012	1		RASAMENTO A/S M/M SPESS.0,5	SPACER, 26x17x0,5
17	40470	1		INGRANAGGIO A.S. 1a Z 31 MX	GEAR 1St M X (31T) COUNTERSHAFT
18	19011	1		GABBIA A RULLI K 17X21X10	BUSH CAGE 17 X 21 X 10
19	48010	1		RASAMENTO ALB/S.28X15X0,5 INGI	SPACER, 28x15x0,5
20	40045	1	MY20	ALBERO PRIMARIO CPL 144 MX 6M	
21	40046	1	MY20	ALBERO SECONDARIO CPL 144 MX 6M	
22	49214	1		SEEGER E15 INGRANAGGIO M/M	CIRCLIP GEAR K.S. 15mm
23	40713	1		ALBERO PRIMARIO Z 14 MX RINF.	MAINSHAFT MX 14T
24	40440	1		INGR. A.P. 5a Z 22 K9B/C 10 R1 CR/E90	GEAR, 5TH (22T) MAINSHAFT
25	40702	1		INGR A.P. 3/4a Z 18/20 CR/E 90	GEAR, 3/4TH(18/20T)MAINSH.MX/E
26	40452	1	MY20	INGR A.P. 6a Z 27 END	GEAR, 6TH (27T) MAINSHAFT END.



2T144MX20-M
MOTORE - ENGINE

CAMBIO MX
GEARBOX MX

9

Pos.	Codice	Q.tà	Note	Descrizione	Description
27	40701	1		INGR A.P. 2a Z 16 CR/E 90	GEAR, 2ND (16T) MAINSH.MX/E 90
28	48004	2		SPESSORE INGRANAGGIO M/M	SPACER, K.STARTER GEAR
29	19010	1		GABBIA A RULLI K 15X19X10	BUSH NEEDLE CAGE 15 X 19 X 10
30	40351	1		INGRANAGGIO LIBERO M/M 125 / 144	GEAR, KICK STARTER 125
31	19071	1		GABBIA A 20X24X10 IN DUE META'	NEEDLE CAGE 20X24X10 TWO PIEC.
32	48041	1		RASAMENTO A/P 27.5X21X1 KZ10B	SPACER, MAINSHAFT 27,5X21X1 KZ
33	49222	1		SEEGER E 21 mm	CIRCLIP D.21 - EXTERNAL
34	49217.1	1		SEEGER RETTIFICATO PER 40510	SEEGER RING FOR CODE 40510