

TM RACING
USES AND
RACOMMENDS



TM Racing SpA - Via Fano, 6
61122 Pesaro - ITALY
Phone: +39 0721 25113

Catalogo Ricambi
Spare Parts Catalog

MOTORE
ENGINE
MY2020

2T
300 Fi
EN



INFORMAZIONI GENERALI

Il presente catalogo serve per richiedere con esattezza le parti di ricambio.

Nelle ordinazioni indicare:

1) Il numero di matricola del Telaio che è stampigliato sul lato destro del canotto di sterzo. Nei modelli EN, SMR, SMR il numero di matricola è riportato anche su una targhetta posta sul lato sinistro (Vedi foto).

2) il numero di serie del Motore. E' posto sulla sinistra del motore tra la leva cambio e i coperchio accensione (Vedi foto).

3) Il codice dei particolari seguito dalla descrizione.

4) Il colore per i pezzi verniciati o comunque colorati.

Le indicazioni destra e sinistra si riferiscono ai lati del veicolo rispetto al senso di marcia.

Foto e disegni sono solo a scopo informativo e potrebbero non corrispondere esattamente alle caratteristiche dei prodotti.

GENERAL INFORMATION

The present spare parts catalogue enables one to order exactly the right spare part.

When ordering specify:

1) The frame serial number. It is embossed on the right side of the steering metal tube. In the EN, SMR and SMR models, the serial number is also stated on a plate positioned on the left hand side (See photo).

2) The engine serial number. It is located on the left side of the engine between the gear lever and the ignition cover (See photo).

3) The part's code number followed but its description.

4) Indicate colour for painted or colored parts.

References to right and left apply to the vehicle in terms of its direction of movement.

Photos and drawings are for informational purposes only and may not exactly match the characteristics of the products.

NOTE – LEGENDA

MY

NOVITA' INTRODOTTA DIFFERENTE O NON PRESENTE NEL MODELLO DELL'ANNO PRECEDENTE

PART DIFFERENT OR NOT PRESENT IN THE REVIOUS YEAR MODEL

5M

MOTORE CON CAMBIO A 5 MARCE
ENGINE WITH 5 GEARS SPEED

6M

MOTORE CON CAMBIO A 6 MARCE
ENGINE WITH 6 GEARS SPEED

KS

MOTORE CON SOLO KICK STARTER
ENGINE WITH KICK STARTER ONLY

ES

MOTORE CON AVVIAMENTO ELETTRICO
ENGINE WITH ELECTRIC STARTER

X

RICAMBIO NON DISPONIBILE ALLA VENDITA
PART CAN NOT BE SOLD SEPARATELY

Le illustrazioni riportate in questo manuale sono fornite solo come riferimento e possono variare dal prodotto effettivo,

Dati indicativi soggetti a modifiche senza impegno di preavviso.

The illustrations in this manual are for reference only and may vary from the actual product.

All data are subject to modification without prior notice.

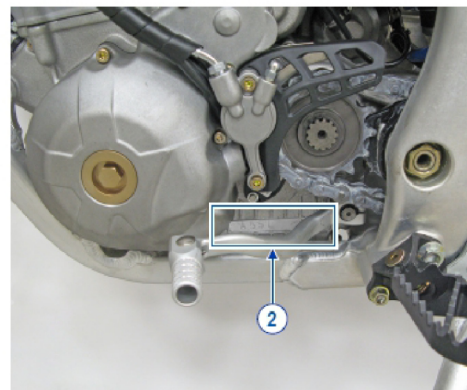
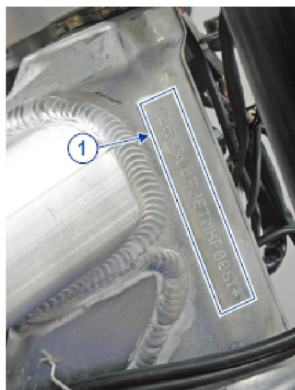



**2T300FIEN20-M
MOTORE - ENGINE**

**SOMMARIO
TABLE OF CONTENTS**

CILINDRO - CYLINDER.....	4
MOTORINO VALVOLA - ELECTRIC VALVE SYSTEM.....	7
ALBERO MOTORE - PISTONE - CRANKSHAFT - PISTON.....	9
CARTER FRIZIONE - CLUTCH CASE.....	11
FRIZIONE - CLUTCH.....	13
BASAMENTO - CONTRALBERO - CRANKCASE - BALANCE SHAFT.....	16
FORCHETTE CAMBIO - GEAR FORKS.....	19
CAMBIO - GEARBOX.....	22
MESSA IN MOTO - KICK STARTER.....	25
ACCENSIONE - IGNITION.....	27
SISTEMA INIEZIONE - INJECTION SYSTEM.....	29



2T300FIEN20-M
MOTORE - ENGINE

CILINDRO
CYLINDER

1

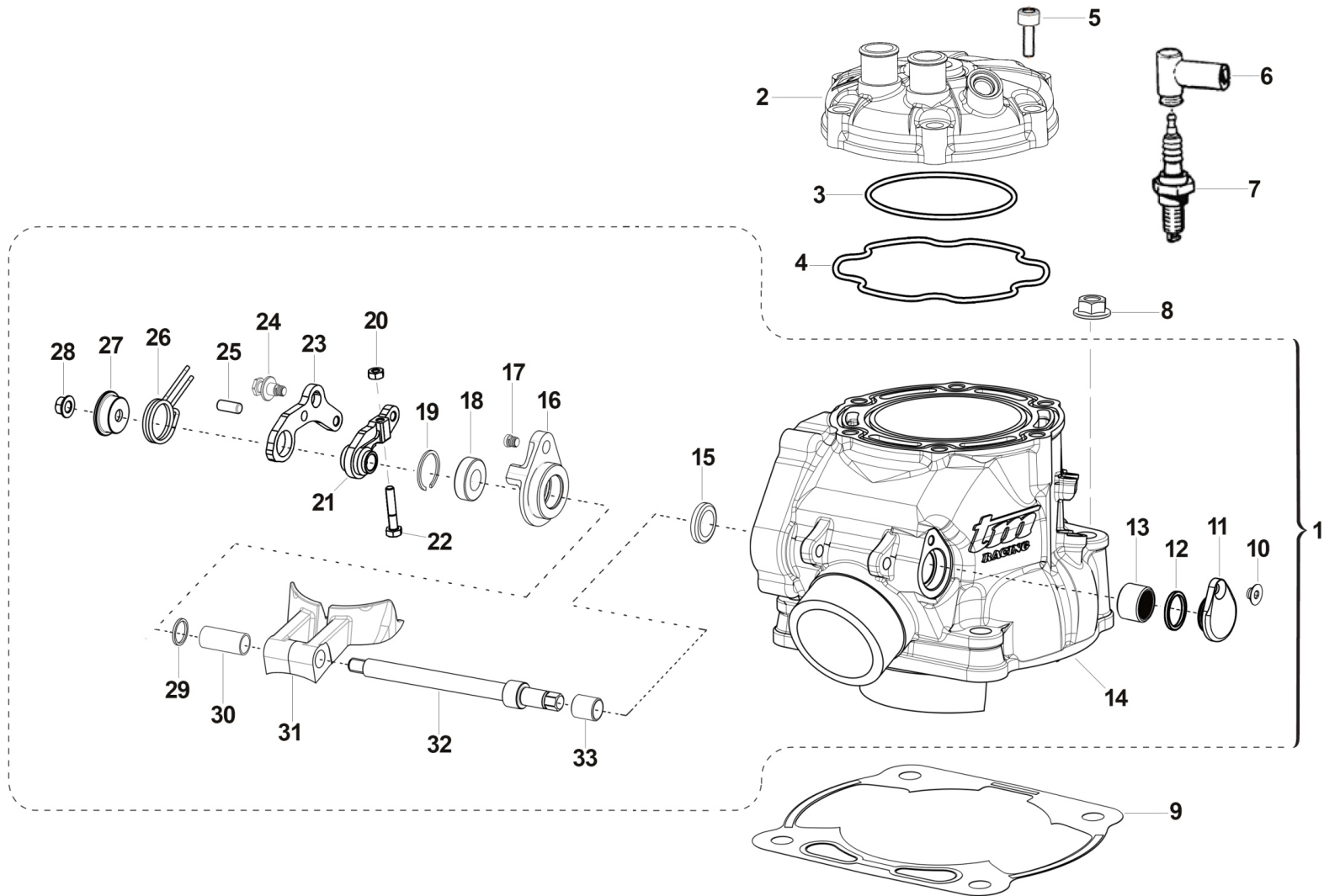



2T300FIEN20-M
MOTORE - ENGINE

CILINDRO
CYLINDER

1

Pos.	Codice	Q.tà	Note	Descrizione	Description
1	01315	1		CILINDRO 300 2T IE CPL	CYLINDER 300 2S Fi MY19 ASSY
2	02258	1		TESTA 300 2T IE	HEAD 300 2S FI
3	12262	1		O RING TESTA 300cc PICCOLO M.15->	O-RING 300 CC HEAD LITTLE M.15->
4	12263	1		O RING 250/300 SPECIALE TESTA M.15->	O-RING 250/300 HEAD BIG M.15
5	49503	8		VITE TCEI 8X35	BOLT TCEI 8X35
6	21017	1		PIPETTA CANDELA NGK LB05EMH	CAP, NGK SPARK PLUG LB05EMH
7	06036	1		CANDELA 250/300 2T M19-> NGK BKR8EIX	SPARK PLUG NGK BKR8EIX
8	F49874	4	MY20	DADO M 10 X 1,25 CH 12 FLANGIATO	NUT FLANGED M 10x1,25 T.12mm
9	05281.20	1		GUARN. B/CIL 300 M.2015 0.2	GASKET, CYL 300 M.15 0,2
9	05281.30	1		GUARN. B/CIL 300 0.3 M.15->	GASKET, CYL 300 M.15 0,3
9	05281.40	1		GUARN. B/CIL 300 M.2015 0.4	GASKET, CYL 300 M.15 0,4
9	05281.50	1		GUARN. B/CIL 300 0.5 M.15->	GASKET, CYL 300 M.15 0,5
10	49399	1		VITE TSEI 5X12	BOLT TSEI 5x12
11	30217	1		TAPPO SX ALB.COM.VALV.PAL.125	SIDE COVER
12	F12308	1		O RING 17,5 - 1,5	O-RING 17,5 - 1,5
13	19044	1		GABBIA A RULLI FRENO POST.	NEEDLE BUSH REAR BRAKE PEDAL
14	01314	1		CILINDRO 300 2T IE NUDO	CYLINDER 300 2S Fi MY19
15	04115	1		PARAOLIO G 12X18X3	OIL SEAL 12x18x3
16	26258	1		FLANGIA PORTACUSC.ALB.VALV.250/300 IE	FLANGE, BEARING HOLDER
17	49757	1		VITE TBCE 5 X 12	BOLT TBCE 5X12
18	03156	1		CUSCINETTO V.SC.C.12 698LLU/5K	BUSH, EXHAUST VALVE 698LLU
19	49220	1		SEEGER INT.19	SEEGER I 19
20	49630	1		DADO M 4 (BASSO)	NUT 4mm, LOW
21	28262	1		LEVA INTERNA COMANDO VALVOLE EES-2 250/300 2019	LEVER, INTERNAL, 250/300
22	49738	1		VITE TE 4X20	BOLT TE 4X20
23	28263	1		LEVA ESTERNA COMANDO VALVOLE EES-2	LEVER, EXTERNAL, VALVE
24	26168	1		PERNO MOLLA EES-2 16066	PIN, SPRING
25	F19536	1		RULLO D. 5 X 12 M6 DIN 6325	PIN 5X12



2T300FIEN20-M
MOTORE - ENGINE

CILINDRO
CYLINDER

1

Pos.	Codice	Q.tà	Note	Descrizione	Description
26	16066	1		MOLLA EES-2	SPRING
27	26167	1		PIATTELLO GUIDA MOLLA EES-2 16066	COLLAR, SPRING
28	49676	1		DADO M 6X1 FLANG. AUTOBL.ACC.	NUT, FLANGED M6 X 1 S.B.
29	26130.12	1		SPESS. REG. CIL.125 2012 1.2	SPACER CYL. 125 ->12 1.2
29	26130.13	1		SPESS. REG. CIL.125 2012 1.3	SPACER CYL. 125 ->12 1.3
29	26130.14	1		SPESS. REG. CIL.125 2012 1.4	SPACER CYL. 125 ->12 1.4
29	26130.15	1		SPESS. REG. CIL.125 2012 1.5	SPACER CYL. 125 ->12 1.5
29	26130.16	1		SPESS. REG. CIL.125 2012 1.6	SPACER CYL. 125 ->12 1.6
29	26130.17	1		SPESS. REG. CIL.125 2012 1.7	SPACER CYL. 125 ->12 1.7
29	26130.18	1		SPESS. REG. CIL.125 2012 1.8	SPACER CYL. 125 ->12 1.8
29	26130.19	1		SPESS. REG. CIL.125 2012 1.9	SPACER CYL. 125 ->12 1.9
30	26147	1		BOCCOLA DIST. CIL.250/300 2015	BUSH
31	22262.19	1		VALVOLE SCARICO 300 ES MY 2019	POWER VALVE 300 2S ES MY19
32	28256	1		ALBERO COMANDO PALETTE 250	SHAFT BOOSTER 250/300
33	19061	1		BOCCOLA IR 8X12X12.5	BUSH, IR 1X12X12,5

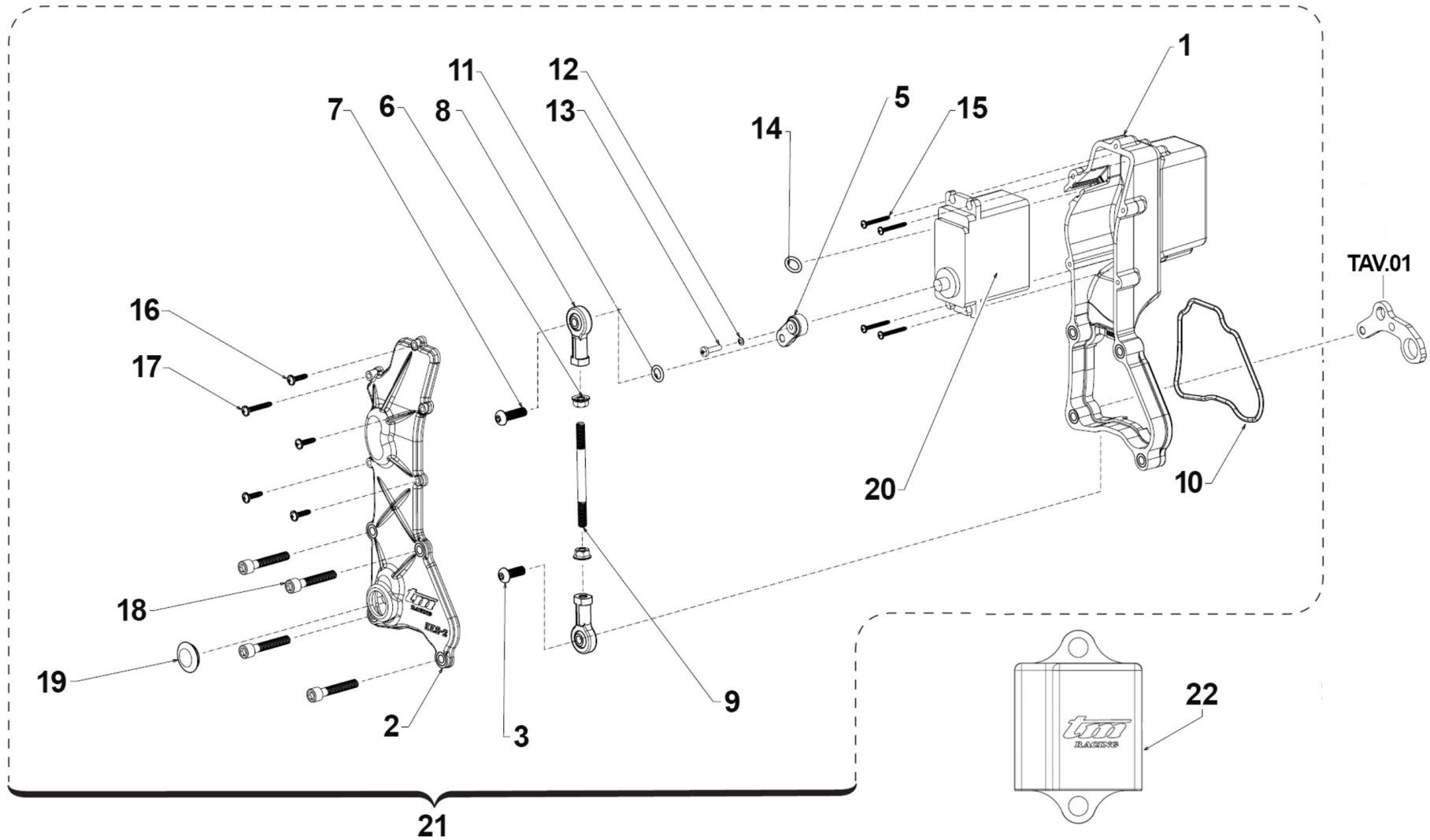



2T300FIEN20-M
MOTORE - ENGINE

MOTORINO VALVOLA
ELECTRIC VALVE SYSTEM

2

Pos.	Codice	Q.tà	Note	Descrizione	Description
1	30285	1		CARTER EES-2 250/300 2T IE	BOX, PLASTIC
2	30286	1		COPERCHIO CARTER EES-2 250/300 2T IE	COVER, PLASTIC
3	49890	1		VITE TBCE 5X14	SCREW TBCE 5X14
5	28266.0	1		LEVA SERVOMOTORE EES-2 DENTATURA 0	LEVER
5	28266.1	1		LEVA SERVOMOTORE EES-2 DENTATURA 1	LEVER
6	49632	2		DADO M 5	NUT 5mm
7	49929	1		VITE TBCE 5X18	BOLT
8	72251	2		SNODO MECCANISCO VALVOLA EES-2 250/300	JOINT
9	28264	1		ASTINA COLLEGAMENTO UNIBALL EES-2 250/300 2019	ROD
10	12042	1		O RING COP. VALVOLA EES-2	O-RING
11	F12301	1		O RING 106 4T PIOGGIA CAMBIO	O-RING, 106 GEAR F.S.
12	49700	1		RONDELLA 3 VALVOL.	WASHER
13	49304	1		VITE T.C. 3X12	BOLT
14	F12321	1		O RING BOCCOLA CENTR. CILINDRO	O-RING
15	49973	4		VITE STS-Plus KN6031 2.2X20 PLASTICA	BOLT
16	49984	4		VITE TCBL 3.0X 12 FL. PLASTICA	BOLT
17	49919	1		VITE TCBL 3.0X 20 FL. X PLAST.	BOLT
18	49478	4		VITE TCEI 5 X 30	BOLT TCEI 5X30
19	21009	1		TAPPO GOMMA COPERCHIO VALV.SC.	RUBBER, COVER
20	22500	1		SERVOMOTORE VALV.SCARICO HITEC	EL. ENGINE EXHAUST VALVE HITEC
21	22503.19	1		SERVOMOTORE V/SC. CPL 250/300 ES MY 2019	EL. ENGINE EXHAUST, ASSY
22	08023	1		CENTRALINA COMANDO VALV.SC. 250/300 EES-2	CDI, VALVE CONTROL

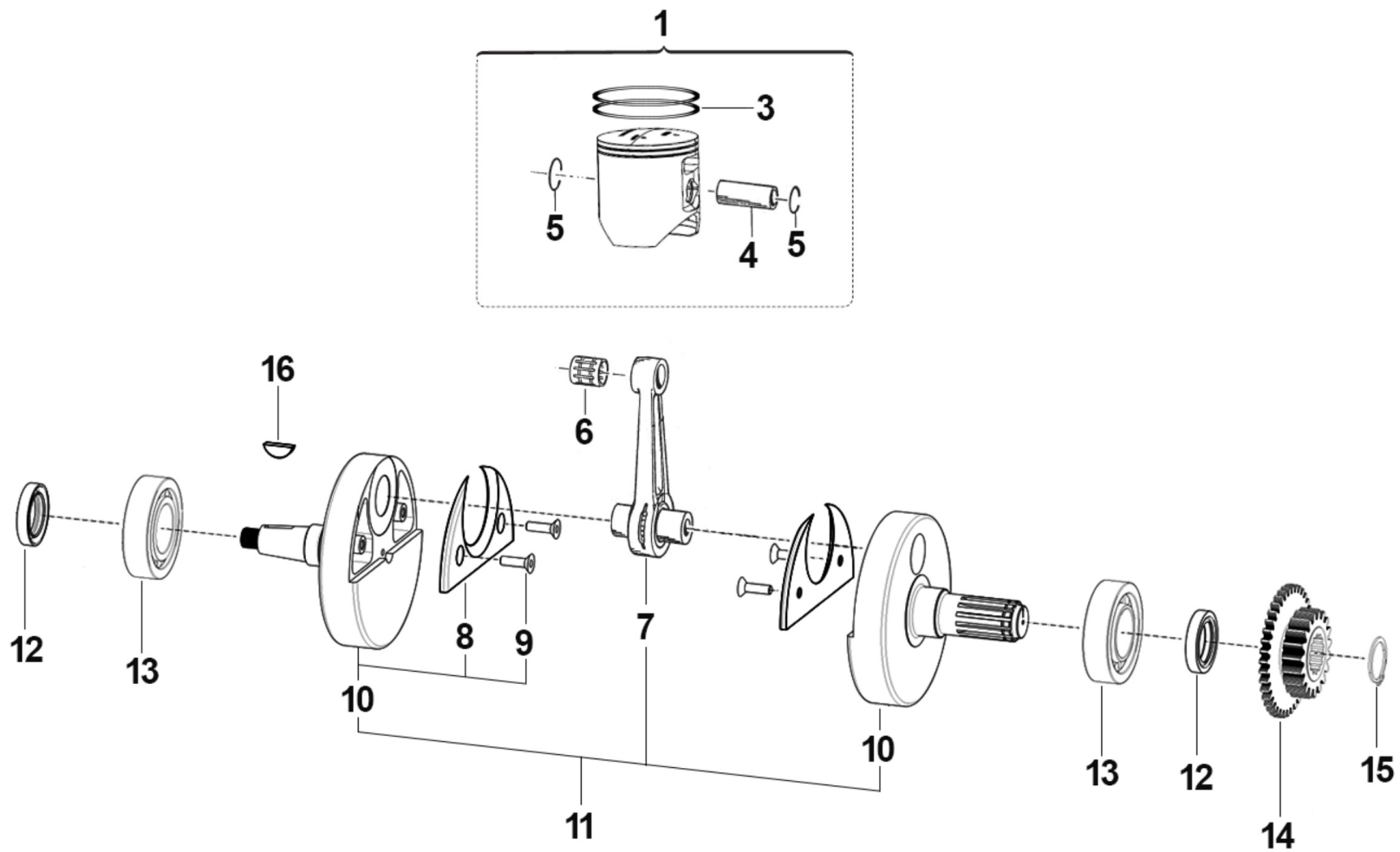



2T300FIEN20-M
MOTORE - ENGINE

ALBERO MOTORE - PISTONE
CRANKSHAFT - PISTON

3

Pos.	Codice	Q.tà	Note	Descrizione	Description
1	10305.94	1		PISTONE 71,94 2F 300 CPL M.19->	PISTON 71,94 2R 300 ASSY
1	10305.95	1		PISTONE 71,95 2F 300 CPL M.19->	PISTON 71,95 2R 300 ASSY
1	10305.96	1		PISTONE 71,96 2F 300 CPL M.19->	PISTON 71,96 2R 300 ASSY
3	11050	2		SEGMENTO 300cc VERTEX D. 72,00	PISTON RING 300cc VERTEX
4	09250	1		SPINOTTO PISTONE 250/300cc	PIN, PISTON 250/300cc
5	09251	2		ANELLINI FERMA SPINOT.250/300	CLIP, PISTON PIN 250/300
6	19250	1		GABBIA SPINOTTO 250/300 cc	TOP END BUSH 250/300cc
7	18246	1		BIELLA 250/300 M.05/-> P. CPL	CONROD KIT, 250/300 M.05/->
8	18270	2		GUANCETTA SEMIALB. 250/300Fi	STUFFERS, CRANKSHAFT
9	49404	4		VITE TSEI 6X16	BOLT TSEI 6x16
10	18268	1		COPPIA SEMIALBERI 250/300 EV18	CRANK LH + RH
11	18266.19	1		ALBERO MOTORE 250/300 2T ES MY 2019	CRANKSHAFT ASSY
12	04112	2		PARAOLIO 25X38X7 125 MF1	OIL SEAL 25 x 38 x 7
13	03037	2		CUSCINETTO ALBERO MOTORE NJ206 gabbia PEEK	BUSH, NJ206 CRANKSHAFT
14	40243	1		PIGNONE C.PRIM.250/300 Z19 M18 PER CONTRALBERO	GEAR, PRIMARY 19 T
15	49252	1		SEEGER PIGNONE CATENA 250 E 25	CIRCLIP D.25 FRONT SPROKET 250
16	49012	1		CHIAVETTA PIGNONE COPPIA 250	WOODRUFF KEY, 250/300 19x7,5x5

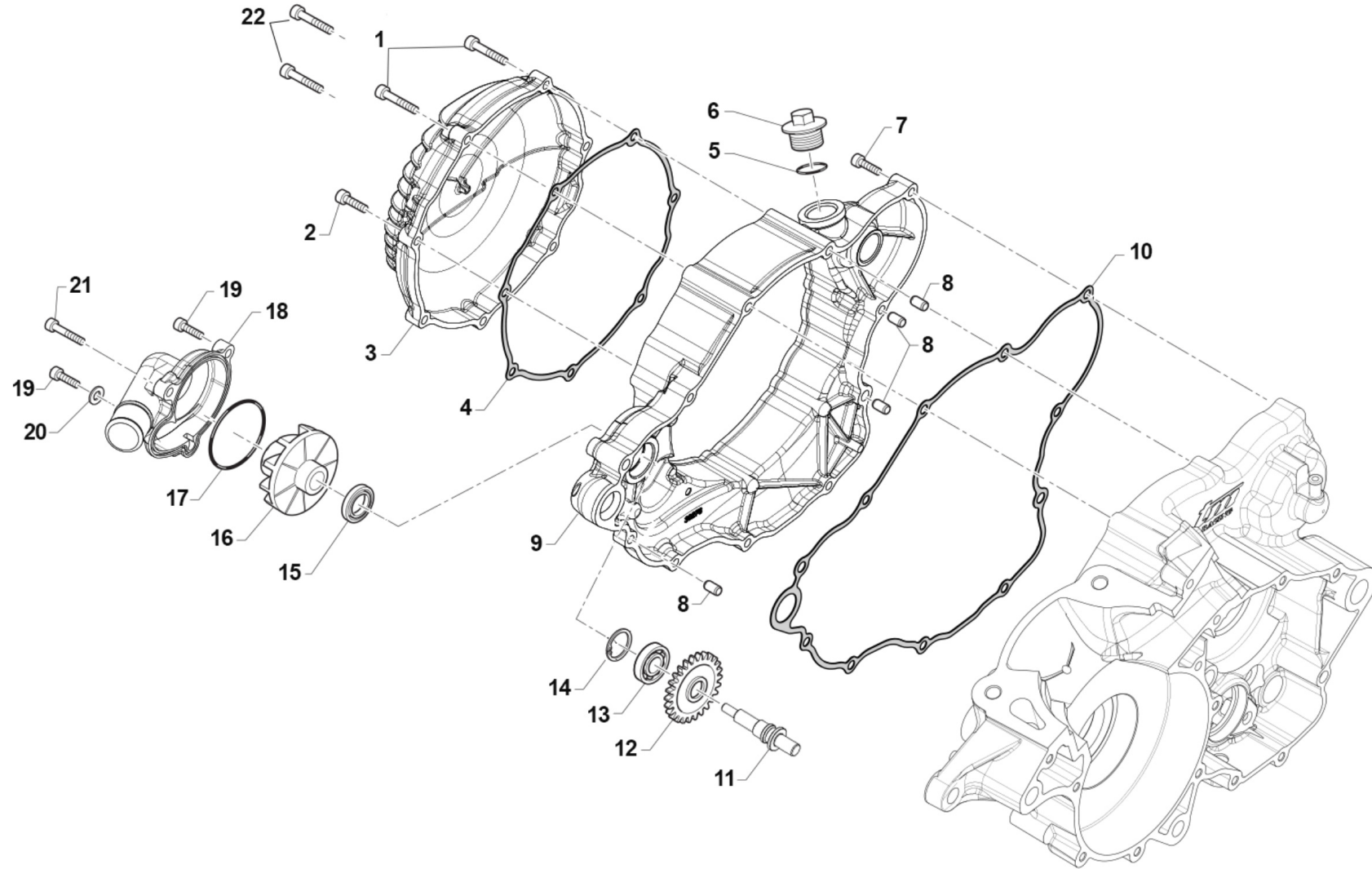



2T300FIEN20-M
MOTORE - ENGINE

CARTER FRIZIONE
CLUTCH CASE

4

Pos.	Codice	Q.tà	Note	Descrizione	Description
1	49986	2		VITE TCEI 5X75	BOLT TCEI 5 X 75
2	49477	3		VITE TCEI 5X25 UNI 5931	BOLT TCEI 5X25
3	30277	1		COPERCHIO FRIZIONE 250/300 2T MY'19	COVER, CLUTCH 250/300 TS M.19->
4	05284	1		GUARN. COP. FRIZIONE 250/300 2T ES M19->	GASKET, CLUTCH COVER 250/300 2S ES MY 19
5	F49920	1		RONDELLA ALL 20.4X26X1.5	WASHER 20,4X26X1,5 ALUM.
6	F49925	1		TAPPO CARICO OLIO M20X1.5	OIL PLUG M20X1,5
7	49477	9		VITE TCEI 5X25 UNI 5931	BOLT TCEI 5X25
8	26041	2		GRANO CENTRAGGIO D.7X8 F.5,2	DOWEL PIN 7 x 8 Hole 5,2
9	30288	1	MY20	CARTER FRIZIONE 250/300 2020	COVER, INTERNAL, CLUTCH
10	05285	1	MY20	GUARN. CARTER INT. FRIZ. 250/300 2T ES MY 2020	GASKET, CLUTCH CASE
11	28068	1		ALBERINO POMPA ACQUA 250 SC.	SHAFT WATER PUMP 250
12	40074	1		INGR COMANDO POMPA H2O 250 M18	GEAR, WATER PUMP
13	03014	1		CUSCINETTO 608 ZC3 POMPA SCHER	BUSH, WATER PUMP 608 Z C3
14	49215	1		SEEGER POMPA ACQUA 22	CIRCLIP D.22 WATER PUMP
15	F04363	1		PARAOLIO 8X22X5 250/09->	OIL SEAL 8x22x5 (250F/09)
16	F28679	1		GIRANTE POMPA ACQUA 250N	IMPELLER, H2O PUMP 250Fi
17	12028	1		OR COP.POMPA H2O 2T 250/300 18	O-RING
18	30275	1		COPERCHIO POMPA ACQUA 250/300 MY 2019	COVER, WATER PUMP 250/300 2S ES
19	49476	2		VITE TCEI 5X20 UNI 5931	BOLT TCEI 5X20
20	49119	1		RONDELLA 5 x 9 x 1,5 ALLUMINIO	WASHER, 5 x 9 x 1.5 ALLUMINIUM
21	49570	1		VITE TCEI 5X50	SCREW TCEI 5X50
22	49478	2	MY20	VITE TCEI 5 X 30	BOLT TCEI 5X30



2T300FIEN20-M
MOTORE - ENGINE

FRIZIONE
CLUTCH

5

Pos.	Codice	Q.tà	Note	Descrizione	Description
1	30265.19	1		COP. FRIZ/IDR 2T 250/300 ES MY 2019 CPL	PUMP, CLUTCH, ASSY
2	12091	1		O RING CORPO CARTUCCIA FR.COMP	O-RING
3	F19517	1		SFERA X PIST.FRIZ.IDRAUL.250N	BALL IDR. CLUTCH PISTON 250N
4	12268	1		O RING PISTONE FRIZ.250/300 2T 19 VERDE	O-RING CLUTCH PISTON 250/300 TS M.19->
5	F35559	1		PISTONCINO CIL.FRIZ.D.27XRING	PISTON
6	F16445	1		MOLLA PIST. FRIZ. 250N CONICA	SPRING
7	F16453	6		MOLLA FRIZIONE 2/4T 250/450	SPRING, CLUTCH 2/4T 250/450
8	25253	1		PIATTO SPING. 250/300 + 4T	PLATE, CLUTCH PRESSURE
9	09006	1		ANELLINO FERMA SPINOTTO 80/85	CLIP, 80/85cc PISTON PIN
10	19022	1		GABBIA A RULLI RAD. AXK 1528	BUSH CAGE AXK 1528, RADIAL
11	19023	1		RONDELLA GABBIA RULLI AS 1528	WASHER, NEEDLE CAGE AS 1528
12	F35582	1		FUNGO FRIZIONE IDRAULICA 2015	PIECE, CLUTCH LIFTER
13	F35533	8		DISCO FRIZ. GUARN. ADLER 2,80	CLUTCH PLATE,FIBER 2,80mmADLER
14	35250	7		DISCO FRIZ. ACC. 1,8 mm 250+4T	CLUTCH PLATE, STEEL 1,8mm 250
15	48250	2		SPESSORE COPPIA PRIMARIA 250	SPACER, PRIMARY GEAR 250cc
16	49060	1		DADO TAMBUR.FRIZ. ALB.PRIM. 250/300 M18X1.5	NUT, CLUTCH CENTER 250cc
17	35050	1		RONDELLA X FRIZ. 250/300/4T	CLUCTH WASHER 250/300/F
18	25255	1		TAMBURELLO FRIZIONE 250/300 2T ES MY 2019	CENTRAL HUB
19	35503	1		ASTINA FRIZIONE IDRAULICA 250/300 IE M19	ROD, CLUTCH
20	40245.19	1		COPPIA PRIM. 250/300 2T ES z57 CPL MY 2019	PRIMARY GEAR ASSY
21	35262	1		DISCO BATTUTA GOMMINI FRIZ.250	PLATE, CLUTCH BASKET 250cc
22	49727	8		VITE PARASTRAPPI K9 M7X1X12.5	SCREW, M7X1X12,5 K9 ENGINE
23	25254	1		CAMPANA FRIZ. 250/300 M.2019	BASKET, CLUTCH
24	21005	8		GOMMINO PARASTRAPPI FRIZIONE	RUBBER, CLUTCH BASKET
25	40242	1		CORONA COPPIA PRIM. 250/300 2T ES Z57 MY 2019	GEAR, PRIMARY 57 T
26	F19510	1		GABBIA A RULLINI K 27X32X23.8	NEEDLE CAGE 27 x 32 x 23.8
27	F26422	1		BOCCOLA INGR.TRASM.PRIM. 250N	BUSH, PRIMARY GEAR 250Fi
28	35264	1		VITE SPURGO OLIO FRIZ.IDR.6X1	SCREW AIR BLEED HYDRAUL.CLUTCH



2T300FIEN20-M
MOTORE - ENGINE

FRIZIONE
CLUTCH

5

Pos.	Codice	Q.tà	Note	Descrizione	Description
29	30269	1		COP. FRIZ/IDR NUDO 250/300 M19	PUMP, CLUTCH
30	49535	2		VITE TCEI 5X35	BOLT TCEI 5X35
31	40075	1		PROTEZIONE PIGNONE 250/300 IE	PROTECTION, PLASTIC
32	40042	1		PROTEZIONE PIGNONE ERGAL 250/300 2T ES MY 2019	PROTECTION, ERGAL
33	49474	1		VITE TCEI 5X16 UNI 5931	BOLT TCEI 5X16

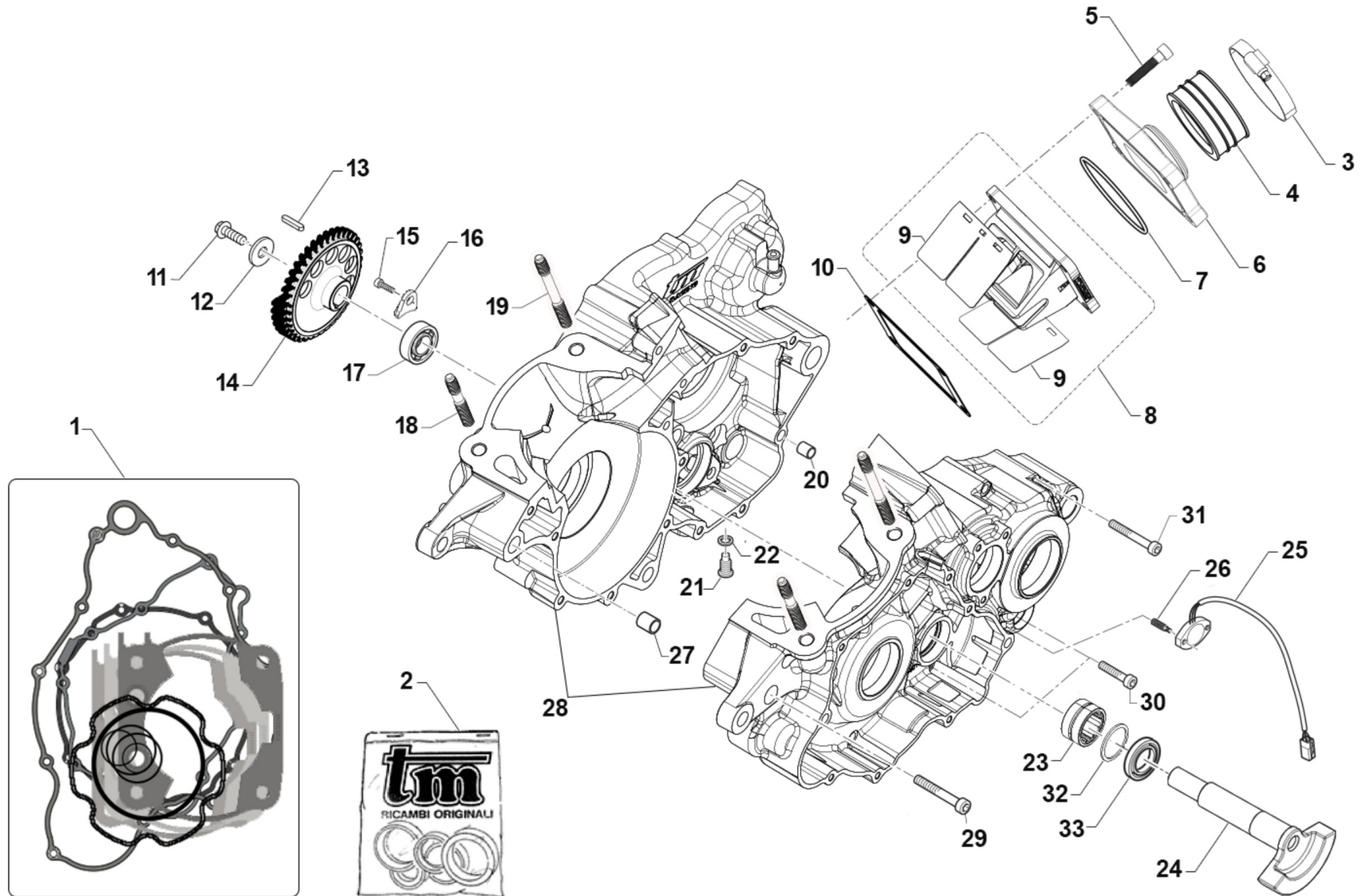



2T300FIEN20-M
MOTORE - ENGINE

BASAMENTO - CONTRALBERO
CRANKCASE - BALANCE SHAFT

6

Pos.	Codice	Q.tà	Note	Descrizione	Description
1	05620.20	1	MY20	KIT GUARNIZIONI + OR 300cc 2T ES MY 2020	
2	04029.19	1		KIT PARAOLI 250/300 2T ES MY 2019	OIL SEAL KIT 250/300 2T ES MY 2019
3	51054	2		FASCETTA SM9 D.52	CLAMP SM9 D.52mm
4	13009	1		MANICOTTO COLLETTORE ASP.97/14	MANIFOLD RUBBER,INTAKE M.97/14
5	49486	4		VITE TCEI 6X30	BOLT TCEI 6X30
6	30314.14	1		CONVOGL. P/LAM 250/3 14/-> VF3	MANIFOLD, INTAKE
7	12255	1		O RING COLLETT.ASP.250/300 14	O-RING, INLET MANIFOLD 250/300
8	20258	1		PACCO LAM 250/300 VF3 07/->	REEDS BOX VF3 250/300 M. 07/->
9	20076	1		LAMELLE V-FORCE3 250/300 07/->	REEDS, V-FORCE3 250/300 07/->
10	05268	1		GUARN. PACCO LAMELLE 250	GASKET, REED BLOCK 250/300
11	49363	1		VITE TE F/R 8X16 Ch.10	BOLT 8X16 T.10mm
12	49100	1		RONDELLA TESTATA 8x18x3	WASHER, HEAD 8x18x3
13	49969	1		CHIAVETTA CONTRALBERO 250/300 2T A 3X3X12	WOODRUFF KEY
14	40257	1		INGR. CONTRALBERO 250/300 M18	GEAR, BALANCE SHAFT
15	49962	1		VITE TCEI 6X12 BASSA / F.GUIDA	BOLT
16	26156	1		PIASTRINO BLOC.CUSC.C.A.125 OK	PLATE, BEARING HOLDER 125 OK
17	03049	1		CUSCINETTO CONTRALBERO MOTO 2T	BEARING
18	49044	2	MY20	PRIGIONIERO CARTER/CILIND.250/300 ES Ant.	STUD, M10 X 1.25 L.57
19	49045	2	MY20	PRIGIONIERO CARTER/CILIND. 250/300 ES Post.	STUD, M10 X 1.25 L.81,5
20	F26304	1		GRANO RIFERIMENTO 6.5X8X9.5 4T	GRUB SCREW 6.5X8XX9.5 4S
21	49301	1		TAPPO OLIO C/CALAM. 2T	OIL PLUG WITH MAGNET
22	49103	1		RONDELLA 14X20X1,5 ALLUMINIO	WASHER, 14 X 20 X 1.5 ALUMINUM
23	19072	1		ASTUCCIO A RULLI NK 2016 250/300 2T I.	NEEDLE CAGE
24	18267	1		CONTRALBERO 250/300 M.2018	BALANCE SHAFT
25	F08340.1	1		SENSORE POSIZ.CAMBIO 250 MOTO3 CABLATO	SENSOR, GEAR POSITION
26	49713	2		GRANO 6X20 FRIZ. KART-CROSS	GRUB SCREW
27	F26428	1		GRANO RIFERIMENTO 12X13 F10.2	GRUB SCREW 12X13 H.10,2mm
28	30300.20	1	MY20	BASAMENTO MOTORE 300 2T ES MY 2019	CRANKCASE 300 2T ES MY19



2T300FIEN20-M
MOTORE - ENGINE

BASAMENTO - CONTRALBERO
CRANKCASE - BALANCE SHAFT

6

Pos.	Codice	Q.tà	Note	Descrizione	Description
29	49508	1		VITE TCEI 8X60	BOLT
30	49487	3		VITE TCEI 6X35 UNI 5931	BOLT TCEI 6X35
31	49490	11		VITE TCEI 6X50 UNI 5931	BOLT TCEI 6X50
32	F49915	1		SEEGER I28 FILTRO COPPA OLIO (J28 x fori)	SEEGER OIL FILTER
33	04035	1		PARAOLIO 20x30x7 PTFE	OIL SEAL 20 x 30 x 7 PTFE

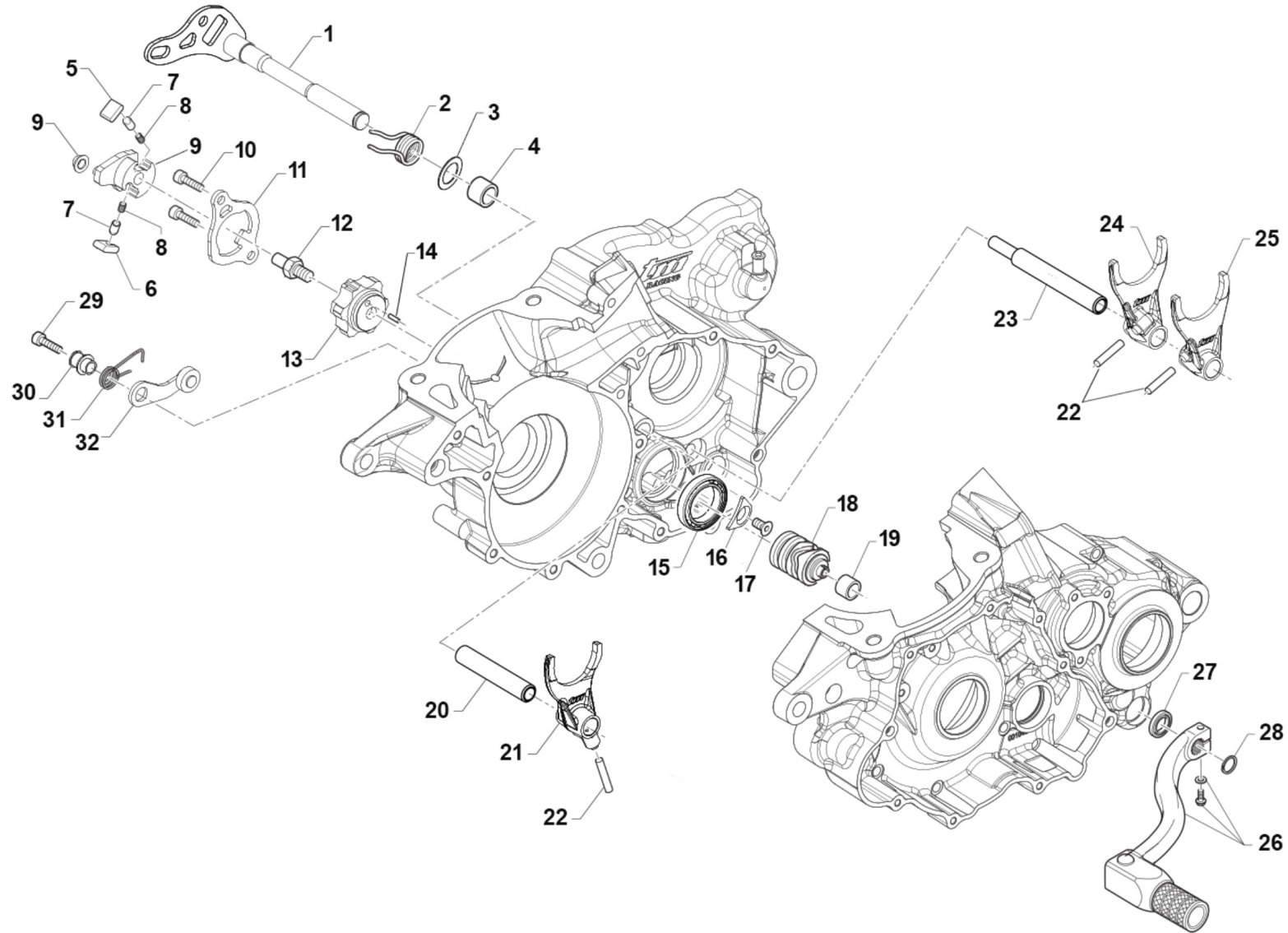



2T300FIEN20-M
MOTORE - ENGINE

FORCHETTE CAMBIO
GEAR FORKS

Pos.	Codice	Q.tà	Note	Descrizione	Description
1	28105	1		ALBERO COMANDO CAMBIO 250/300 IE CPL	GEAR SHIFT SPINDLE, ASSY
2	16065	1		MOLLA RITORNO LEVA CAMBIO 250 2T IE	SPRING
3	49073	1		RONDELLA 12,1X22X1 125TAG	WASHER 12,1X22X1 125 MF1/2
4	19060	1		ASTUCCIO A RULLI HK 1212	NEEDLE CAGE HK 1212
5	F26587	1		CRICCHETTO SX (HT) 250 M3	RATCHET LH
6	F26588	1		CRICCHETTO DX (HT) 250 M3	RATCHET RH
7	F26592	2		PUNTALE CRICCHETTO (HT)	PUSH ROD
8	F16469	2		MOLLA PER PUNTALE EDM	SPRING
9	F26620	1		PORTACRICCHETTI HT 250MX	GEAR
10	49482	2		VITE TCEI 6X14	BOLT TCEI 6X14
11	26160	1		PIASTRINO RIENTRO CRIC.250 M18	PLATE
12	F49873	1		PERNO FILETTATO PER PORTACRICCHETTI (HT)	THREADED PIN FOR RATCHET HOLDER (HT)
13	F26589	1		TESTA ALBERO DESMODROMICO (HT)	CAM, HEAD
14	F19501	1		GABBIA A RULLI 10X13X10 4T	NEEDLE CAGE 10X13X10 F.S.
15	F03381	1		CUSCINETTO 61805	BEARING
16	F48352	1		PIASTRINO FISSA CUSCINETTO D72	PLATE
17	49403	1		VITE TSEI 6X12 ZINCATO	SCREW TSEI 6x12
18	33253.1	1		ALBERO DESM.250/300 INTEGR.M18	CAM, GEAR SHIFT
19	26260	1		BOCCOLA ALB. DESMODROMICO 250/300 2T I.E.	BUSH
20	33260	1		PERNO FORCHETTA A.P.250 M2018	PIN, MAINSHAFT FORK
21	33018	1		FORCHETTA ALB.PRIM.250/300 M18 4A E 5A	FORK, MAINSHAFT
22	F19533	3		RULLO D.6 X 15	PIN
23	33025	1		PERNO FORCHETTA AS 250/300 M18	PIN, COUNTERSHAFT FORKS
24	33023	1		FORCHETTA A.S.1^3^ 250/300 M18 1A E 3A	FORK 1, COUNTERSHAFT
25	33024	1		FORCHETTA A.S.2^ 250/300 M18 2A	FORK 2, COUNTERSHAFT
26	43049	1		LEVA CAMBIO 250 / 300 2T E.S. 19	GEAR LEVER 250 / 300 T.STR. EL.ST. M.19->
27	04038	1		PARAOLIO LEVA CAMBIO 250/300 2T I 12x20x5 l.parapolv.	OIL SEAL
28	49212	1		SEEGER E12 LEVA CAMBIO	CIRCLIP D.12 - EXTERNAL



2T300FIEN20-M
MOTORE - ENGINE

FORCHETTE CAMBIO
GEAR FORKS

7

Pos.	Codice	Q.tà	Note	Descrizione	Description
29	49485	1		VITE TCEI 6X25 UNI 5931	BOLT TCEI 6x25
30	26007	1		DISTANZIALE MOLLA BLOCCAMARCE	SPACER, STOP GEAR SPRING
31	F16447	1		MOLLA BLOCCA MARCE 250N	SPRING, STOP GEAR 250 4S
32	F26479	1		PIASTRINO BLOCCA MAR. 250Fi 12	PLATE, STOP GEAR 250 4S 12->

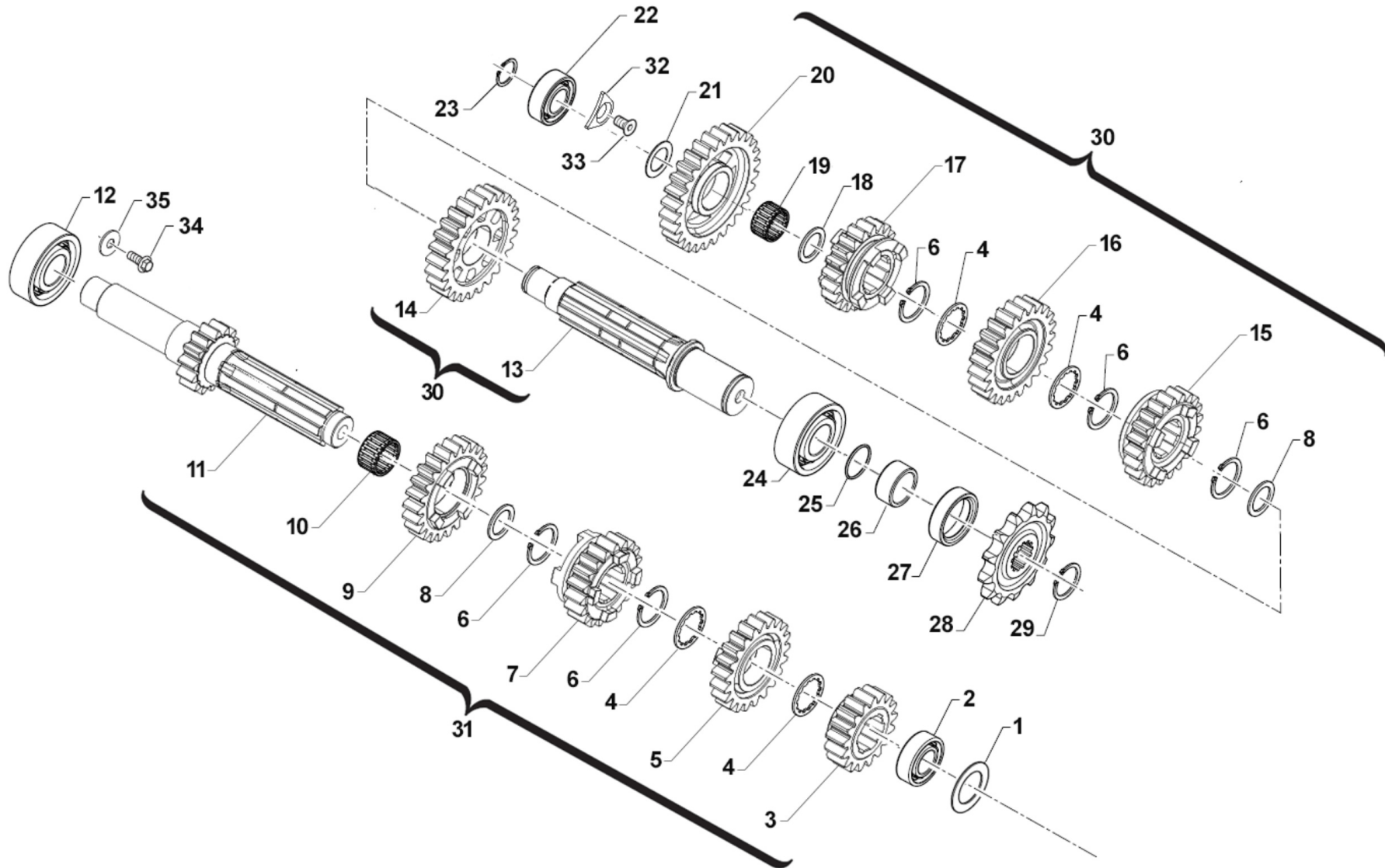



2T300FIEN20-M
MOTORE - ENGINE

CAMBIO
GEARBOX

Pos.	Codice	Q.tà	Note	Descrizione	Description
1	F48401.30	1		RASAMENTO Ø20,3 x Ø35,9 x 0,30	SHIM
2	F03379	1		CUSCINETTO 16004 C3	BEARING
3	40255	1		INGRAN A.P. 2a Z 17 250 CR/E	GEAR, 2ND (17T) MAINSHAFT MX/E
4	48251	4		SPESSORE DENT.CAMBIO 250/KZ10B	SPACER, GEAR 250cc
5	40260	1		INGRAN A.P. 4a Z 21 250 CR/E	GEAR, 4TH (21T) MAINSHAFT MX/E
6	49255	5		SEEGER RETTIFICATO CAMBIO 250	CIRCLIP, GEAR BOX 250cc
7	40258	1		INGRAN A.P. 3a Z 19 250 CR/E	GEAR, 3RD (19T) MAINSHAFT MX/E
8	48254	2		SPES.RE CAMBIO 25.2X31.8X1 250	SPACER,GEAR BOX250 25.2X31.8X1
9	40266	1		INGRAN A.P. 5a Z 24 250/ENDURO	GEAR, 5TH (24T) MAINSHAFT END
10	19051	1		GABBIA ING. V AP. 250	NEEDLE CAGE K 25x29x10 AP250
11	40256	1		ALBERO PRIMARIO EN Z14/250 M18	MAINSHAFT 14 T
12	03252	1		CUSCINETTO 6205 C4 A/P 250/K9	BUSH, MAINSHAFT 250 / KZ
13	40271	1		ALBERO SECONDARIO 250 M.2018	COUNTERSHAFT
14	40275	1		INGRAN A.S. 2a Z 25 250 CR/E	GEAR, 2ND(25T)COUNTER.MX/E 250
15	40279	1		INGRAN A.S. 4a Z 21 250 CR/E	GEAR, 4TH(21T)COUNTER.MX/E 250
16	40277	1		INGRAN A.S. 3a Z 23 250 CR/E	GEAR, 3RD(23T)COUNTER.MX/E 250
17	40280	1		INGRAN A.S. 5a Z 19 250/ENDURO	GEAR, 5TH(19T)COUNTER. END.250
18	48252	1		SPESSORE CAMBIO 20X29X1 250	SPACER, GEAR 250 20X29X1
19	19012	1		GABBIA A RULLI K 20X24X10	BUSH NEEDLE CAGE 20 X 24 X 10
20	40273	1		INGRAN A.S. 1a Z 28 250/ENDURO	GEAR, 1ST(28T)COUNTERSH. E 250
21	48059	1		Spessore alb.sec. 2T IE 17x28x3.5	SPACER
22	03251	1		CUSCINETTO 6203/C3 A/P A/S 250	BUSH, MAINSHAFT COUNTER.250/4T
23	F49876	1		SEEGER E 17 CAMBIO 250/300 2T 19->	SEEGER
24	03020	1		CUSCINETTO RULLI NJ205ET2XC3 (BANCO 85/100 M.18)	BUSH CRANKSHAFT 85/100->18 NJ205ET2XC3
25	12252	1		O RING PIGNONE CAT.+DIS.AL.MOT	O-RING, 25,12 x 1,78
26	26261	1		DISTANZIALE PIGNONE CAT.250/300 2T 19	SPACER, SPROCKET
27	04101	1		PARAOLIO PIGNONE CATENA 250	OIL SEAL 40 x 30 x 7
28	40212	1		PIGNONE CATENA Z12 250	SPROCKET 12T, DRIVE 250/300/4T



2T300FIEN20-M
MOTORE - ENGINE

CAMBIO
GEARBOX

8

Pos.	Codice	Q.tà	Note	Descrizione	Description
28	40214	1		PIGNONE CATENA Z13 250/2T e 4T	SPROCKET 13T, DRIVE 250/300/4T
29	49252	1		SEEGER PIGNONE CATENA 250 E 25	CIRCLIP D.25 FRONT SPROKET 250
30	40292	1		ALBERO PRIMARIO EN CPL 250/300 2T ES MY 2019	MAINSHFT EN ASSY
31	40293	1		ALBERO SECONDARIO EN CPL 250/300 2T ES MY 2019	COUNTERSHAFT EN ASSY
32	F48352	1		PIASTRINO FISSA CUSCINETTO D72	PLATE
33	49403	1		VITE TSEI 6X12 ZINCATO	SCREW TSEI 6x12
34	49962	1		VITE TCEI 6X12 BASSA / F.GUIDA	BOLT
35	49603	1		RONDELLA 6,4 X 12 X 1,5	WASHER 6x12

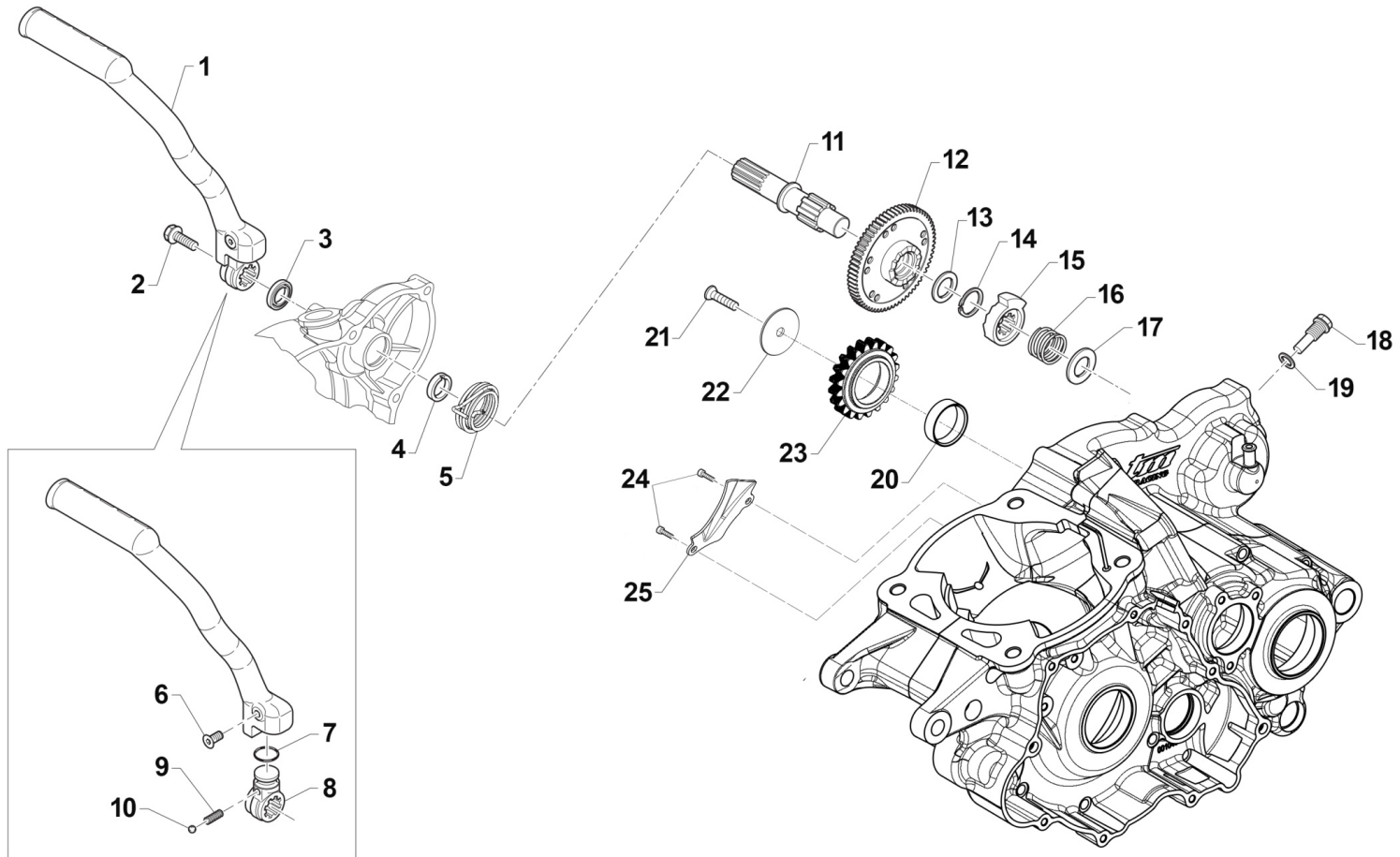



2T300FIEN20-M
MOTORE - ENGINE

MESSA IN MOTO
KICK STARTER

9

Pos.	Codice	Q.tà	Note	Descrizione	Description
1	43250.19	1		LEVA M/M 250/300 2T ES MY 2019	LEVER, KICK STARTER
2	49369	1		VITE TE F/R 8X10 Ch.10 M/M	BOLT 8X10 T.10mm(Kich Starter)
3	F04365	1		PARAOLIO LEVA M/M 250/09	OIL SEAL 18x28x6,5 KS LEVER
4	F26423	1		BOCCOLA MOLLA M/M. 250Fi	BUSH
5	F16428	1		MOLLA RICHIAMO AVVIAMENTO A P.	SPRING, KICK STARTER RETURN 4S
6	49414	1		VITE TSEI 6X30 NORMALE	BOLT TSEI 6X30
7	12260	1		O RING INTERNO LEVA M/M 250	O-RING INT.LEVER KICK START250
8	F43376	1		MOZZETTO KICK START CORTO 4T+2T	BLOCK, KICK STARTER 250N 08->
9	16039	1		MOLLA X SFERA LEVA M/M 250 CC	SPRING, BALL KICK-START. 250cc
10	43250.03	1		SFERA 1/4C X LEVA M/M 250 CC	BALL, KICK STARTER LEVER 250cc
11	F28657	1		ALBERO M/M 250Fi	SHAFT, KICK STARTER
12	40346	1		INGR. CONDUTTORE M/M 250/300	GEAR
13	F48353	1		SPESSORE PS 18X25X1	SPACER
14	F49835	1		SEEGER AV 18	SEEGER
15	F26424	1		BUSSOLA A CRICC.X K.S. 250N	BUSH
16	F16429	1		MOLLA CRICCHETTO AVV.A PEDALE	SPRING
17	F48354	1		SPESSORE TT 14 X 30 X 0,5	SPACER
18	49987	1		VITE DISIMP.CRICCH.M/M.250/300 2T ES MY 2019	BOLT
19	F49939	1		RONDELLA RAME 8,5X13X1,5	WASHER
20	26262	1		BRONZINA ING. FOLLE M/M RINF. 250/300 2T	BUSH
21	49440	1		VITE TE 6X14	BOLT TE 6X14
22	49981	1		RONDELLA 6x31x1.5 x ING.FOLLE RINF. 250/300 2T 2019	WASHER
23	40362	1		INGRANAGGIO FOLLE M/M RINF. 250/300	GEAR
24	49580	2		VITE TCEI 4X10	BOLT
25	26162	1		PIASTRINO CONV.OLIO 250/300 18	PLATE

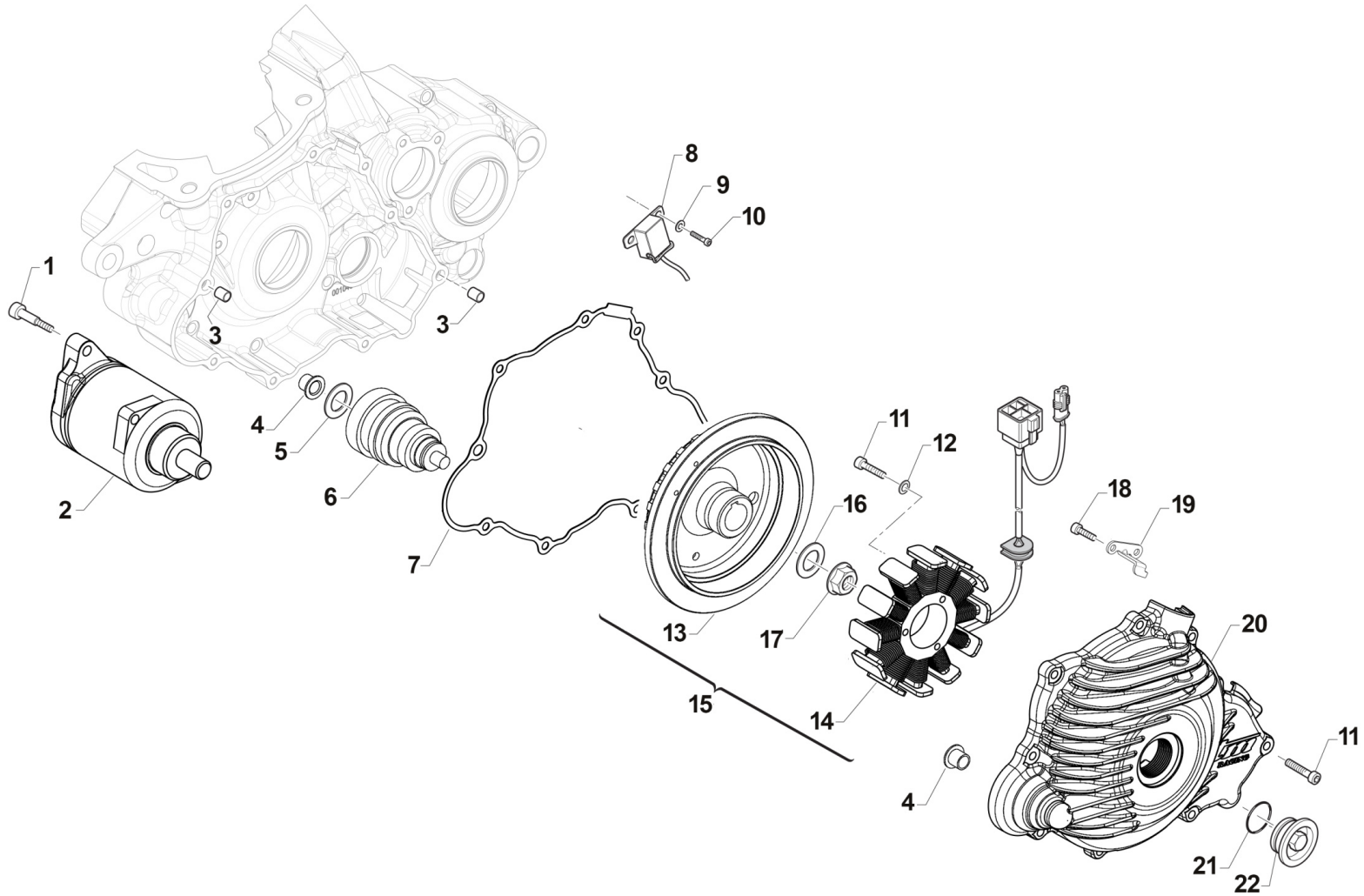



2T300FIEN20-M
MOTORE - ENGINE

ACCENSIONE
IGNITION

10

Pos.	Codice	Q.tà	Note	Descrizione	Description
1	49485	2		VITE TCEI 6X25 UNI 5931	BOLT TCEI 6x25
2	68206	1		MOTORINO AVVIAM.TO 250/300 M18	STARTER ENGINE
3	26041	2		GRANO CENTRAGGIO D.7X8 F.5,2	DOWEL PIN 7 x 8 Hole 5,2
4	26256	2		BOCCOLA FLANGIATA BENDIX AVV. EL. 250/300 2T I.E.	BUSH
5	72400.23	1		LAMELLA MONO D.12 23-020	SHIM
6	68207	1		BENDIX MOTORE 250/300 2T ES MY 2019	BENDIX
7	05260	1		GUARN. COP. ACC. 250/300 2T ES M19->	GASKET, IGNITION COVER 250/300 2S ES MY 19
8	F15478	1		PICK-UP KOKUSAN	PICK-UP KOK PU5157
9	49601	2		RONDELLA 5X11	WASHER 5x11
10	49472	2		VITE TCEI 5X12	BOLT TCEI 5X12
11	49477	12		VITE TCEI 5X25 UNI 5931	BOLT TCEI 5X25
12	49615	3		RONDELLA ACCIAIO 5x11x0,5	WASHER STEEL 5 mm
13	15247	1		ROTORE X GEN. ES 250/300 2T IE CPL M.19-> in C45	ROTOR, INGNITION 250/300 2T ES MY 2019
13	F50816	1		ESTRATTORE ACC KOK 250/300 2T ES 19->	PULLER, ROTOR
14	F15551	1		STATORE KOK YS 9022	STATOR
15	15255	1		ACCENSIONE CPL 250/300 2T ES MY 2019 15247 + F15551	INGNITION 250/300 2T ES MY 2019
16	49613	1		RONDELLA ACCIAIO 12	STEEL WASHER 12
17	49056	1		DADO ACCENS 100/TAG/KZ 125MX/E	NUT, IGNITION 100cc
18	49580	2		VITE TCEI 4X10	BOLT
19	F30945	1		PROTEZIONE CAVI ACC.NE 250N	PROTECTION IGNITION WIRES 250N
20	30278	1		COPERCHIO ACCENSIONE 250/300 2T ES MY 19	COVER, INGNITION 250/300 2S MY 2019
21	F12322	1		O RING 2106	O-RING
22	49290	1		TAPPO COPERCHIO ACC. 250/300 2T MY 2019 (PUO' SOSTITUIRE F49833)	PLUG, ALUMINIUM

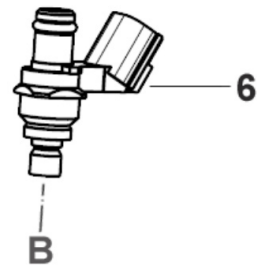
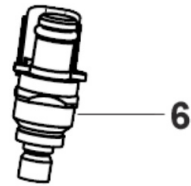
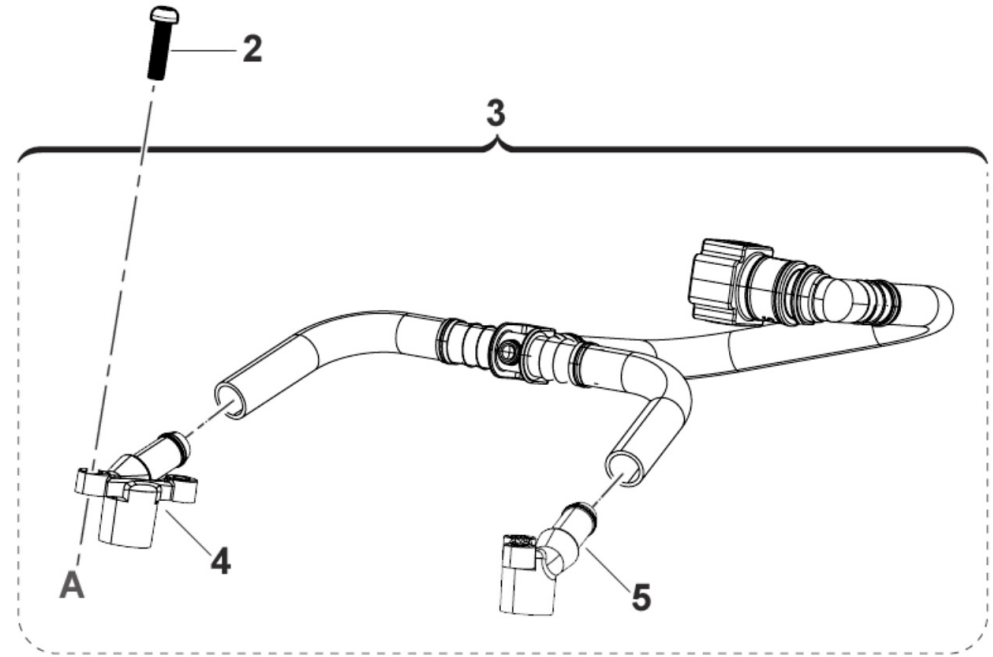
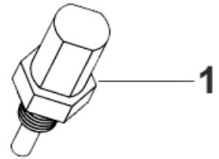
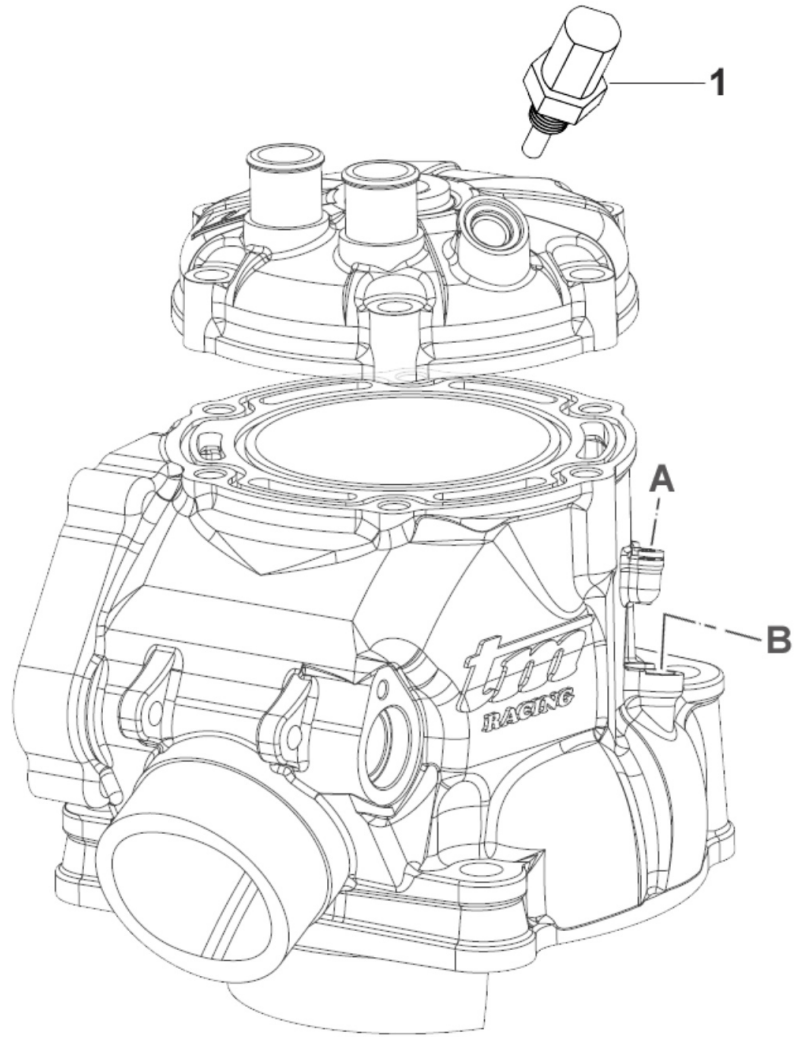



2T300FIEN20-M
MOTORE - ENGINE

SISTEMA INIEZIONE
INJECTION SYSTEM

11

Pos.	Codice	Q.tà	Note	Descrizione	Description
1	08014	1		SENSORE TEMP. ACQUA TESTA 250/300 2T F.I. 19	SENSOR, WATER TEMPERATURE
2	49557	4		VITE TBCE 4X16	BOLT TBCE 4x16
3	08006	1		Kit pre-assemblato Rail benz. CPL	CONDUIT ASSY
4	001067	1		FUS. CAPPuccio INIET. DX per 08003	JOINT RH
5	001077	1		FUS. CAPPuccio INIET. SX per 08004	JOINT LH
6	F08320	2		INJECTOR 330cc W/OUT D. (250/300 Fi 2T)	INJECTOR