



USES AND
RACOMMENDS



www.tmracing.it

TM Racing SpA - Via Fano, 6
61122 Pesaro - ITALY
Phone: +39 0721 25113

2T125MX24-M

MOTORE
ENGINE

11/12/2023



INFORMAZIONI GENERALI

Il presente catalogo serve per richiedere con esattezza le parti di ricambio.

Nelle ordinazioni indicare:

1) Il numero di matricola del Telaio che è stampigliato sul lato destro del canotto di sterzo. Nei modelli EN, SMR, SMR il numero di matricola è riportato anche su una targhetta posta sul lato sinistro (Vedi foto).

2) il numero di serie del Motore. E' posto sulla sinistra del motore tra la leva cambio e i coperchio accensione (Vedi foto).

3) Il codice dei particolari seguito dalla descrizione.

4) Il colore per i pezzi verniciati o comunque colorati.

Le indicazioni destra e sinistra si riferiscono ai lati del veicolo rispetto al senso di marcia.

Foto e disegni sono solo a scopo informativo e potrebbero non corrispondere esattamente alle caratteristiche dei prodotti.

GENERAL INFORMATION

The present spare parts catalogue enables one to order exactly the right spare part.

When ordering specify:

1) The frame serial number. It is embossed on the right side of the steering metal tube. In the EN, SMR and SMR models, the serial number is also stated on a plate positioned on the left hand side (See photo).

2) The engine serial numer. It is located on the left side of the engine between the gear lever and the ignition cover (See photo).

3) The part's code number followed but its description.

4) Indicate colour for painted or colored parts.

References to right and left apply to the vehicle in terms of its direction of movement.

Photos and drawings are for informational purposes only and may not exactly match the characteristics of the products.

NOTE – LEGENDA

MY

NOVITA' INTRODOTTA DIFFERENTE O NON PRESENTE NEL MODELLO DELL'ANNO PRECEDENTE

PART DIFFERENT OR NOT PRESENT IN THE REVIOUS YEAR MODEL

5M

MOTORE CON CAMBIO A 5 MARCE
ENGINE WITH 5 GEARS SPEED

6M

MOTORE CON CAMBIO A 6 MARCE
ENGINE WITH 6 GEARS SPEED

KS

MOTORE CON SOLO KICK STARTER
ENGINE WITH KICK STARTER ONLY

ES

MOTORE CON AVVIAMENTO ELETTRICO
ENGINE WITH ELECTRIC STARTER

X

RICAMBIO NON DISPONIBILE ALLA VENDITA
PART CAN NOT BE SOLD SEPARATELY

Le illustrazioni riportate in questo manuale sono fornite solo come riferimento e possono variare dal prodotto effettivo,

Dati indicativi soggetti a modifiche senza impegno di preavviso.

The illustrations in this manual are for reference only and may vary from the actual product.

All data are subject to modification without prior notice.

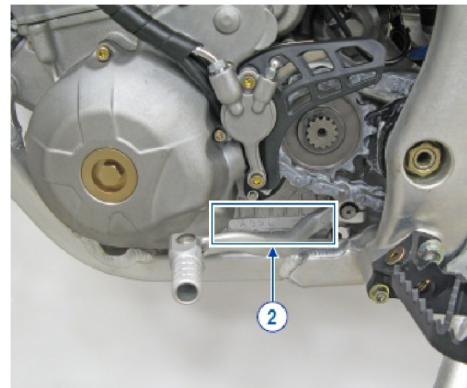
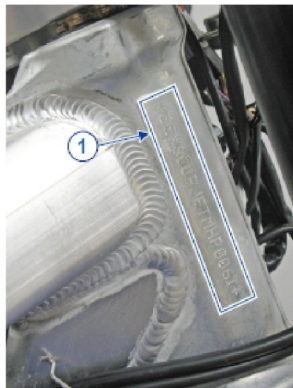



2T125MX24-M
MOTORE - ENGINE

CILINDRO - CYLINDER.....	4
MOTORINO VALVOLA - ELECTRIC VALVE SYSTEM.....	7
ALBERO MOTORE - PISTONE - CRANKSHAFT - PISTON.....	9
ACCENSIONE - IGNITION.....	11
BASAMENTO - CRANKCASE.....	13
FRIZIONE - CLUTCH.....	15
COPERCHI FRIZIONE E CENTRIFUGA.....	18
MESSA IN MOTO - KICK STARTER.....	20
COMANDO CAMBIO - GEARSHIFT MECHANISM.....	22
CAMBIO MX 6M.....	25
VITI COPERCHI.....	28
VITI BASAMENTO.....	30
-	32



2T125MX24-M
MOTORE - ENGINE

CILINDRO
CYLINDER

1

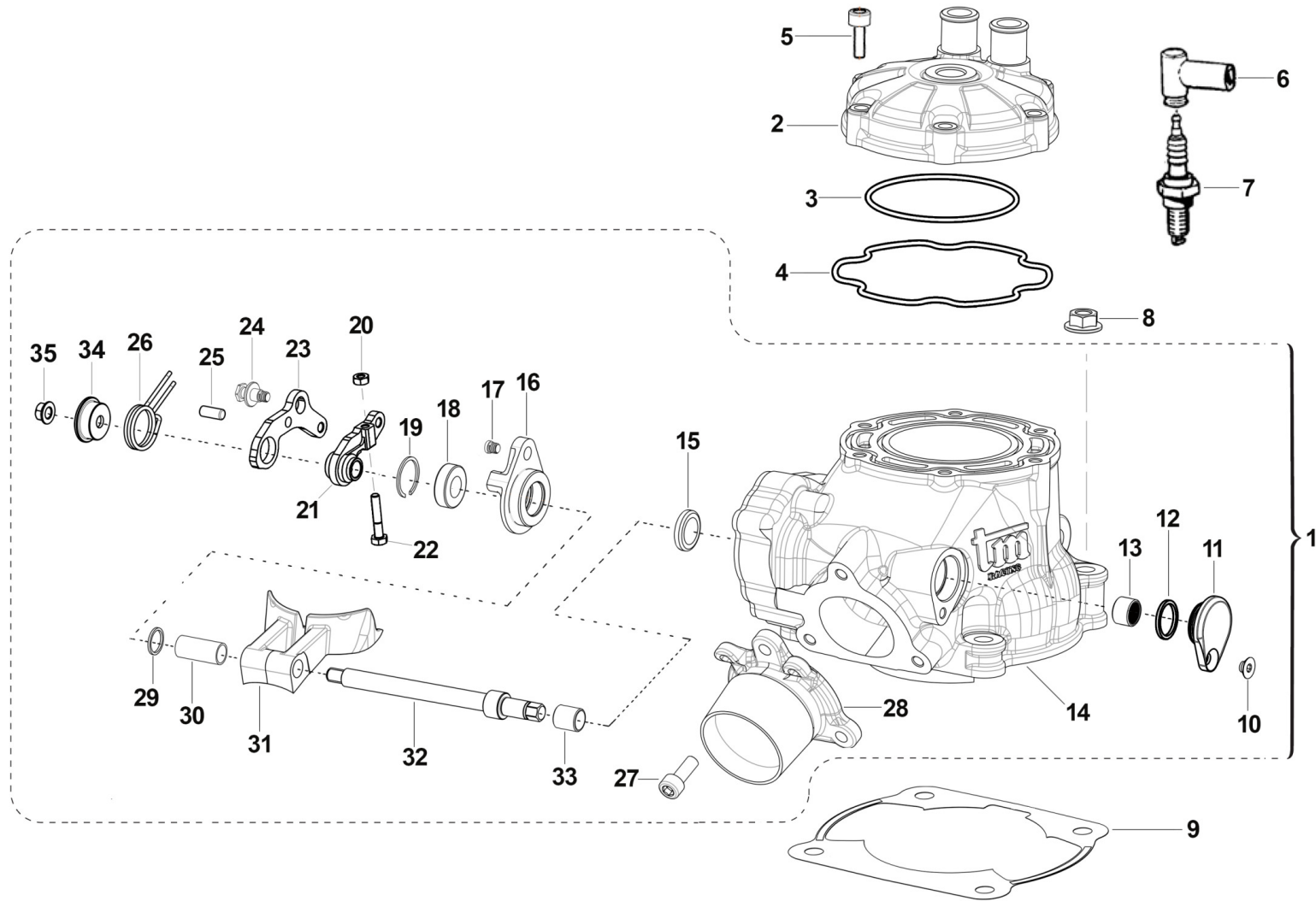



2T125MX24-M
MOTORE - ENGINE

CILINDRO
CYLINDER

1	01130	1		CILINDRO 125 2T MX MY20 CPL (CARB)	CYLINDER 125 2S MX MY20 ASSY
2	02024	1		TESTA 125 EV MX MOD. 2012	HEAD 125 MX MY 12
3	12003	1		O RING TESTA 125 90/06KVK8-910 NBR	O-RING, HEAD 125 90/06 KV8910
4	12021	1		O RING PREFORMATO CIL.125/12->	O-RING, HEAD 125EV M. 2012
5	49358	6		VITE TE F/R 6X30 Ch.8	BOLT 6X30 T.8
6	21017	1		PIPETTA CANDELA NGK LB05EMH	CAP, NGK SPARK PLUG LB05EMH
7	06011	1		CANDELA NGK BR9EG	SPARK PLUG, NGK BR9EG
8	49640	4		DADO M 8 FLANGIATO CHIAVE 12	NUT 8mm, FLANGE
9	05530	1		GUARN. B/CIL 125 M.2012 0,10	GASKET, CYL 125EV M.12/-> 0,10
9	05531	1		GUARN. B/CIL 125 M.2012 0,15	GASKET, CYL 125EV M.12/-> 0,15
9	05532	1		GUARN. B/CIL 125 M.2012 0,20	GASKET, CYL 125EV M.12/-> 0,20
9	05533	1		GUARN. B/CIL 125 M.2012 0,30	GASKET, CYL 125EV M.12/-> 0,30
9	05534	1		GUARN. B/CIL 125 M.2012 0,40	GASKET, CYL 125EV M.12/-> 0,40
9	05535	1		GUARN. B/CIL 125 M.2012 0,50	GASKET, CYL 125EV M.12/-> 0,50
10	49399	1		VITE TSEI 5X12	BOLT TSEI 5x12
11	30217	1		TAPPO SX ALB.COM.VALV.PAL.125	SIDE COVER
12	F12308	1		O RING 17,5 - 1,5	O-RING 17,5 - 1,5
13	19060	1		ASTUCCIO A RULLI HK 1212	NEEDLE CAGE HK 1212
14	01129	1	MY20	CILINDRO 125 2T MX M2020 NUDO	CYLINDER 125 2S MX MY20
15	04115	1		PARAOLIO G 12X18X3	OIL SEAL 12x18x3
16	26258	1	MY20	FLANGIA PORTACUSC. ALB.VALV.250/300 Fi 125/144 MY 20/24	FLANGE, BEARING HOLDER
17	49757	1		VITE TBCE 5 X 12	BOLT TBCE 5X12
18	03156	1		CUSCINETTO V.SC.C.12 698LLU/5K	BUSH, EXHAUST VALVE 698LLU
19	49220	1		SEEGER INT.19	SEEGER I 19
20	49630	1	MY20	DADO M 4 (BASSO)	NUT 4mm, LOW
21	28108	1	MY20	LEVA INTERNA COMANDO VALVOLE EES-2 125/144 2020	LEVER, INTERNAL, VALVE
22	49874	1	MY20	VITE TE 4X16	BOLT TE 4X16
23	28263	1	MY20	LEVA ESTERNA COMANDO VALVOLE EES-2	LEVER, EXTERNAL, VALVE



2T125MX24-M
MOTORE - ENGINE

CILINDRO
CYLINDER

1

24	26168	1	MY20	PERNO MOLLA EES-2 16066	PIN, SPRING
25	F19536	1	MY20	RULLO D. 5 X 12 M6 DIN 6325	PIN 5X12
26	16066	1	MY20	MOLLA EES-2	SPRING EES-2
27	49355	3		VITE TE F/R 6X16 Ch.8	BOLT 6X16 T.8
28	13081	1		COLLETTORE SCA. 125 12/-> 3F	MANIFOLD EXHAUST 125cc 12->
29	26130.12	1		SPESS. REG. CIL.125 2012 1.2	SPACER CYL. 125 ->12 1.2
29	26130.13	1		SPESS. REG. CIL.125 2012 1.3	SPACER CYL. 125 ->12 1.3
29	26130.14	1		SPESS. REG. CIL.125 2012 1.4	SPACER CYL. 125 ->12 1.4
29	26130.15	1		SPESS. REG. CIL.125 2012 1.5	SPACER CYL. 125 ->12 1.5
29	26130.16	1		SPESS. REG. CIL.125 2012 1.6	SPACER CYL. 125 ->12 1.6
29	26130.17	1		SPESS. REG. CIL.125 2012 1.7	SPACER CYL. 125 ->12 1.7
29	26130.18	1		SPESS. REG. CIL.125 2012 1.8	SPACER CYL. 125 ->12 1.8
29	26130.19	1		SPESS. REG. CIL.125 2012 1.9	SPACER CYL. 125 ->12 1.9
30	26147	1	MY20	BOCCOLA DIST. CIL. 250/300 2015 + 125 2020	BUSH
31	22065.15	1		VALVOLE SCARICO 125 EV M.15/22	VALVES EXHAUST 125 2S EV 15->
32	28059	1		ALBERO COMANDO PALETTE 125	SHAFT, BOOSTER 125
33	19061	1		BOCCOLA IR 8X12X12.5	BUSH, IR 1X12X12,5
34	26167	1	MY20	PIATTELLO GUIDA MOLLA EES-2 16066	COLLAR, SPRING
35	49676	1	MY20	DADO M 6X1 FLANG. AUTOBL.ACC.	NUT, FLANGED M6 X 1 S.B.



2T125MX24-M
MOTORE - ENGINE

MOTORINO VALVOLA
ELECTRIC VALVE SYSTEM

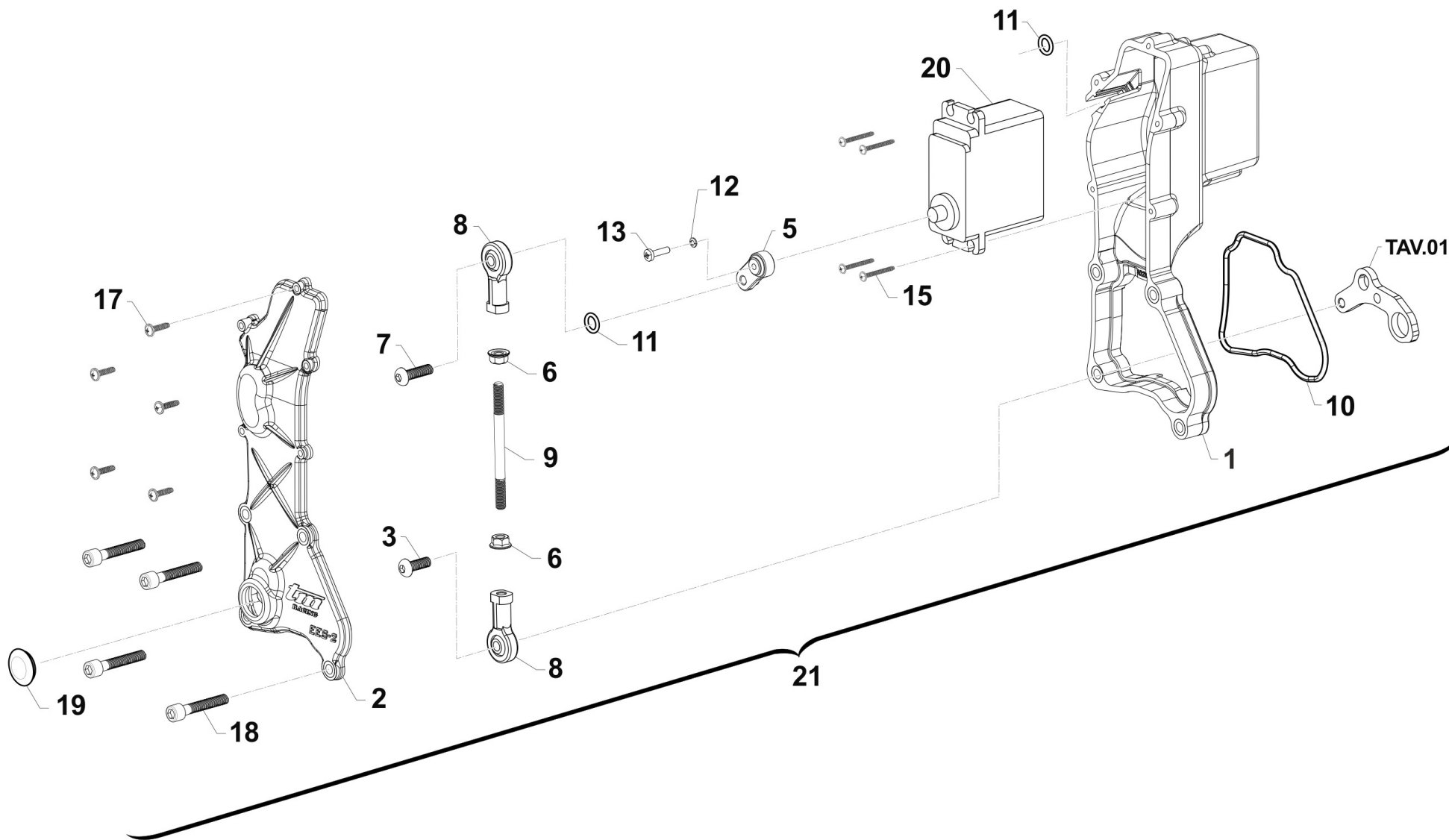

TM 0709



2T125MX24-M
MOTORE - ENGINE

MOTORINO VALVOLA
ELECTRIC VALVE SYSTEM

2

1	30291	1	CARTER EES-2 125/144 2T FI	CASE, PLASTIC, ENGINE VALVE
2	30392	1	COPERCHIO CARTER EES-2 125/144 2T FI	
3	49472	1	VITE TCEI 5X12 UNI 5931-912 Brun	BOLT TCEI 5X12
5	28266.0	1	LEVA SERVOMOTORE EES-2 DENTATURA 0	LEVER
5	28266.1	1	LEVA SERVOMOTORE EES-2 DENTATURA 1	LEVER
6	49632	2	DADO M 5 x 0,8 ZB	NUT 5mm
7	49929	1	VITE 10.9 TBCEI 5 x 18 UNI 7380	BOLT
8	72251	2	SNODO MECCANISCO VALVOLA EES-2 125/250/300	JOINT EXHAUST VALVE EES-2 250/300
9	28109	1	ASTINA COLLEGAMENTO UNIBALL EES-2 125/144 2020	ROD, UNIBALL 125/144 MY20
10	12042	1	O RING COP. VALVOLA EES-2	O-RING
11	F12301	2	O RING 106 4T PIOGGIA CAMBIO	O-RING, 106 GEAR F.S.
12	49124	1	RONDELLA SCHNORR ZIG. 2.5	
13	49881	1	VITE T.C. 2,5X12	
15	49973	4	VITE STS-Plus KN6031 2.2X20 PLASTICA	BOLT
17	490021	5	VITE TCBL 3.0X 16 FL. X PLAST.	
18	49478	4	VITE TCEI 5X30 UNI 5931	BOLT TCEI 5X30
19	21009	1	TAPPO GOMMA COPERCHIO VALV.SC.	RUBBER, COVER
20	22500	1	SERVOMOTORE VALV.SCARICO HITEC	EL. ENGINE EXHAUST VALVE HITEC
21	22502.20	1	SERVOMOTORE V/SC. CPL 125/144 MY20	EL. ENGINE EXHAUST, 125/144 MY20 ASSY

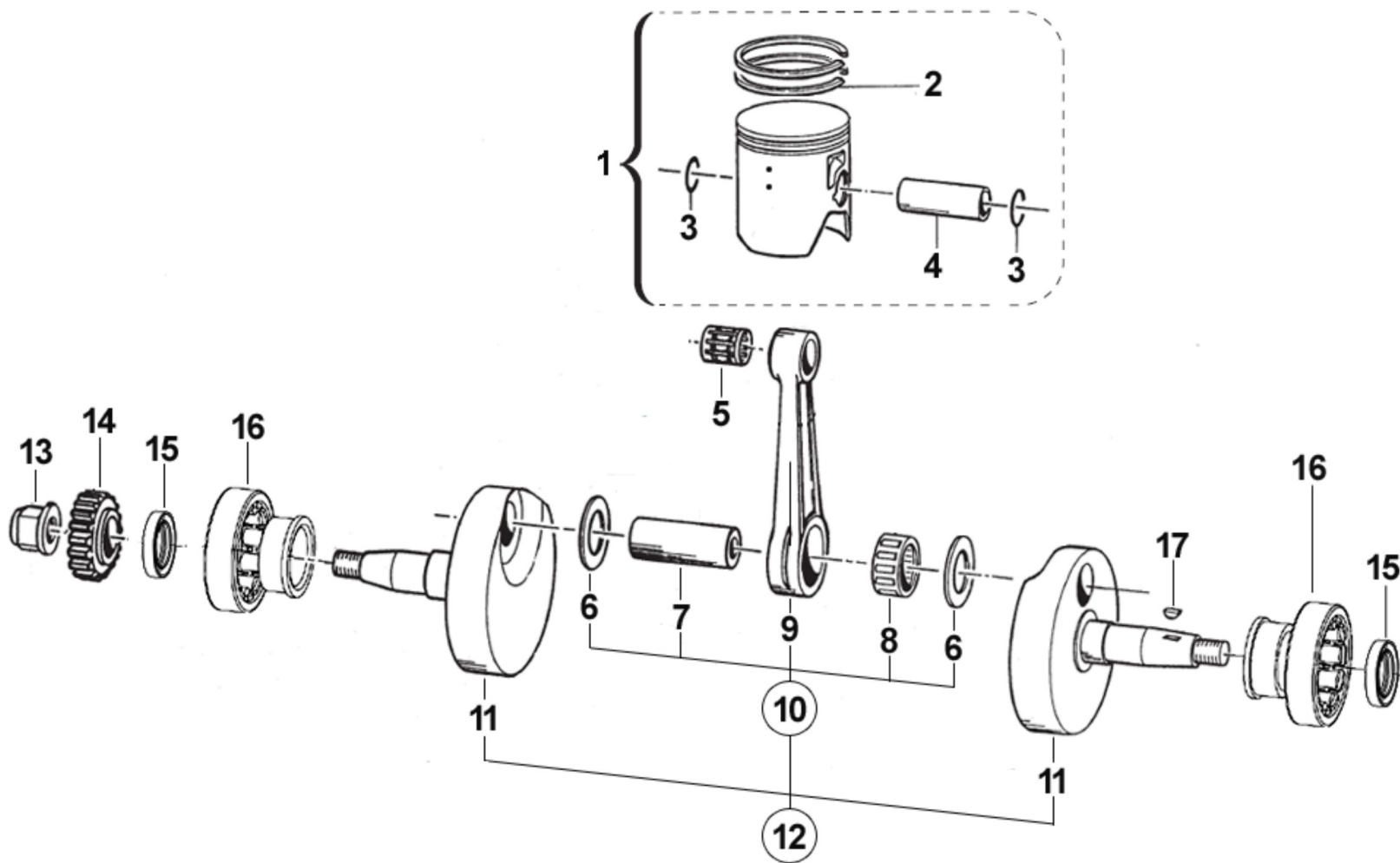



2T125MX24-M
MOTORE - ENGINE

ALBERO MOTORE - PISTONE
CRANKSHAFT - PISTON

3

1	10022.94	1	PISTONE 53.94 125 2014 2F(0,8)	PISTON 53.94 125CC M14 2 R.0,8
1	10022.95	1	PISTONE 53.95 125 2014 2F(0,8)	PISTON 53.95 125CC M14 2 R.0,8
1	10022.96	1	PISTONE 53.96 125 2014 2F(0,8)	PISTON 53.96 125 M.14-> 2R.0,8
1	10022.97	1	PISTONE 53.97 125 2014 2F(0,8)	PISTON 53.97 125 M.14-> 2R 0,8
1	10022.98	1	PISTONE 53.98 125 2014 2F(0,8)	PISTON 53.98 125 M.14-> 2R 0,8
2	11069	2	SEGMENTO 54,00 X 0,80 TPR	PISTON RING 54,00 X 0,80 TPR
3	09004.1	2	ANELLINO SPINOTTO 15 x 1 PIST.125/144	CLIP, PISTON PIN 125 / 144
4	09008	1	SPINOTTO PISTONE 125 15X41F10	PIN, PISTON 125, 15x41 F10
5	19034	1	GABBIA SPINOTTO 15X19X17,3	TOP END B. 15X19X17,3
6	18239	2	RONDELLA ARGENTATA D.22 X 1 v2	WASHER, SILVER ID 22 X 1
7	18091.4	1	ASSE ACCOP. 22 X 50.4 F.5	CRANKPIN 22 X 50,4 hole 5mm
8	17015	1	GABBIA ARGENTATA 222815	SILVER CAGE 22X28X15
9	18053.2	1	BIELLA ASSE 22 FORG. NUDA 109,8	CONROD D.22mm FORGED 109,8
10	18125.2	1	BIELLA 125Fi ASSE 22 x 50,4 CPL ASSE F.5	CONROD ASSY KZ10-B 22 PIN H.5
11	18241	1	COPPIA SEMIALBERI 125 MX/E '15	CRANKSHAFT SIDES
12	18242	1	ALBERO MOTORE 125 EV MX/E 15/-	CRANKSHAFT 125 EV MX/E M.15->
13	49094	1	DADO TRASMISS.125 06 M 14 X 1.25	NUT,CLUTCH CENT.14X1.25 125 06
14	40303	1	PIGNONE COPPIA PRIMARIA Z19 CR	PRIMARY DRIVE GEAR 19T MX
14	50030	1	ESTRATTORE PIGNONE COPPIA	PRIMARY GEAR PULLEY
15	04035	2	PARAOLIO 20x30x7 PTFE	OIL SEAL 20 x 30 x 7 PTFE
16	03029	2	CUSCINETTO BC1-1442 B	BUSH, BC1-1442 B KZ10
17	49010	1	CHIAVETTA VOLANO 13x5x3	WOODRUFF KEY



2T125MX24-M
MOTORE - ENGINE

ACCENSIONE
IGNITION

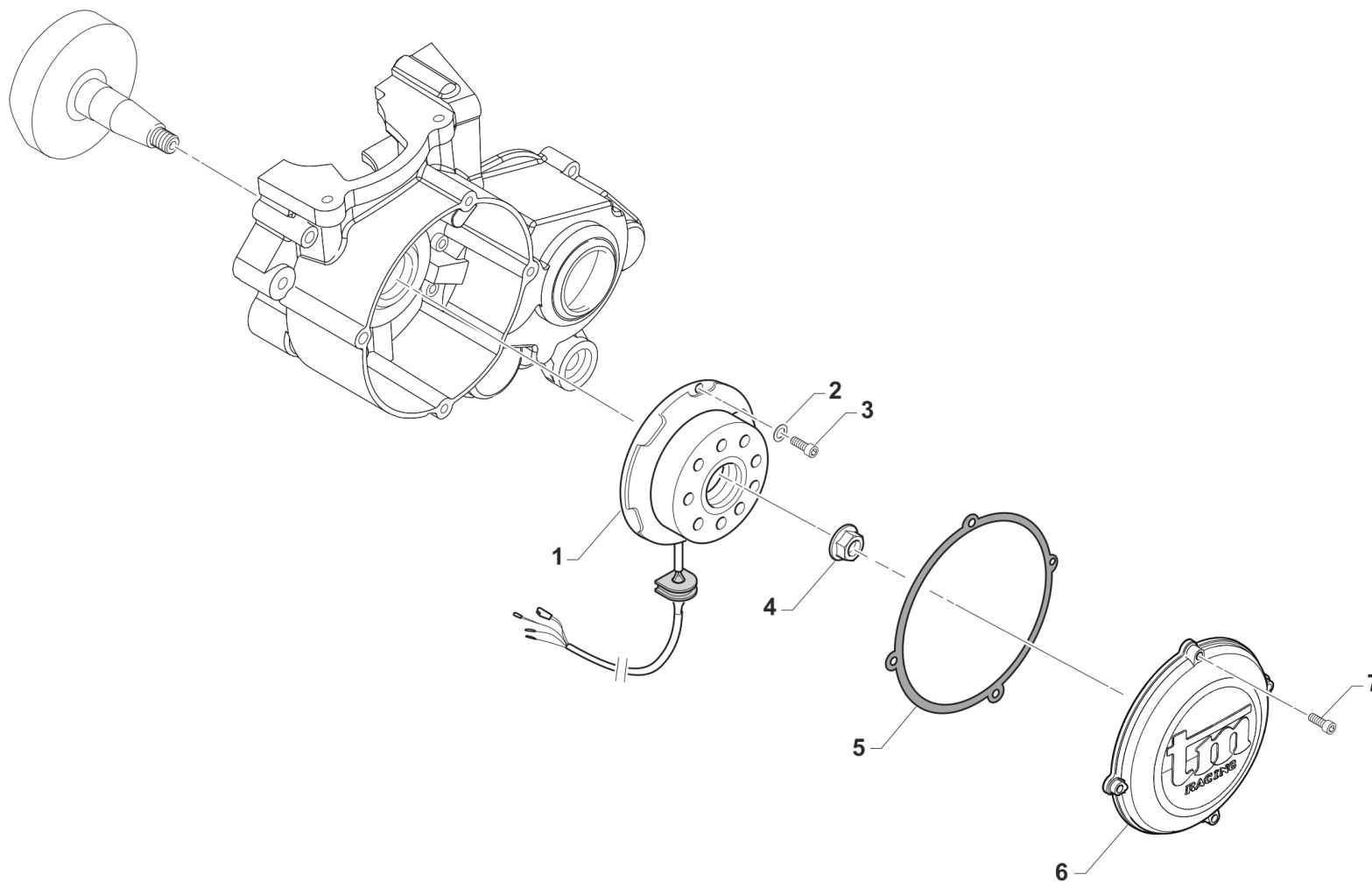

TM 0178.02



2T125MX24-M
MOTORE - ENGINE

ACCENSIONE
IGNITION

1	15230	1	GENERATORE KOK END 11 MX/E 12	GENERATOR KOK END 11 MX/E 12->
2	49603	2	RONDELLA M 6,4 X 12 X 1,6	WASHER 6x12
3	49484	2	VITE TCEI 6X20	BOLT TCEI 6X20
4	49056	1	DADO ACCENS 100/TAG/KZ 125MX/E	NUT, IGNITION 100cc
5	05516	1	GUARN. COP.ACC. 80/125 KOKUSAN	GASKET, KOK.IGNIT.COV. 80/125
6	30211	1	COP. ACC. MX 125/144 06/11 E11	COVER, IGNITION MX 80/125 2006 KOK.
7	49477	4	VITE TCEI 5X25 UNI 5931-912	BOLT TCEI 5X25



2T125MX24-M
MOTORE - ENGINE

BASAMENTO
CRANKCASE

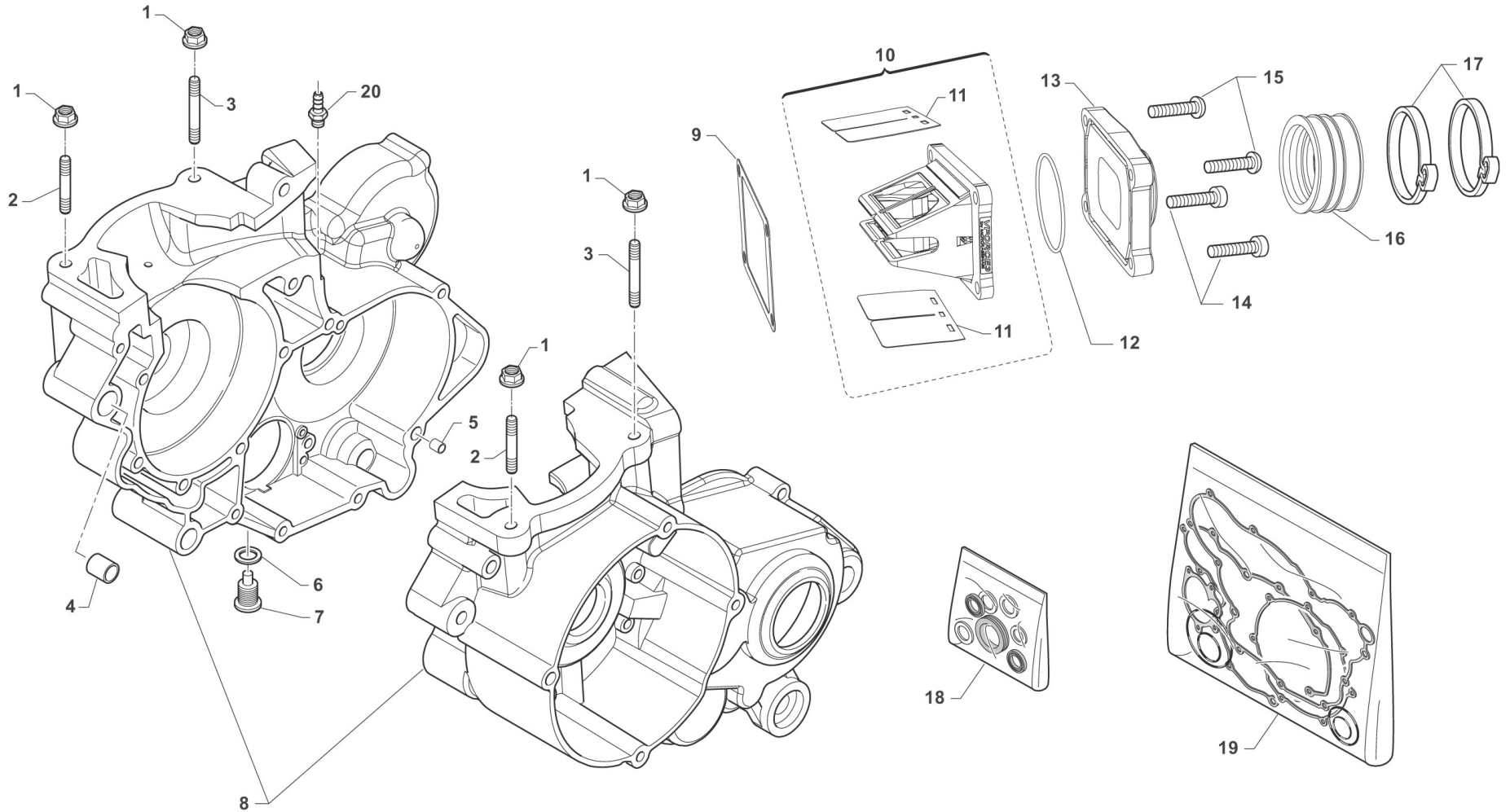

TM125FI20-M-06



2T125MX24-M
MOTORE - ENGINE

BASAMENTO
CRANKCASE

1	49640	4	DADO M 8 FLANGIATO CHIAVE 12	NUT 8mm, FLANGE
2	49020	2	PRIGIONIERO CIL.48 mm 80/125	STUD CYL.48mm 80/125cc
3	49027	2	PRIGIONIERO CIL.58 KV-K7-K8-K9	STUD 8 X 58 mm
4	26043	1	GRANO CARTER ANT. 14 X 14	GRUB SCREW 14X14
5	26044	1	GRANO CENTRAGGIO MOTOR.10X13,6	GRUB SCREW 10X13,6
6	49103	1	RONDELLA 14X20X1,5 ALLUMINIO	WASHER, 14 X 20 X 1.5 ALUMINUM
7	49301	1	TAPPO OLIO C/CALAM. 2T	OIL PLUG WITH MAGNET
8	30176.15	1	BASAMENTO MOTORE 125 EV 2015	CRANKCASE, 125
9	05277	1	GUARN. PACCO LAMELLE VFORCE 3	GASKET, REED BLOCK VFORCE 3
10	20061	1	PACCO LAM 125/144 VF3 M. 08/->	REEDS BOX VF3 125/144 M. 08/->
11	20074	1	LAMELLE V-FORCE3 125/144 07/->	REEDS, V-FORCE3 125/144 07/->
12	12026	1	O RING CONVOGLIATORE 125 13086	O-RING INLET MANIFOLD 125 13086
13	13086	1	COLLETTORE AI ASP. 125cc 2013	ALL. INTAKE MANIFOLD 125 cc M.13->
14	49484	2	VITE TCEI 6X20	BOLT TCEI 6X20
15	49484	2	VITE TCEI 6X20	BOLT TCEI 6X20
16	13009	1	MANICOTTO COLLETTORE ASP.97/14	MANIFOLD RUBBER,INTAKE M.97/14
17	51054	2	FASCETTA SM9 D.52	CLAMP SM9 D.52mm
18	04034.15	1	KIT PARAOLI 125 EV M.2015	OIL SEALS 125cc EV M.15->
19	05621	1	KIT GUARN. + OR 125 2012 V.EL	GASKETS + OR 125cc M.12->
20	49009	1	RACCORDO SFIATO OLIO MX/E F.4	JOINT, OIL BREATHER

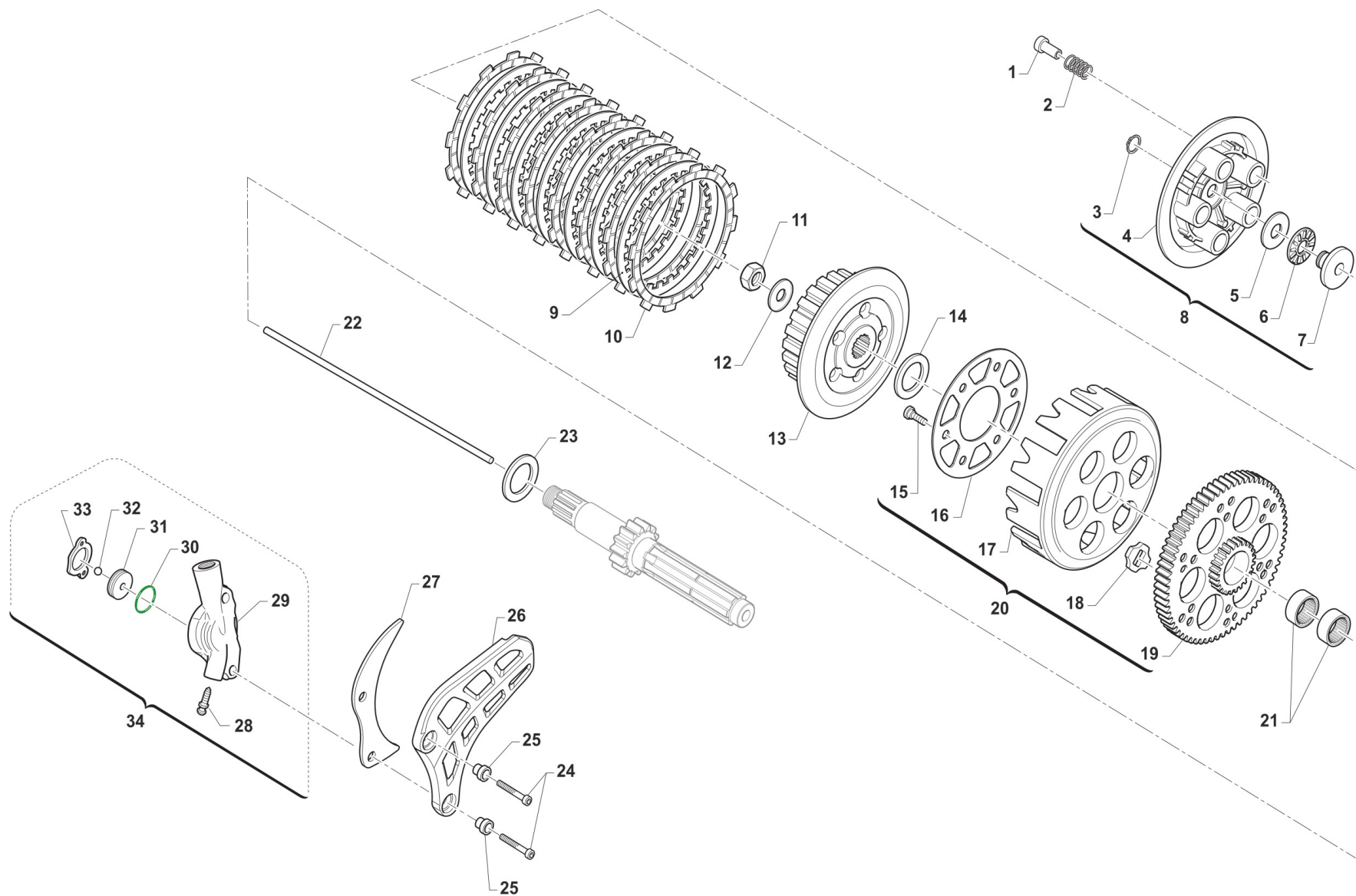

TM0174



2T125MX24-M
MOTORE - ENGINE

FRIZIONE
CLUTCH

1	49057	5	DADO FRIZIONE ERGAL 125/144	NUT, CLUTCH KZ10 ERGAL
2	16020	5	MOLLA FRIZIONE 125 C/E 03/08BA	SPRING, CLUTCH 125 MX/E 03/->
3	49211	1	SEEGER E10x1 ANELLO PIATT.REG.	CIRCLIP D.8,4 - EXTERNAL
4	35015	1	PIATTO SPINGIDISCO FRIZIONE 125 97->	PLATE, CLUTCH PRESS.125 97/02
5	19021	1	RONDELLA X GABBIA RULLI AS1024	WASHER, NEEDLE CAGE AS 1024
6	19020	1	GABBIA A RULLI RAD. AXK 1024	NEEDLE CAGE AXK 1024, RADIAL
7	26001	1	REGGISPINTA FRIZIONE	CLUTCH THRUST
8	35025	1	PIATTO SPING.FRIZ 125/KART CPL	PLATE, CLUTCH PRESSURE ASSY
9	35019	7	DISCO FRIZ. ACC. 1mm 99/05	CLUTCH PLATE, STEEL 1mm 99/05
10	35012	8	DISCO FRIZ. GUARN.CR/E M.93->	CLUTCH PLATE, FIBER 85/125 MX/E 93/->
11	49052	1	DADO TAMBURELLO FRIZIONE	NUT, CLUTCH CENTER
12	49127	1	MOLLA A TAZZA DIN 2093 28X14,2X1,25	DISC SPRING DIN 2093 28x14,2x1,25
13	25099.14	1	TAMBURELLO FRIZIONE 125 2014	CLUTCH CENTRE 125cc M.14->
13	50124	1	CHIAVE FRIZ. 85/125 + KART CPL	CLUTCH TOOL 85/125cc + KART
14	48002	1	SPESSORE COP.PRIM.30X18X3	SPACER 30x18x3
15	49727	6	VITE PARASTRAPPI K9 M7X1X12.5	SCREW, M7X1X12,5 K9 ENGINE
16	35026	1	DISCO BATTUTA GOMM. FRIZ.KZ10B 85/125	DISC STOP RUBBERS CLUTCH KZ10B
17	25000	1	CAMPANA FRIZ.125 M.91/96 99/23	CLUTCH BASKET 125 91/96 99/05
18	21005	6	GOMMINO PARASTRAPPI FRIZIONE	RUBBER, CLUTCH BASKET
19	40402	1	COPPIA PRIM. 125 Z63	PRIMARY GEAR 63T, 125cc
20	40409	1	COPPIA PRIM. 125 Z63 CPL 99/-> 93/96	PRIM.GEAR 63T,125 Comp. 99/04
21	19013	2	GABBIA A RULLI K 20X24X12	NEEDLE CAGE 20 X 24 X 12
22	35043	1	ASTINA FRIZ. IDR. 125 M.99/10	ROD, HYDR.CLUTCH 125 M. 99/04
23	48003	1	SPESSORE COP.PRIM.30X20X2	SPACER 30X20X2 PRIMARY GEAR
24	49486	2	VITE TCEI 6X30 UNI 5931	BOLT TCEI 6X30
25	26212	2	BOCCOLA PROT. PIGNONE 125 F.6	COLLAR, SPROCKET 125cc H.6
26	40029	1	PROTEZIONE PIGNONE 09/-> PLAST	PROTECTION FRONT SPROCKET09/13
27	40022	1	PROTEZIONE ERGAL PIGNONE CAT.	PROTECTION, GEAR CHAIN ERGAL



2T125MX24-M
MOTORE - ENGINE

FRIZIONE
CLUTCH

28	35264	1	VITE SPURGO OLIO FRIZ.IDR.6X1	SCREW AIR BLED HYDRAUL.CLUTCH
29	30205	1	COP. FRIZ/IDR 80/125 95/11 NUD	OUTPUT H.CLUTCH CYLINDER
30	12259	1	O RING PISTONE FR.125/250 VITON (Verde)	O-RING, CLUTCH PISTON 125/250
31	35125	1	PISTONE POMPA FRIZ. 125 95/->	PISTON, CLUTCH PUMP 125 95/04
32	19052	1	SFERA 8 X FRIZIONE 250 5/16"	BALL, IDR. CLUTCH PUMP
33	05509	1	GUARN. POMPA FRIZ.IDR. 80/125	GASKET, HYDRAULIC CLUTCH80/125
34	30206	1	COP. FRIZ/IDR 85/125 95/-> CPL	OUTPUT H.CLUTCH CYLINDER CPL.

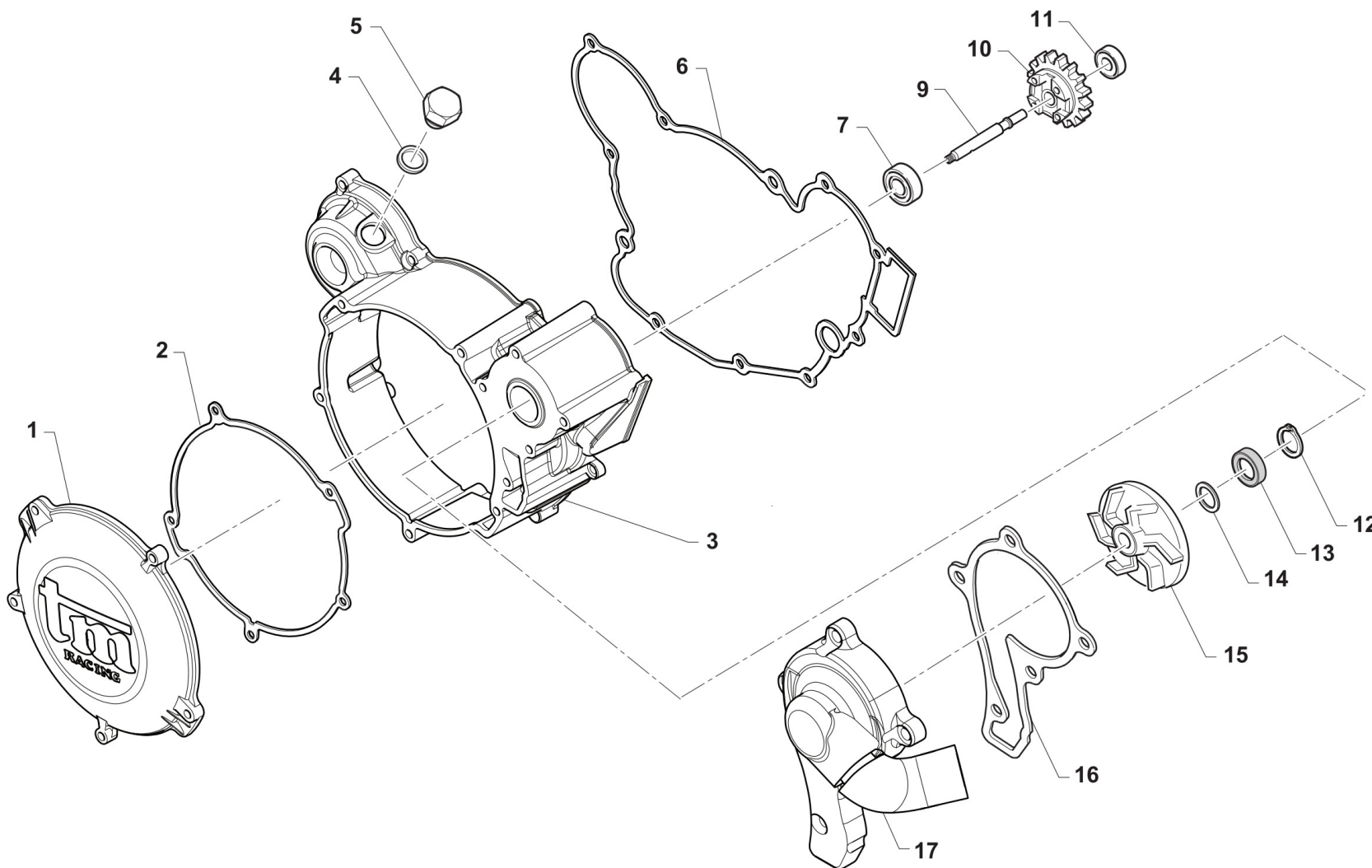



2T125MX24-M
MOTORE - ENGINE

COPERCHI FRIZIONE E CENTRIFUGA

1	30187	1	COPERCHIETTO FRIZ. 125 M.2006	COVER, CLUTCH, EXT. 125 06/->
2	05526	1	GUARN. COP.FRIZ. EST.125 06/->	GASKET, EXT.CLUTCH COVER 125/6
3	30174	1	CARTER FRIZIONE 125 M.12/->	CLUTCH COVER 125 M.12->
4	49103	1	RONDELLA 14X20X1,5 ALLUMINIO	WASHER, 14 X 20 X 1.5 ALUMINUM
5	49300	1	TAPPO CARICO OLIO	OIL PLUG, FILL
6	05527	1	GUARN. COP.FRIZ. INT.125 06/->	GASKET, CLUTCH CASE 125 06/->
7	03014	1	CUSCINETTO 608 ZC3 POMPA SCHER	BUSH, WATER PUMP 608 Z C3
9	28062	1	ALBERINO POMPA ACQUA 125 2012	SHAFT, WATERPUMP 125 M.12/->
10	40071	1	INGR COMANDO POMPA H2O 125 '12	GEAR, WATERPUMP 125 M.12/->
11	03025	1	CUSCINETTO 626 C3 POMPA H2O 06	BUSH, WATER PUMP 626 C3
12	49215	1	SEEGER I22 POMPA ACQUA	CIRCLIP D.22 WATER PUMP
13	04017	1	PARAOLIO CENTRIFUGA 06	OIL SEAL 8 X 22 X 7 TC
14	49689	1	RONDELLA 6 X 12 SP. 1.2	WASHER 6x12 sp. 1,2
15	28009	1	GIRANTE POMPA ACQUA 2006/08	IMPELLER, WATER PUMP M.06/->
16	05528	1	GUARN. POMPA ACQUA 125 2006	GASKET WATER PUMP 125cc 2006
17	30194.20	1	COPERCHIO POMPA H2O 125/144 maggiorato	



2T125MX24-M
MOTORE - ENGINE

MESSA IN MOTO
KICK STARTER

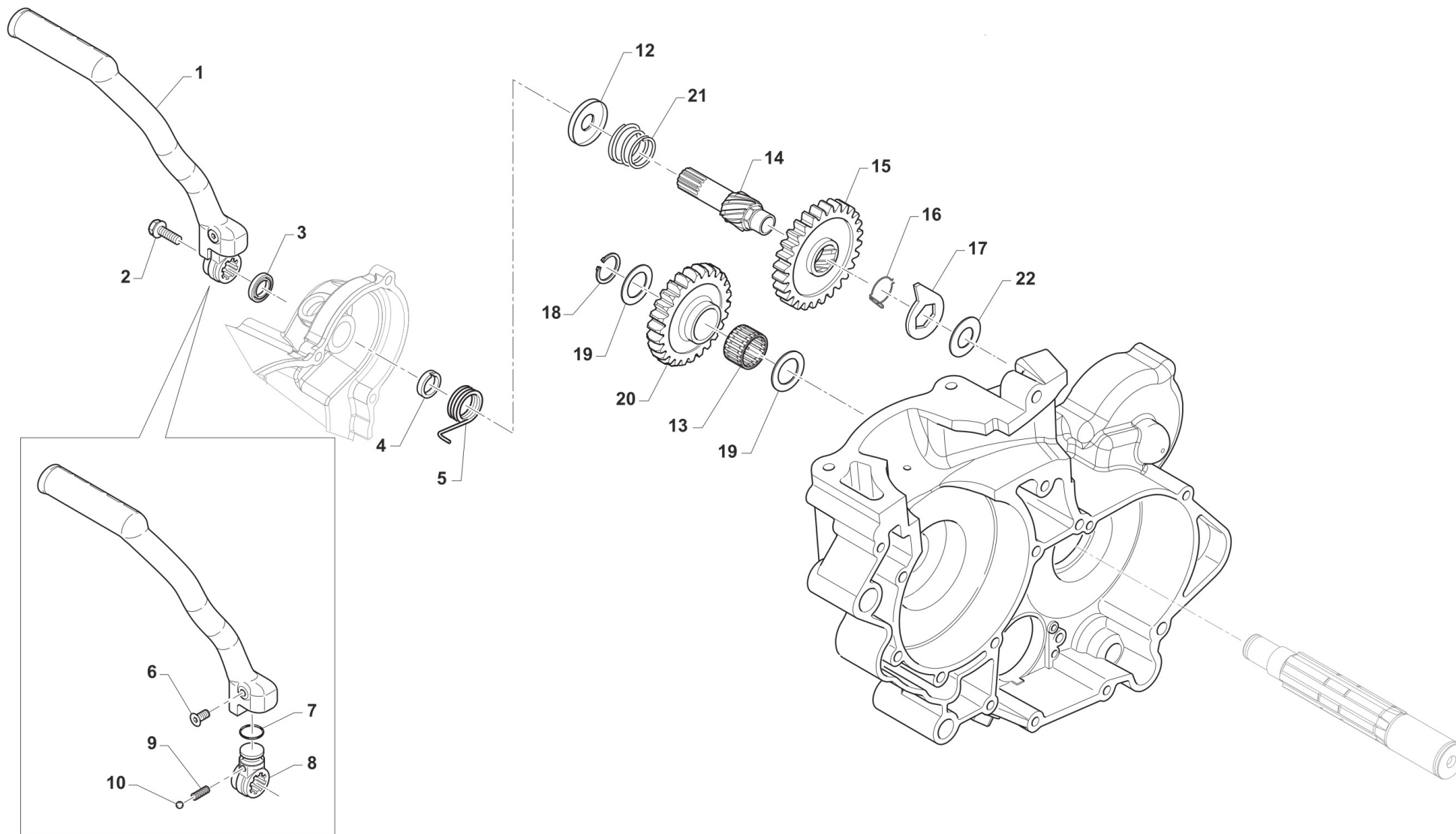

TM 0183



2T125MX24-M
MOTORE - ENGINE

MESSA IN MOTO
KICK STARTER

1	43038	1	LEVA M/M 80/125 M. 99/->	LEVER, KICK STARTER 125 99/->
2	49368	1	VITE TE F/R 6X10 LEVA M/M	BOLT 6X10 (Kich Starter)
3	04005	1	PARAOLIO ALBERINO M/M 15x24x7	OIL SEAL 15 x 24 x 7
4	26005	1	DISTANZIALE MOLLA M/M	SPACER, KICK STARTER SPRING
5	16008	1	MOLLA M/M 80 / 125 / 144 cc	SPRING, KICK STARTER
6	49406	1	VITE TSEI 6X20	BOLT TSEI 6x20
7	12260	1	O RING INTERNO LEVA M/M 250	O-RING INT.LEVER KICK START250
8	43039.01	1	MOZZETTO KICK START 125 M. 96 ->	
9	16039	1	MOLLA X SFERA LEVA M/M 250 CC	SPRING, BALL KICK-START. 250cc
10	43250.03	1	SFERA 1/4C X LEVA M/M 250 CC	BALL, KICK STARTER LEVER 250cc
12	26188	1	PIATTELLO MOLLA CONTRASTO M/M 125	
13	19010	1	GABBIA A RULLI K 15X19X10	BUSH NEEDLE CAGE 15 X 19 X 10
14	28051	1	ALBERO MESSA IN MOTO 125/144 96/18	SHAFT, KICK STARTER 125 96/05
15	40350	1	INGRANAGGIO SCORREVOLE M/M 125 / 144	SLIDING GEAR, KICK STARTER 125
16	16006	1	MOLLA X INGRANAGGIO M/M	SPRING, KICKSTART SLIDING GEAR
17	26254	1	LEVA BATTUTA M/M 125/250 96/->	STOPPER, KICK STARTER
18	49214	1	SEEGER E15 INGRANAGGIO M/M	CIRCLIP GEAR K.S. 15mm
19	48004	2	SPESSORE INGRANAGGIO M/M	SPACER, K.STARTER GEAR
20	40351	1	INGRANAGGIO LIBERO M/M 125 / 144	GEAR, KICK STARTER 125
21	F16416	1	MOLLA DI CONTRASTO M/M 4T	SPRING K.STARTER 4S
22	F48354	1	SPESSORE TT 14 X 30 X 0,5	SPACER



2T125MX24-M
MOTORE - ENGINE

COMANDO CAMBIO
GEARSHIFT MECHANISM

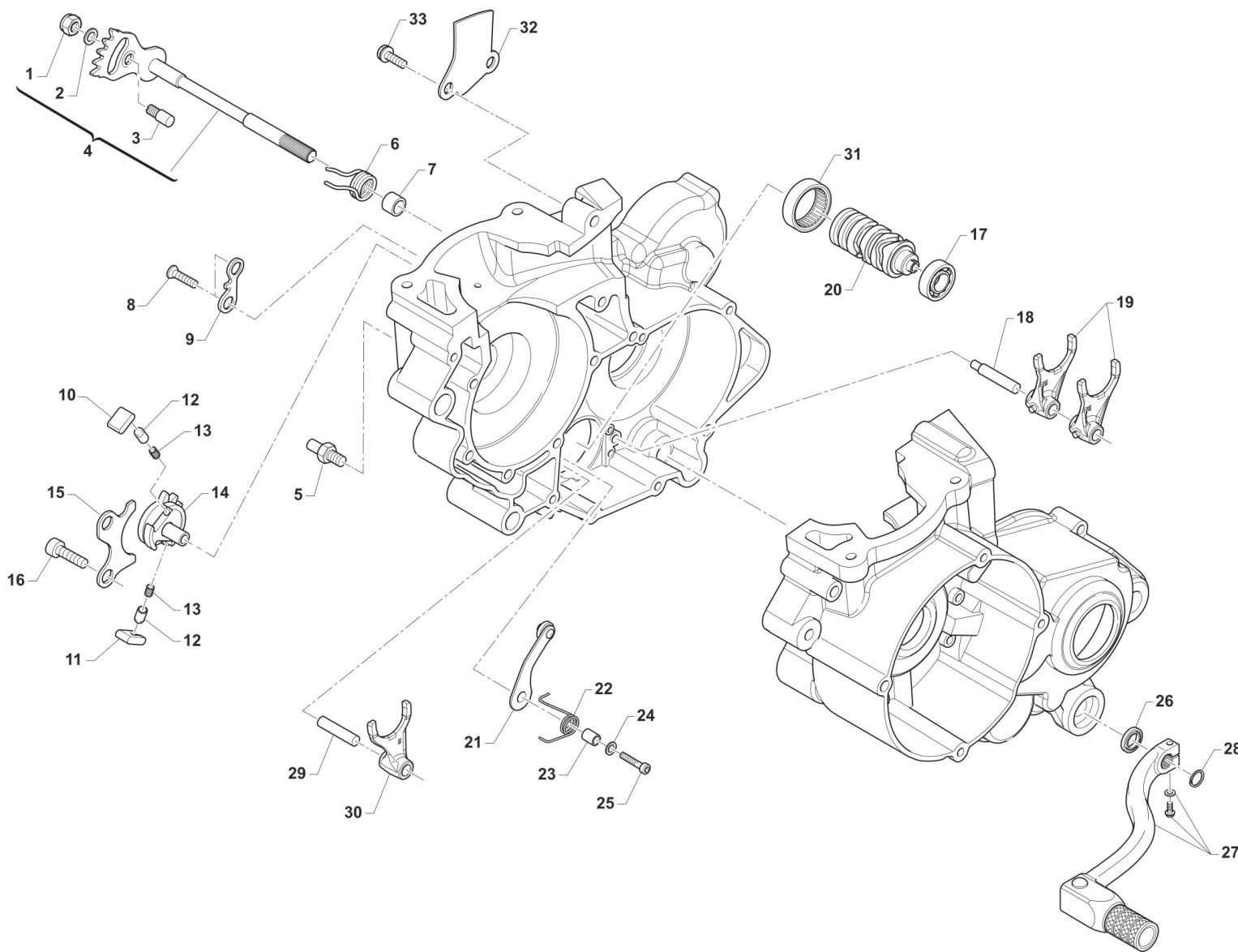

0702



2T125MX24-M
MOTORE - ENGINE

COMANDO CAMBIO
GEARSHIFT MECHANISM

1	49638	1	DADO M 6 ALTO AUTOBLOCCANTE	NUT 6mm, HIGHT SELF-LOCKING
2	49603	1	RONDELLA M 6,4 X 12 X 1,6	WASHER 6x12
3	26050	1	BATTUTA ECCENTRICA	ADJUSTER SELECTOR SHAFT
4	28100	1	ALBERO COMANDO ING. P.TACRIC.	SHAFT, GEARSHIFT
5	26051	1	BATTUTA FISSA LEVA CAMBIO INT.	PLATE INT. END STROKE GEAR LEVER
6	16009	1	MOLLA RITORNO LEVA CAMBIO 32CR	SPRING, RETURN GEAR LEVER 3,2
7	26006	1	DISTANZIALE MOLLA LEVA CAMBIO	SPACER, GEAR LEVER SPRING
8	49405	2	VITE TSEI 6X20 UMB.5933 10.9	BOLT TSEI 6x20 U.5933 10.9
9	26022	1	PIASTRINO FINE CORSA	PLATE END STROKE GEAR LEVER
10	26060	1	CRICCHETTO CAMBIO SUPERIORE	RATCHET UP, GEAR
11	26061	1	CRICCHETTO CAMBIO INFERIORE	RATCHET DOWN, GEAR
12	26062	2	PUNTALE PER CRICCHETTO CAMBIO	PIN, RATCHET GEAR
13	16012	2	MOLLA PER PUNTALE	SPRING, GEARBOX PIN
14	40310	1	INGRANAGGIO PORTACRICCHETTI	DRUM SHIFTER GEAR
15	26021	1	PIASTRINO RIENTRO CRICCHETTI	PLATE, RATCHET
16	49483	2	VITE TCEI 6X16 UNI 5931	BOLT TCEI 6X16
17	03012	1	CUSCINETTO DESMODROMICO 6001 2RS	BUSH, 6001 2RS GEAR DRUM
18	33256	1	PERNO FORCH.ALB.SEC. 250 / 125.99	AXEL, COUNTERSHAFT FORK 250cc
19	F33314	2	FORCHETTA A/S 125/250/300 CROM	SHIFT FORK SECONDARY 125/250CR
20	33004	1	ALBERO DESM.125 INTEGR. 6M CPL 125/144 6 M. CPL DI F26476	GEAR DRUM 125 6SP. 125/144 ASSY F26476
21	26063.12	1	PIASTRINO BLOCCAMARCE 2012 CPL	PLATE STOP GEAR ASSY M.12->
22	16252	1	MOLLA BLOCCAMARCE 125 / 250 2T	
23	26007	1	DISTANZIALE MOLLA BLOCCAMARCE	SPACER, STOP GEAR SPRING
25	49485	1	VITE TCEI 6X25 UNI 5931	BOLT TCEI 6x25
26	04004	1	PARAOLIO POMPA H2O-LEVA CAMBIO	OIL SEAL 12 x 22 x 5
27	43048	1	LEVA CAMBIO 2014 + 12MM (253) 85/125/144 2T 250Fi	GEAR LEVER 2014 +12mm
28	49212	1	SEEGER E12 LEVA CAMBIO	CIRCLIP D.12 - EXTERNAL
29	33255	1	PERNO FORCH.ALB. PRIM.250 / 125.99	AXEL, MAINSHAFT FORK 250cc



2T125MX24-M
MOTORE - ENGINE

COMANDO CAMBIO
GEARSHIFT MECHANISM

30	33016	1	FORCHETTA ALB.PRIM.125 PRT.CRM	SHIFT FORK MAINSHAFT 125 CROM.
31	19041	1	ASTUCCIO A RULLI DHK 35/12	BUSH NEEDLE CAGE DHK 35/12
32	26023	1	PIASTRINO CONVOGLIATORE OLIO	PLATE, OIL
33	49440	2	VITE TE 6X14	BOLT TE 6X14

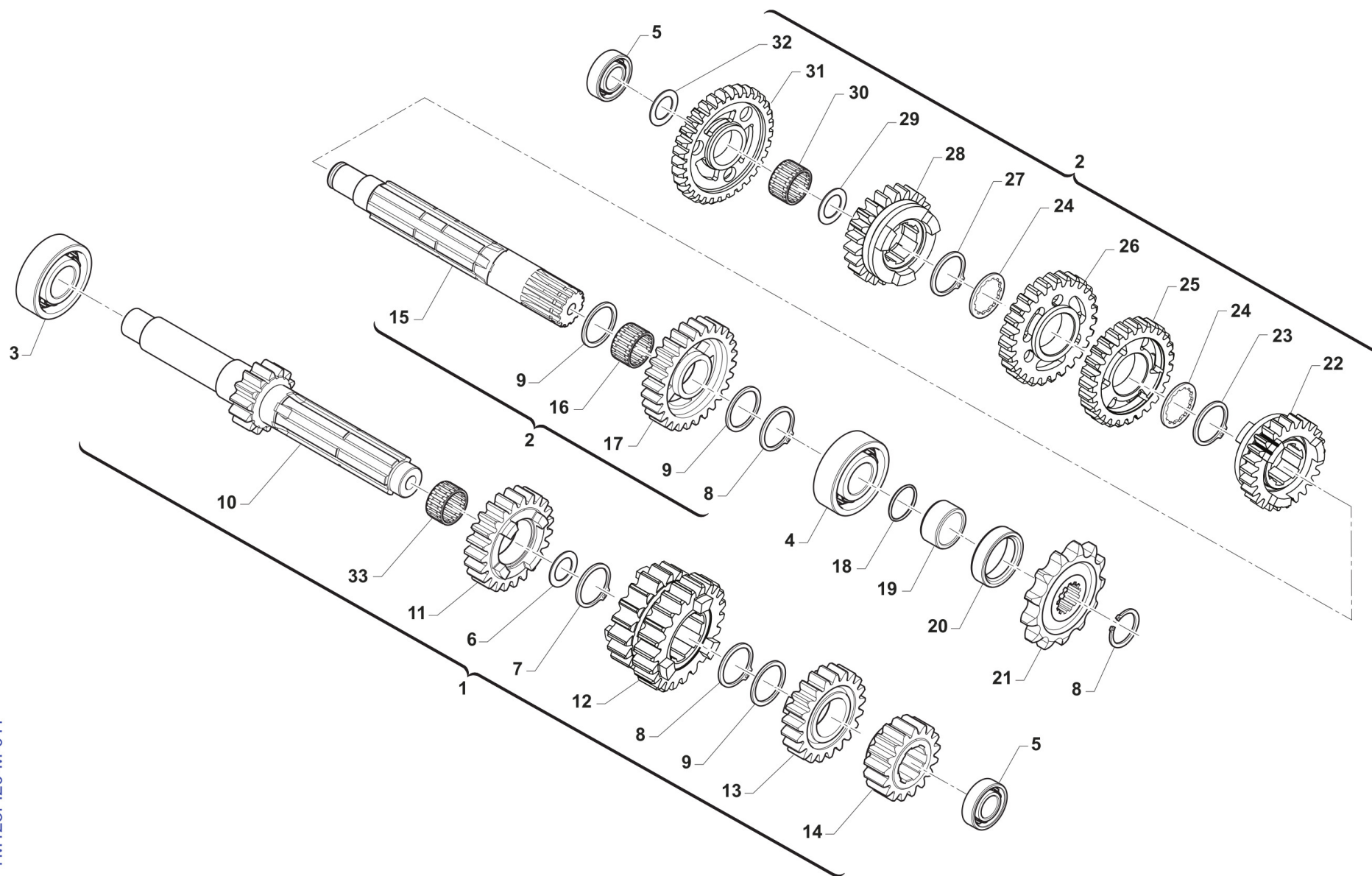

TM125FI20-M-011



2T125MX24-M
MOTORE - ENGINE

CAMBIO MX 6M

10

1	40001	1	ALBERO PRIMARIO CPL 125 MX 6M	PRIMARY SHAFT ASSY 125 MX
2	40002.24	1	ALBERO SECONDARIO CPL 125 MX 6M RINFORZATO	
3	03011	1	CUSCINETTO ALBERO PRIM. 6204 Z C3	BUSH, GEAR MAINSHAFT
4	03010	1	CUSCINETTO 6204 C3 PIG.CATENA	BUSH, COUNTERSHAFT / SPROCKET
5	03080	2	CUSCINETTO 6202 Z C3 (CON RIVETTI) CAMBIO	BUSH, CRAKSHAFT CLUTCH SIDE
6	48041	1	RASAMENTO A/P 27.5X21X1 KZ10B	SPACER, MAINSHAFT 27,5X21X1 KZ
7	49222	1	SEEGER E 21 mm	CIRCLIP D.21 - EXTERNAL
8	49216	3	SEEGER E20 PIGN.-CAMBIO-COPPIA	CIRCLIP D.20 - EXTERNAL
9	48013	3	RASAMENTO A/S 27X20X0,7	SPACER, 27x20x0,7
10	40713	1	ALBERO PRIMARIO Z 14 MX RINF.	MAINSHAFT MX 14T
11	40440	1	INGR. A.P. 5a Z 22 K9B/C 10 CR/E90	GEAR, 5TH (22T) MAINSHAFT
12	40702	1	INGR A.P. 3/4a Z 18/20 CR/E 90	GEAR, 3/4TH(18/20T)MAINSH.MX/E
13	40704	1	INGR A.P. 6a Z 23 CR/90	GEAR, 6TH (23T)MAINSHAFT MX/90
14	40701	1	INGR A.P. 2a Z 16 CR/E 90	GEAR, 2ND (16T) MAINSH.MX/E 90
15	40462.1	1	ALBERO SECONDARIO SCAN. 12 HD	
16	19012	1	GABBIA A RULLI K 20X24X10	BUSH NEEDLE CAGE 20 X 24 X 10
17	40708	1	INGR A.S. 2a Z 29 CR/E 90	GEAR, 2TH (29T) COUNTERSH.CR/E
18	12019	1	O RING PIGNONE CATENA	O-RING, DRIVE GEAR 2075
19	26002.1	1	DISTANZIALE PIGNONE (MOTO)	SPACER, MOTORCYCLE GEAR
20	04003	1	PARAOLIO PIGN.CATENA (26x37x7)	OIL SEAL 26 x 37 x 7
21	40024	1	PIGNONE CAT. Z 11 BR12 M.00/->	SPROCKET 11T, DRIVE M.00/10
21	40025	1	PIGNONE CAT. Z 12 BR12 M.00/->	SPROCKET 12T, DRIVE 125 00/->
21	40026	1	PIGNONE CAT. Z 13 BR12 M.00/->	SPROCKET 13T, DRIVE 125 00/->
22	40712	1	INGR A.S. 6a Z 22 CR/90	GEAR, 6TH(22T)COUNTERSH.MX/E90
23	49217	1	SEEGER E22 ANELLO ALB/S	CIRCLIP D.22 - COUNTERSHAFT
24	48011	2	RASAMENTO DENT.A/S 27X22X0,75	SPACER, 27x22x0,75
25	40710.1	1	INGR A.S. 4a Z 25 HD	
26	40709.1	1	INGR A.S. 3a Z 27 HD	



2T125MX24-M
MOTORE - ENGINE

CAMBIO MX 6M

10

27	49217.1	1	SEEGER RETTIFICATO PER 40510	SEEGER RING FOR CODE 40510
28	40510	1	INGR A.S. 5a Z 24 CR/E 90	GEAR, 5TH (24T) COUNTERSHAFT
29	48012	1	RASAMENTO A/S M/M SPESS.0,5	SPACER, 26x17x0,5
30	19011	1	GABBIA A RULLI K 17X21X10	BUSH CAGE 17 X 21 X 10
31	40470	1	INGRANAGGIO A.S. 1a Z 31 MX	GEAR 1St M X (31T) COUNTERSHAFT
32	48010	1	RASAMENTO ALB/S.28X15X0,5 INGI	SPACER, 28x15x0,5
33	19071	1	GABBIA A 20X24X10 IN DUE META'	NEEDLE CAGE 20X24X10 TWO PIEC.



2T125MX24-M
MOTORE - ENGINE

VITI COPERCHI

11

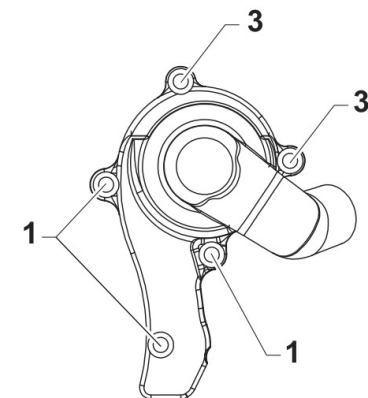
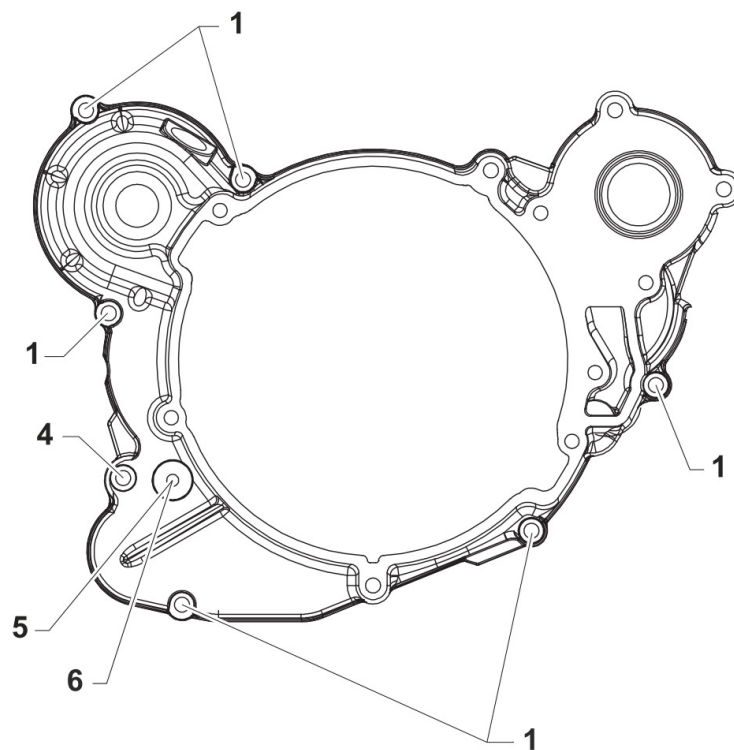
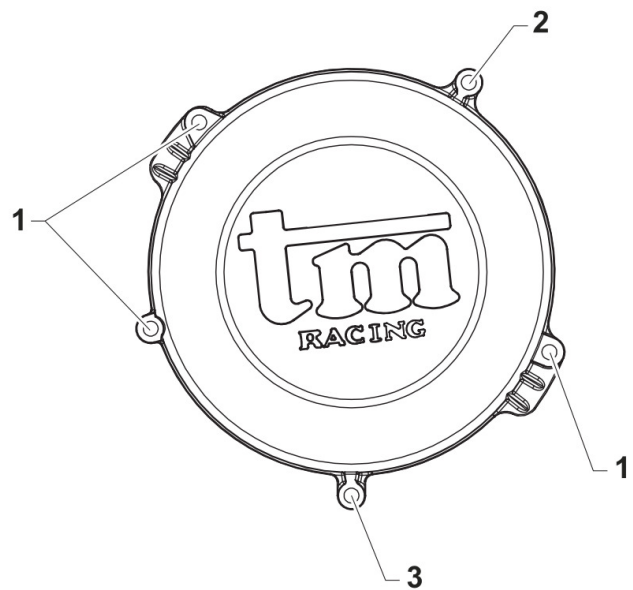

0181



2T125MX24-M
MOTORE - ENGINE

VITI COPERCHI

11

1	49476	12	VITE TCEI 5X20 UNI 5931	BOLT TCEI 5X20
2	49563	1	VITE TCEI 6X85	SCREW TCEI 6X85
3	49595	3	VITE TCEI 5X80 UNI 5931-912 Brun	BOLT TCEI 5X80
4	49477	1	VITE TCEI 5X25 UNI 5931-912	BOLT TCEI 5X25
5	49480	1	VITE TCEI 6X10 UNI 5931	BOLT TCEI 6X10
6	49104	1	RONDELLA 6 x 10 x 1,5 ALLUMINIO	WASHER 6 x 10 x 1.5 ALUMINUM



2T125MX24-M
MOTORE - ENGINE

VITI BASAMENTO

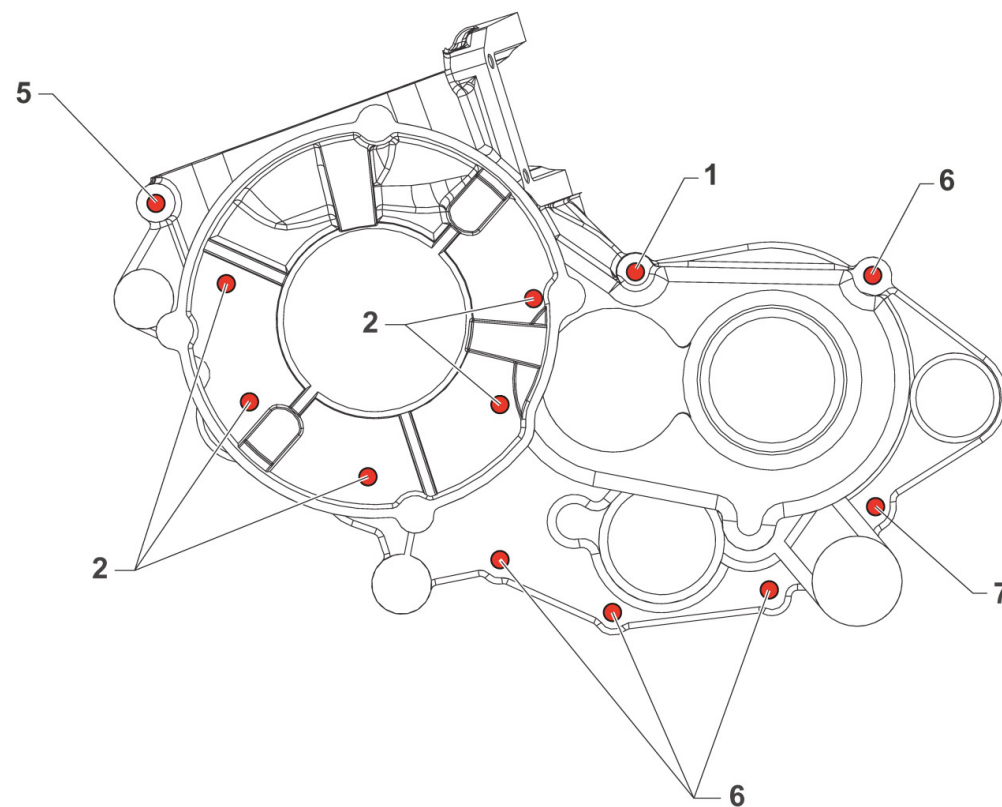
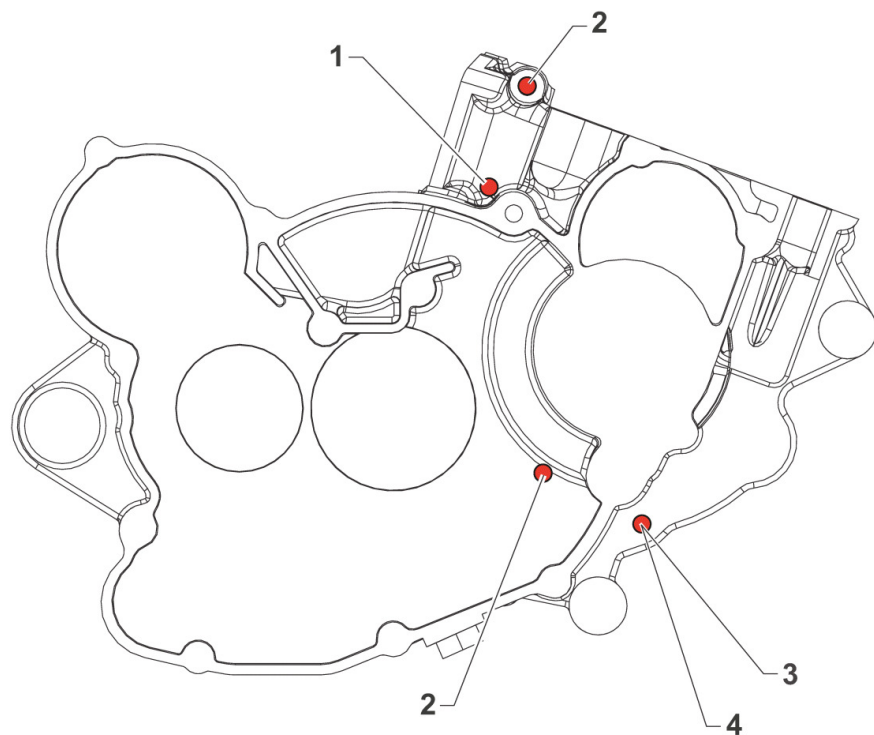



2T125MX24-M
MOTORE - ENGINE

VITI BASAMENTO

12

1	49491	2	VITE TCEI 6X55	BOLT TCEI 6X55
2	49489	7	VITE TCEI 6X45 UNI 5931	BOLT TCEI 6x45
3	49104	1	RONDELLA 6 x 10 x 1,5 ALLUMINIO	WASHER 6 x 10 x 1.5 ALUMINUM
4	49480	1	VITE TCEI 6X10 UNI 5931	BOLT TCEI 6X10
5	49490	1	VITE TCEI 6X50 UNI 5931	BOLT TCEI 6X50
6	49487	4	VITE TCEI 6X35 UNI 5931	BOLT TCEI 6X35
7	49488	1	VITE TCEI 6X40	BOLT TCEI 6x40



2T125MX24-M
MOTORE - ENGINE

-

01129	2T125MX20-M-01	14	1
01130	2T125MX20-M-01	1	1
02024	2T125MX20-M-01	2	1
03010	2T125MX24-M-10	4	1
03011	2T125MX24-M-10	3	1
03012	2T125MX22-M-09	17	1
03014	2T125AA20-M-08	7	1
03025	2T125AA20-M-08	11	1
03029	2T12520-M-03	16	2
03080	2T125MX24-M-10	5	2
03156	2T125MX20-M-01	18	1
04003	2T125MX24-M-10	20	1
04004	2T125MX22-M-09	26	1
04005	2T12522-M-09	3	1
04017	2T125AA20-M-08	13	1
04034.15	2T125MX22-M-05	18	1
04035	2T12520-M-03	15	2
04115	2T125MX20-M-01	15	1
05277	2T125MX22-M-05	9	1
05509	2T125FI20-M-07	33	1
05516	2T125MX22-M-04	5	1
05526	2T125AA20-M-08	2	1
05527	2T125AA20-M-08	6	1
05528	2T125AA20-M-08	16	1
05530	2T125MX20-M-01	9	1
05531	2T125MX20-M-01	9	1
05532	2T125MX20-M-01	9	1
05533	2T125MX20-M-01	9	1

05534	2T125MX20-M-01	9	1
05535	2T125MX20-M-01	9	1
05621	2T125MX22-M-05	19	1
06011	2T125MX20-M-01	7	1
09004.1	2T12520-M-03	3	2
09008	2T12520-M-03	4	1
10022.94	2T12520-M-03	1	1
10022.95	2T12520-M-03	1	1
10022.96	2T12520-M-03	1	1
10022.97	2T12520-M-03	1	1
10022.98	2T12520-M-03	1	1
11069	2T12520-M-03	2	2
12003	2T125MX20-M-01	3	1
12019	2T125MX24-M-10	18	1
12021	2T125MX20-M-01	4	1
12026	2T125MX22-M-05	12	1
12042	2T12522-M-02	10	1
12259	2T125FI20-M-07	30	1
12260	2T12522-M-09	7	1
13009	2T125MX22-M-05	16	1
13081	2T125MX20-M-01	28	1
13086	2T125MX22-M-05	13	1
15230	2T125MX22-M-04	1	1
16006	2T12522-M-09	16	1
16008	2T12522-M-09	5	1
16009	2T125MX22-M-09	6	1
16012	2T125MX22-M-09	13	2
16020	2T125FI20-M-07	2	5

16039	2T12522-M-09	9	1
16066	2T125MX20-M-01	26	1
16252	2T125MX22-M-09	22	1
17015	2T12520-M-03	8	1
18053.2	2T12520-M-03	9	1
18091.4	2T12520-M-03	7	1
18125.2	2T12520-M-03	10	1
18239	2T12520-M-03	6	2
18241	2T12520-M-03	11	1
18242	2T12520-M-03	12	1
19010	2T12522-M-09	13	1
19011	2T125MX24-M-10	30	1
19012	2T125MX24-M-10	16	1
19013	2T125FI20-M-07	21	2
19020	2T125FI20-M-07	6	1
19021	2T125FI20-M-07	5	1
19034	2T12520-M-03	5	1
19041	2T125MX22-M-09	31	1
19052	2T125FI20-M-07	32	1
19060	2T125MX20-M-01	13	1
19061	2T125MX20-M-01	33	1
19071	2T125MX24-M-10	33	1
20061	2T125MX22-M-05	10	1
20074	2T125MX22-M-05	11	1
21005	2T125FI20-M-07	18	6
21009	2T12522-M-02	19	1
21017	2T125MX20-M-01	6	1
22065.15	2T125MX20-M-01	31	1



2T125MX24-M
MOTORE - ENGINE

-

22500	2T12522-M-02	20	1
22502.20	2T12522-M-02	21	1
25000	2T125FI20-M-07	17	1
25099.14	2T125FI20-M-07	13	1
26001	2T125FI20-M-07	7	1
26002.1	2T125MX24-M-10	19	1
26005	2T12522-M-09	4	1
26006	2T125MX22-M-09	7	1
26007	2T125MX22-M-09	23	1
26021	2T125MX22-M-09	15	1
26022	2T125MX22-M-09	9	1
26023	2T125MX22-M-09	32	1
26043	2T125MX22-M-05	4	1
26044	2T125MX22-M-05	5	1
26050	2T125MX22-M-09	3	1
26051	2T125MX22-M-09	5	1
26060	2T125MX22-M-09	10	1
26061	2T125MX22-M-09	11	1
26062	2T125MX22-M-09	12	2
26063.12	2T125MX22-M-09	21	1
26130.12	2T125MX20-M-01	29	1
26130.13	2T125MX20-M-01	29	1
26130.14	2T125MX20-M-01	29	1
26130.15	2T125MX20-M-01	29	1
26130.16	2T125MX20-M-01	29	1
26130.17	2T125MX20-M-01	29	1
26130.18	2T125MX20-M-01	29	1
26130.19	2T125MX20-M-01	29	1

26147	2T125MX20-M-01	30	1
26167	2T125MX20-M-01	34	1
26168	2T125MX20-M-01	24	1
26188	2T12522-M-09	12	1
26212	2T125FI20-M-07	25	2
26254	2T12522-M-09	17	1
26258	2T125MX20-M-01	16	1
28009	2T125AA20-M-08	15	1
28051	2T12522-M-09	14	1
28059	2T125MX20-M-01	32	1
28062	2T125AA20-M-08	9	1
28100	2T125MX22-M-09	4	1
28108	2T125MX20-M-01	21	1
28109	2T12522-M-02	9	1
28263	2T125MX20-M-01	23	1
28266.0	2T12522-M-02	5	1
28266.1	2T12522-M-02	5	1
30174	2T125AA20-M-08	3	1
30176.15	2T125MX22-M-05	8	1
30187	2T125AA20-M-08	1	1
30194.20	2T125AA20-M-08	17	1
30205	2T125FI20-M-07	29	1
30206	2T125FI20-M-07	34	1
30211	2T125MX22-M-04	6	1
30217	2T125MX20-M-01	11	1
30291	2T12522-M-02	1	1
30392	2T12522-M-02	2	1
33004	2T125MX22-M-09	20	1

33016	2T125MX22-M-09	30	1
33255	2T125MX22-M-09	29	1
33256	2T125MX22-M-09	18	1
35012	2T125FI20-M-07	10	8
35015	2T125FI20-M-07	4	1
35019	2T125FI20-M-07	9	7
35025	2T125FI20-M-07	8	1
35026	2T125FI20-M-07	16	1
35043	2T125FI20-M-07	22	1
35125	2T125FI20-M-07	31	1
35264	2T125FI20-M-07	28	1
40001	2T125MX24-M-10	1	1
40002.24	2T125MX24-M-10	2	1
40022	2T125FI20-M-07	27	1
40024	2T125MX24-M-10	21	1
40025	2T125MX24-M-10	21	1
40026	2T125MX24-M-10	21	1
40029	2T125FI20-M-07	26	1
40071	2T125AA20-M-08	10	1
40303	2T12520-M-03	14	1
40310	2T125MX22-M-09	14	1
40350	2T12522-M-09	15	1
40351	2T12522-M-09	20	1
40402	2T125FI20-M-07	19	1
40409	2T125FI20-M-07	20	1
40440	2T125MX24-M-10	11	1
40462.1	2T125MX24-M-10	15	1
40470	2T125MX24-M-10	31	1



2T125MX24-M
MOTORE - ENGINE

-

40510	2T125MX24-M-10	28	1
40701	2T125MX24-M-10	14	1
40702	2T125MX24-M-10	12	1
40704	2T125MX24-M-10	13	1
40708	2T125MX24-M-10	17	1
40709.1	2T125MX24-M-10	26	1
40710.1	2T125MX24-M-10	25	1
40712	2T125MX24-M-10	22	1
40713	2T125MX24-M-10	10	1
43038	2T12522-M-09	1	1
43039.01	2T12522-M-09	8	1
43048	2T125MX22-M-09	27	1
43250.03	2T12522-M-09	10	1
48002	2T125FI20-M-07	14	1
48003	2T125FI20-M-07	23	1
48004	2T12522-M-09	19	2
48010	2T125MX24-M-10	32	1
48011	2T125MX24-M-10	24	2
48012	2T125MX24-M-10	29	1
48013	2T125MX24-M-10	9	3
48041	2T125MX24-M-10	6	1
490021	2T12522-M-02	17	5
49009	2T125MX22-M-05	20	1
49010	2T12520-M-03	17	1
49020	2T125MX22-M-05	2	2
49027	2T125MX22-M-05	3	2
49052	2T125FI20-M-07	11	1
49056	2T125MX22-M-04	4	1

49057	2T125FI20-M-07	1	5
49094	2T12520-M-03	13	1
49103	2T125AA20-M-08	4	1
	2T125MX22-M-05	6	1
49104	2T125FI20-M-12	6	1
	2T125FI20-M-13	3	1
49124	2T12522-M-02	12	1
49127	2T125FI20-M-07	12	1
49211	2T125FI20-M-07	3	1
49212	2T125MX22-M-09	28	1
49214	2T12522-M-09	18	1
49215	2T125AA20-M-08	12	1
49216	2T125MX24-M-10	8	3
49217	2T125MX24-M-10	23	1
49217.1	2T125MX24-M-10	27	1
49220	2T125MX20-M-01	19	1
49222	2T125MX24-M-10	7	1
49300	2T125AA20-M-08	5	1
49301	2T125MX22-M-05	7	1
49355	2T125MX20-M-01	27	3
49358	2T125MX20-M-01	5	6
49368	2T12522-M-09	2	1
49399	2T125MX20-M-01	10	1
49405	2T125MX22-M-09	8	2
49406	2T12522-M-09	6	1
49440	2T125MX22-M-09	33	2
49472	2T12522-M-02	3	1
49476	2T125FI20-M-12	1	12

49477	2T125FI20-M-12	4	1
	2T125MX22-M-04	7	4
49478	2T12522-M-02	18	4
49480	2T125FI20-M-12	5	1
	2T125FI20-M-13	4	1
49483	2T125MX22-M-09	16	2
49484	2T125MX22-M-04	3	2
	2T125MX22-M-05	14	2
	2T125MX22-M-05	15	2
49485	2T125MX22-M-09	25	1
49486	2T125FI20-M-07	24	2
49487	2T125FI20-M-13	6	4
49488	2T125FI20-M-13	7	1
49489	2T125FI20-M-13	2	7
49490	2T125FI20-M-13	5	1
49491	2T125FI20-M-13	1	2
49563	2T125FI20-M-12	2	1
49595	2T125FI20-M-12	3	3
49603	2T125MX22-M-04	2	2
	2T125MX22-M-09	2	1
49630	2T125MX20-M-01	20	1
49632	2T12522-M-02	6	2
49638	2T125MX22-M-09	1	1
49640	2T125MX20-M-01	8	4
	2T125MX22-M-05	1	4
49676	2T125MX20-M-01	35	1
49689	2T125AA20-M-08	14	1
49727	2T125FI20-M-07	15	6



2T125MX24-M
MOTORE - ENGINE

-

49757	2T125MX20-M-01	17	1
49874	2T125MX20-M-01	22	1
49881	2T12522-M-02	13	1
49929	2T12522-M-02	7	1
49973	2T12522-M-02	15	4
50030	2T12520-M-03	14	1
50124	2T125FI20-M-07	13	1
51054	2T125MX22-M-05	17	2
72251	2T12522-M-02	8	2
F12301	2T12522-M-02	11	2
F12308	2T125MX20-M-01	12	1
F16416	2T12522-M-09	21	1
F19536	2T125MX20-M-01	25	1
F33314	2T125MX22-M-09	19	2
F48354	2T12522-M-09	22	1