



USES AND
RACOMMENDS



www.tmracing.it

TM Racing SpA - Via Fano, 6
61122 Pesaro - ITALY
Phone: +39 0721 25113

2T144EN24-M

**MOTORE
ENGINE**

12/12/2023



INFORMAZIONI GENERALI

Il presente catalogo serve per richiedere con esattezza le parti di ricambio.

Nelle ordinazioni indicare:

1) Il numero di matricola del Telaio che è stampigliato sul lato destro del canotto di sterzo. Nei modelli EN, SMR, SMR il numero di matricola è riportato anche su una targhetta posta sul lato sinistro (Vedi foto).

2) il numero di serie del Motore. E' posto sulla sinistra del motore tra la leva cambio e i coperchio accensione (Vedi foto).

3) Il codice dei particolari seguito dalla descrizione.

4) Il colore per i pezzi verniciati o comunque colorati.

Le indicazioni destra e sinistra si riferiscono ai lati del veicolo rispetto al senso di marcia.

Foto e disegni sono solo a scopo informativo e potrebbero non corrispondere esattamente alle caratteristiche dei prodotti.

GENERAL INFORMATION

The present spare parts catalogue enables one to order exactly the right spare part.

When ordering specify:

1) The frame serial number. It is embossed on the right side of the steering metal tube. In the EN, SMR and SMR models, the serial number is also stated on a plate positioned on the left hand side (See photo).

2) The engine serial numer. It is located on the left side of the engine between the gear lever and the ignition cover (See photo).

3) The part's code number followed but its description.

4) Indicate colour for painted or colored parts.

References to right and left apply to the vehicle in terms of its direction of movement.

Photos and drawings are for informational purposes only and may not exactly match the characteristics of the products.

NOTE – LEGENDA

MY

NOVITA' INTRODOTTA DIFFERENTE O NON PRESENTE NEL MODELLO DELL'ANNO PRECEDENTE

PART DIFFERENT OR NOT PRESENT IN THE REVIOUS YEAR MODEL

5M

MOTORE CON CAMBIO A 5 MARCE
ENGINE WITH 5 GEARS SPEED

6M

MOTORE CON CAMBIO A 6 MARCE
ENGINE WITH 6 GEARS SPEED

KS

MOTORE CON SOLO KICK STARTER
ENGINE WITH KICK STARTER ONLY

ES

MOTORE CON AVVIAMENTO ELETTRICO
ENGINE WITH ELECTRIC STARTER

X

RICAMBIO NON DISPONIBILE ALLA VENDITA
PART CAN NOT BE SOLD SEPARATELY



Le illustrazioni riportate in questo manuale sono fornite solo come riferimento e possono variare dal prodotto effettivo,

Dati indicativi soggetti a modifiche senza impegno di preavviso.

The illustrations in this manual are for reference only and may vary from the actual product.

All data are subject to modification without prior notice.



2T144EN24-M
MOTORE - ENGINE

CILINDRO - CYLINDER.....	4
MOTORINO VALVOLA - ELECTRIC VALVE SYSTEM.....	7
ALBERO MOTORE - PISTONE - CRANKSHAFT - PISTON.....	9
ACCENSIONE - IGNITION.....	11
BASAMENTO - CRANKCASE.....	13
FORCHETTE CAMBIO - GEAR FORKS.....	15
FRIZIONE - CLUTCH.....	18
COPERCHI FRIZIONE E CENTRIFUGA.....	21
CAMBIO ENDURO - GEARBOX EN.....	23
VITI COPERCHI.....	26
VITI BASAMENTO.....	28
-	30



2T144EN24-M
MOTORE - ENGINE

CILINDRO
CYLINDER

1

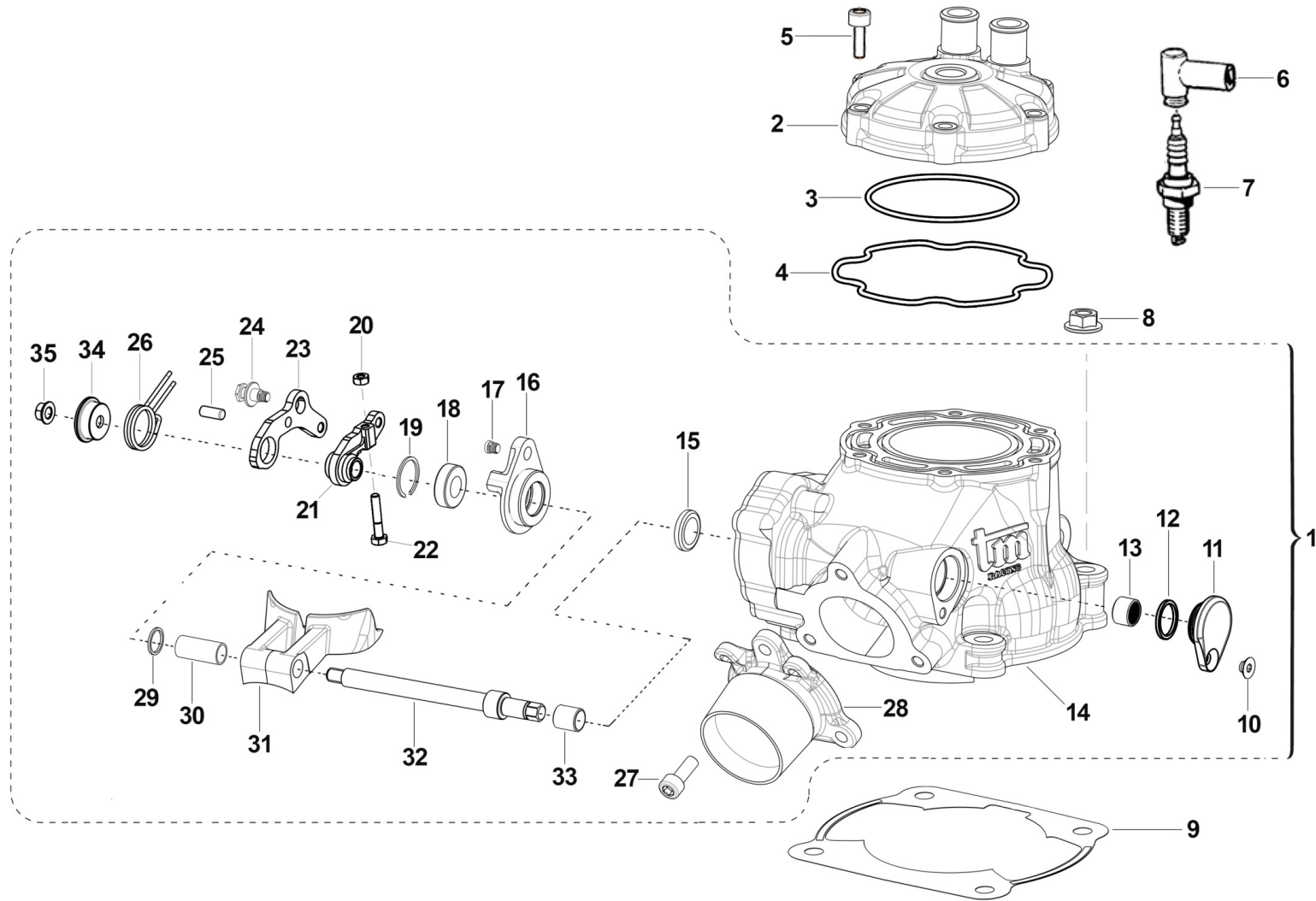



2T144EN24-M
MOTORE - ENGINE

CILINDRO
CYLINDER

1	01134	1	MY20	CILINDRO 144 2T MX/EN MY2020 CPL (CARB)	CYLINDER 144 2S EN/MX MY20 ASSY
2	02025	1		TESTA 144 CR/E EV M. 2013	HEAD 144cc MX/END M.13->
3	12003	1		O RING TESTA 125 90/06KVK8-910 NBR	O-RING, HEAD 125 90/06 KV8910
4	12021	1		O RING PREFORMATO CIL.125/12->	O-RING, HEAD 125EV M. 2012
5	49358	6		VITE TE F/R 6X30 Ch.8	BOLT 6X30 T.8
6	21017	1		PIPETTA CANDELA NGK LB05EMH	CAP, NGK SPARK PLUG LB05EMH
7	06011	1		CANDELA NGK BR9EG	SPARK PLUG, NGK BR9EG
8	49640	4		DADO M 8 FLANGIATO CHIAVE 12	NUT 8mm, FLANGE
9	05530	1		GUARN. B/CIL 125 M.2012 0,10	GASKET, CYL 125EV M.12/-> 0,10
9	05531	1		GUARN. B/CIL 125 M.2012 0,15	GASKET, CYL 125EV M.12/-> 0,15
9	05532	1		GUARN. B/CIL 125 M.2012 0,20	GASKET, CYL 125EV M.12/-> 0,20
9	05533	1		GUARN. B/CIL 125 M.2012 0,30	GASKET, CYL 125EV M.12/-> 0,30
9	05534	1		GUARN. B/CIL 125 M.2012 0,40	GASKET, CYL 125EV M.12/-> 0,40
9	05535	1		GUARN. B/CIL 125 M.2012 0,50	GASKET, CYL 125EV M.12/-> 0,50
10	49399	1		VITE TSEI 5X12	BOLT TSEI 5x12
11	30217	1		TAPPO SX ALB.COM.VALV.PAL.125	SIDE COVER
12	F12308	1		O RING 17,5 - 1,5	O-RING 17,5 - 1,5
13	19060	1		ASTUCCIO A RULLI HK 1212	NEEDLE CAGE HK 1212
14	01133	1	MY20	CILINDRO 144 2T MX/EN MY2020 NUDO (CARB)	CYLINDER 144 2S MY20
15	04115	1		PARAOLIO G 12X18X3	OIL SEAL 12x18x3
16	26258	1	MY20	FLANGIA PORTACUSC. ALB.VALV.250/300 Fi 125/144 MY 20/24	FLANGE, BEARING HOLDER
17	49757	1		VITE TBCE 5 X 12	BOLT TBCE 5X12
18	03156	1		CUSCINETTO V.SC.C.12 698LLU/5K	BUSH, EXHAUST VALVE 698LLU
19	49220	1		SEEGER INT.19	SEEGER I 19
20	49630	1	MY20	DADO M 4 (BASSO)	NUT 4mm, LOW
21	28108	1	MY20	LEVA INTERNA COMANDO VALVOLE EES-2 125/144 2020	LEVER, INTERNAL, VALVE
22	49874	1	MY20	VITE TE 4X16	BOLT TE 4X16
23	28263	1	MY20	LEVA ESTERNA COMANDO VALVOLE EES-2	LEVER, EXTERNAL, VALVE



2T144EN24-M
MOTORE - ENGINE

CILINDRO
CYLINDER

24	26168	1	MY20	PERNO MOLLA EES-2 16066	PIN, SPRING
25	F19536	1	MY20	RULLO D. 5 X 12 M6 DIN 6325	PIN 5X12
26	16066	1	MY20	MOLLA EES-2	SPRING EES-2
27	49355	3		VITE TE F/R 6X16 Ch.8	BOLT 6X16 T.8
28	13081	1		COLLETTORE SCA. 125 12/-> 3F	MANIFOLD EXHAUST 125cc 12->
29	26130.12	1		SPESS. REG. CIL.125 2012 1.2	SPACER CYL. 125 ->12 1.2
29	26130.13	1		SPESS. REG. CIL.125 2012 1.3	SPACER CYL. 125 ->12 1.3
29	26130.14	1		SPESS. REG. CIL.125 2012 1.4	SPACER CYL. 125 ->12 1.4
29	26130.15	1		SPESS. REG. CIL.125 2012 1.5	SPACER CYL. 125 ->12 1.5
29	26130.16	1		SPESS. REG. CIL.125 2012 1.6	SPACER CYL. 125 ->12 1.6
29	26130.17	1		SPESS. REG. CIL.125 2012 1.7	SPACER CYL. 125 ->12 1.7
29	26130.18	1		SPESS. REG. CIL.125 2012 1.8	SPACER CYL. 125 ->12 1.8
29	26130.19	1		SPESS. REG. CIL.125 2012 1.9	SPACER CYL. 125 ->12 1.9
30	26147	1	MY20	BOCCOLA DIST. CIL. 250/300 2015 + 125 2020	BUSH
31	22147	1		VALVOLE SCARICO 144 EV M2013	POWER VALVE 144cc MY13
32	28059	1		ALBERO COMANDO PALETTE 125	SHAFT, BOOSTER 125
33	19061	1		BOCCOLA IR 8X12X12.5	BUSH, IR 1X12X12,5
34	26167	1	MY20	PIATTELLO GUIDA MOLLA EES-2 16066	COLLAR, SPRING
35	49676	1	MY20	DADO M 6X1 FLANG. AUTOBL.ACC.	NUT, FLANGED M6 X 1 S.B.



2T144EN24-M
MOTORE - ENGINE

MOTORINO VALVOLA
ELECTRIC VALVE SYSTEM

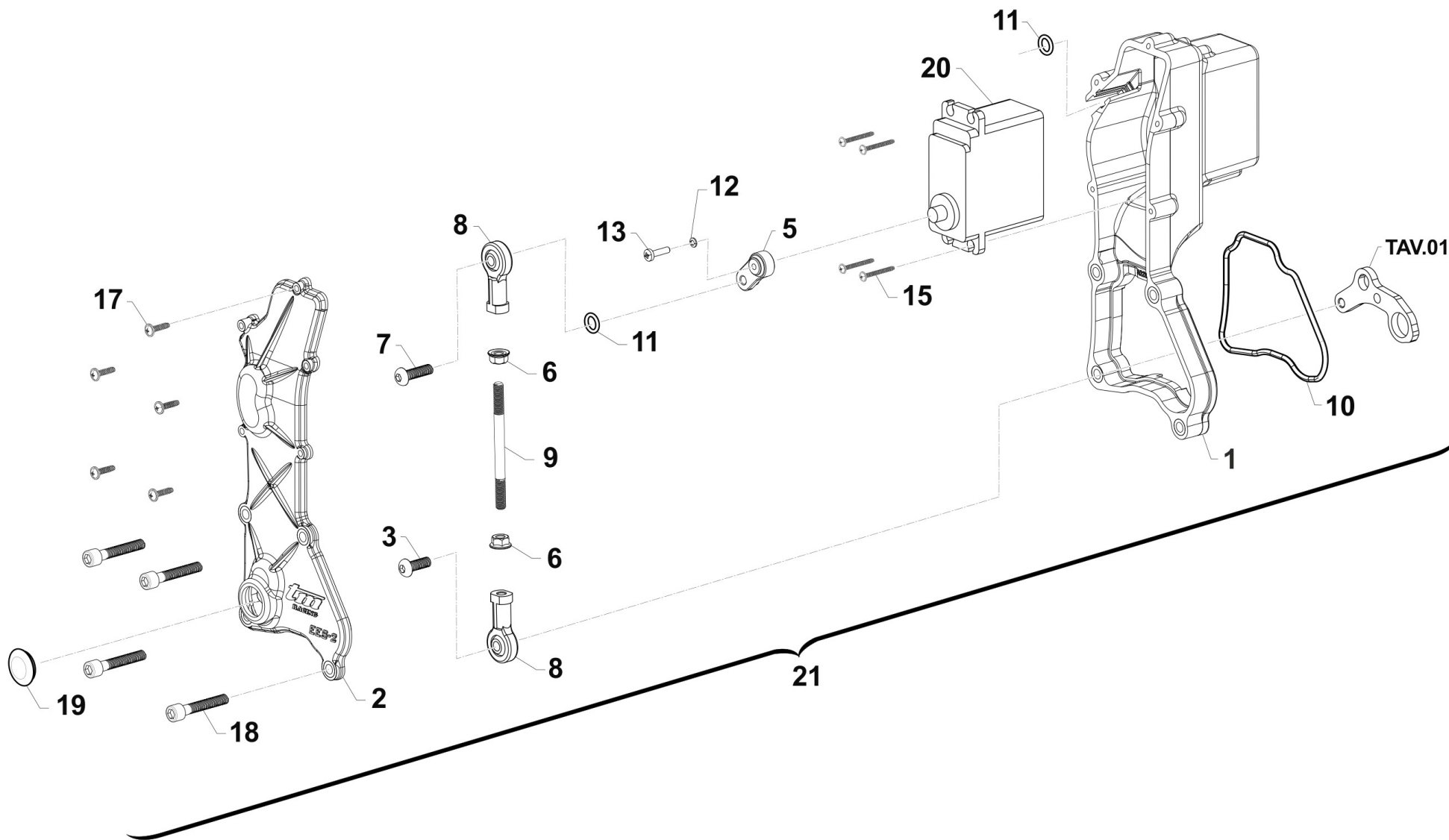

TM 0709



2T144EN24-M
MOTORE - ENGINE

MOTORINO VALVOLA
ELECTRIC VALVE SYSTEM

2

1	30291	1	CARTER EES-2 125/144 2T FI	CASE, PLASTIC, ENGINE VALVE
2	30392	1	COPERCHIO CARTER EES-2 125/144 2T FI	
3	49472	1	VITE TCEI 5X12 UNI 5931-912 Brun	BOLT TCEI 5X12
5	28266.0	1	LEVA SERVOMOTORE EES-2 DENTATURA 0	LEVER
5	28266.1	1	LEVA SERVOMOTORE EES-2 DENTATURA 1	LEVER
6	49632	2	DADO M 5 x 0,8 ZB	NUT 5mm
7	49929	1	VITE 10.9 TBCEI 5 x 18 UNI 7380	BOLT
8	72251	2	SNODO MECCANISCO VALVOLA EES-2 125/250/300	JOINT EXHAUST VALVE EES-2 250/300
9	28109	1	ASTINA COLLEGAMENTO UNIBALL EES-2 125/144 2020	ROD, UNIBALL 125/144 MY20
10	12042	1	O RING COP. VALVOLA EES-2	O-RING
11	F12301	2	O RING 106 4T PIOGGIA CAMBIO	O-RING, 106 GEAR F.S.
12	49124	1	RONDELLA SCHNORR ZIG. 2.5	
13	49881	1	VITE T.C. 2,5X12	
15	49973	4	VITE STS-Plus KN6031 2.2X20 PLASTICA	BOLT
17	490021	5	VITE TCBL 3.0X 16 FL. X PLAST.	
18	49478	4	VITE TCEI 5X30 UNI 5931	BOLT TCEI 5X30
19	21009	1	TAPPO GOMMA COPERCHIO VALV.SC.	RUBBER, COVER
20	22500	1	SERVOMOTORE VALV.SCARICO HITEC	EL. ENGINE EXHAUST VALVE HITEC
21	22502.20	1	SERVOMOTORE V/SC. CPL 125/144 MY20	EL. ENGINE EXHAUST, 125/144 MY20 ASSY

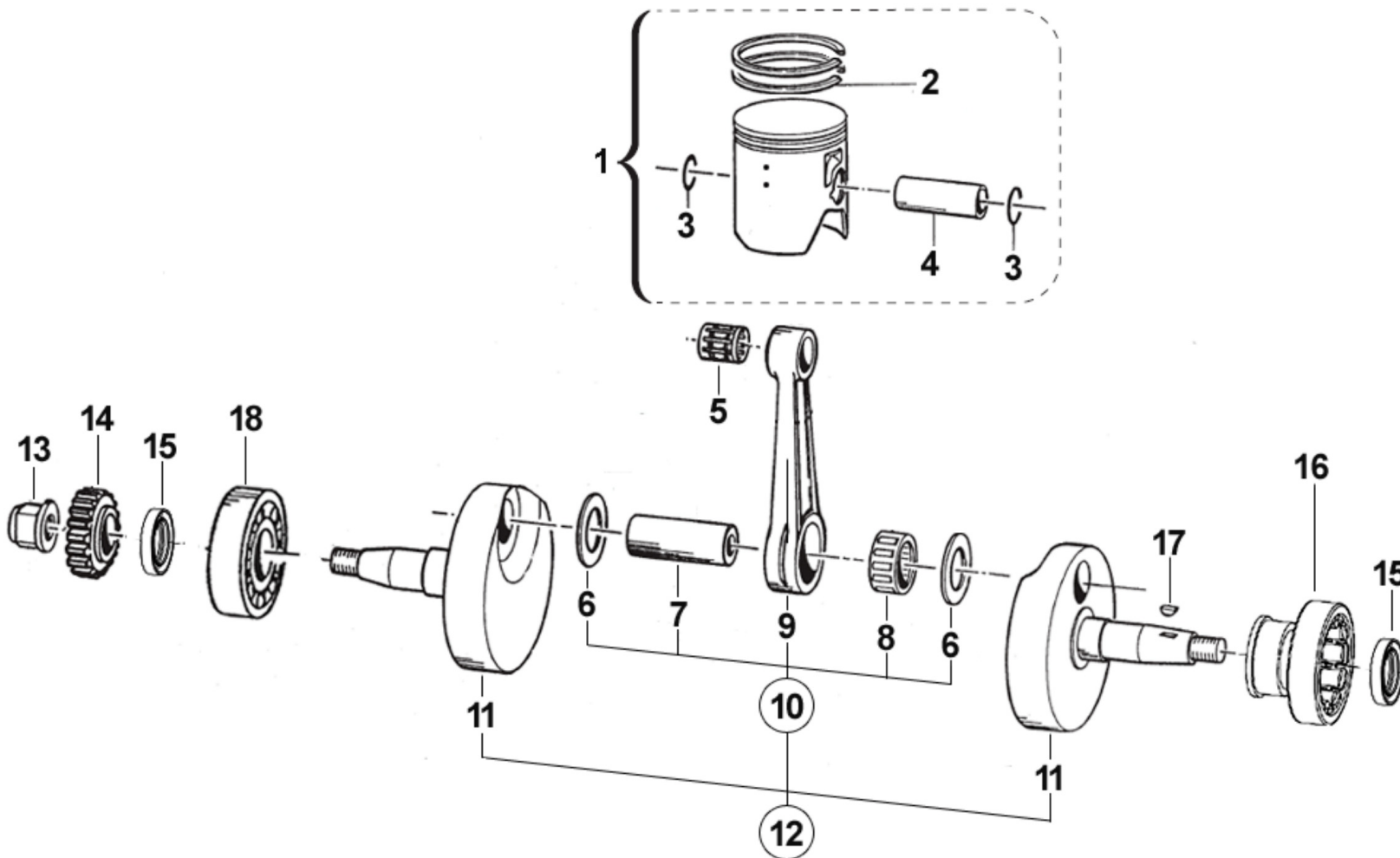

TM14419-003



2T144EN24-M
MOTORE - ENGINE

ALBERO MOTORE - PISTONE
CRANKSHAFT - PISTON

3

1	10023.94	1	PISTONE 55,94 2F 144cc CPL	PISTON 55,94 2R 144cc ASSY
1	10023.95	1	PISTONE 55,95 2F 144cc CPL	PISTON 55,95 2R144cc ASSY
2	11065	2	SEGMENTO 56 X 1 144cc	RING 56X1 144cc
3	09004.1	2	ANELLINO SPINOTTO 15 x 1 PIST.125/144	CLIP, PISTON PIN 125 / 144
4	09008	1	SPINOTTO PISTONE 125 15X41F10	PIN, PISTON 125, 15x41 F10
5	19034	1	GABBIA SPINOTTO 15X19X17,3	TOP END B. 15X19X17,3
6	18248	2	RONDELLA ARGENTATA D.24	WASHER, SILVER ID.24
7	18079	1	ASSE ACCOPP.D.24 mm f.8 c/tapp	CRANKPIN 24 X 50,4 125/144
8	17074	1	GABBIA ARGENTATA D.24X31X16 P.	SILVER CAGE 24x31x16
9	18144	1	BIELLA FORGIATA NUDA 144 cc	CONNECTING ROD 144cc
10	18145	1	BIELLA 144cc CPL	CONROD KIT, 144cc ASSY
11	18177.13	1	COPPIA SEMIALBERI 144 EV 2013	CRANKSHAFT SIDES 144 EV13
12	18178.13	1	ALBERO MOTORE 144 EV 2013 CPL	CRANKSHAFT 144 ASSY EV M13->
13	49094	1	DADO TRASMISS.125 06 M 14 X 1.25	NUT,CLUTCH CENT.14X1.25 125 06
14	40303	1	PIGNONE COPPIA PRIMARIA Z19 CR	PRIMARY DRIVE GEAR 19T MX
14	50030	1	ESTRATTORE PIGNONE COPPIA	PRIMARY GEAR PULLEY
15	04035	2	PARAOLIO 20x30x7 PTFE	OIL SEAL 20 x 30 x 7 PTFE
16	03026	1	CUSCINETTO ALBERO MOTORE NJ206	BUSH, NJ206 CRANKSHAFT
17	49010	1	CHIAVETTA VOLANO 13x5x3	WOODRUFF KEY
18	03255	1	CUSCINETTO ALB.MOTORE 125 M.13	BUSH, CRANKSHAFT 125 M.13

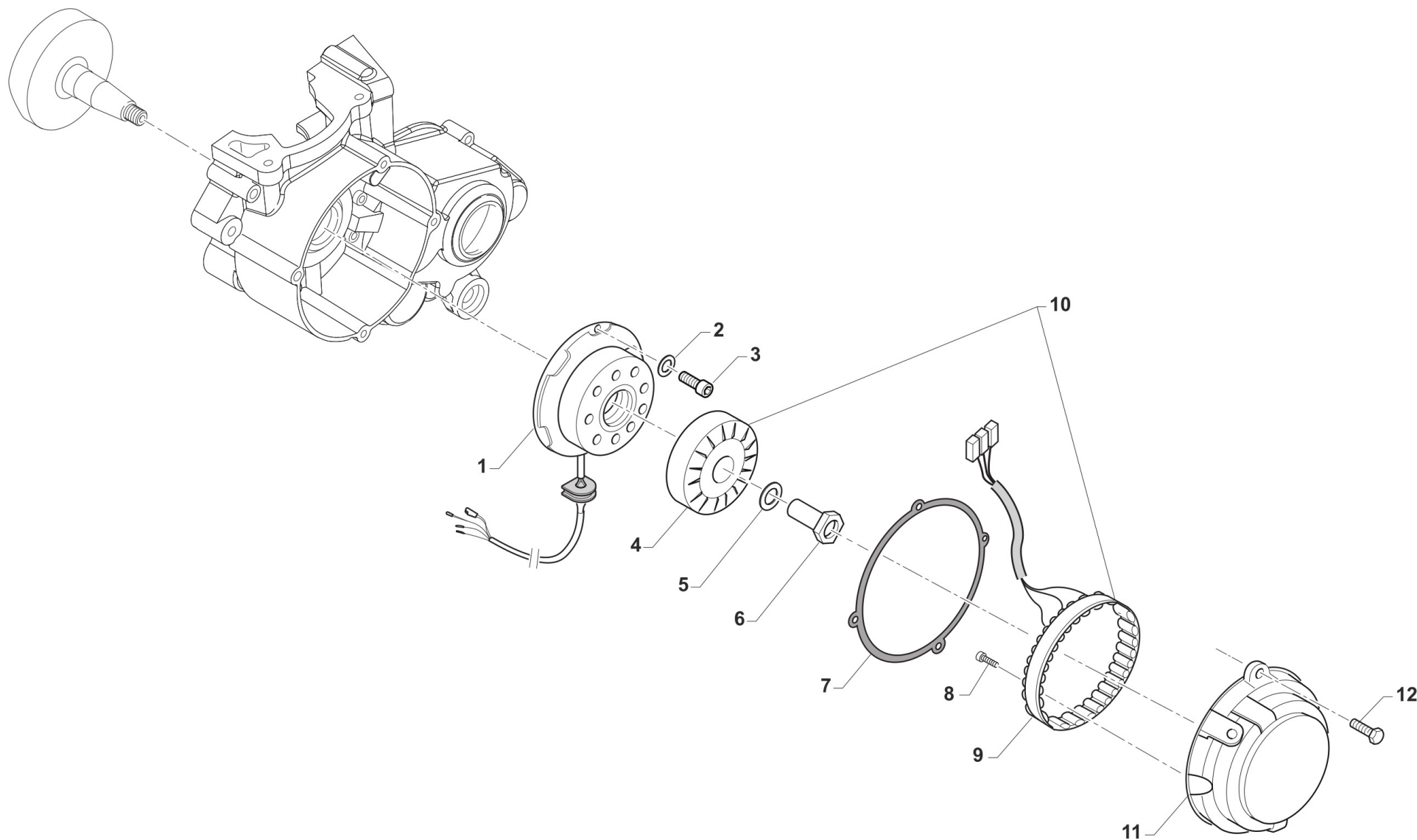



2T144EN24-M
MOTORE - ENGINE

ACCENSIONE
IGNITION

1	15230	1	GENERATORE KOK END 11 MX/E 12	GENERATOR KOK END 11 MX/E 12->
1	50051	1	ESTRATTORE ACCEN.KOK.2T 27X1 S	FLYWHEEL PULLER KOKUSAN 2S
2	49603	2	RONDELLA M 6,4 X 12 X 1,6	WASHER 6x12
3	49484	2	VITE TCEI 6X20	BOLT TCEI 6X20
4	15103	1	ROTORE INTERNO DUCATI	ROTOR, DUCATI ALTERNATOR
5	49618	1	RONDELLA ACCIAIO 18 ALTER.250	STEEL WASHER 18
6	49061	1	DADO X ALTERN.125/250 KOKUSAN	NUT, A.C. GENERATOR KOKUSAN
7	05516	1	GUARN. COP.ACC. 80/125 KOKUSAN	GASKET, KOK.IGNIT.COV. 80/125
8	49470	2	VITE TCEI 4X12	BOLT TCEI 4X12
9	15102	1	STATORE ALTERNATORE DUCATI	STATOR, DUCATI ALTERNATOR
10	15100	1	ALTERNATORE X LUCI ENDURO D.	A.C. GENERATOR DUCATI
11	30210	1	COP. ACCEN. END 80/125 95/07 K	COVER, INGNI.END 125/144 95/->
12	49477	4	VITE TCEI 5X25 UNI 5931-912	BOLT TCEI 5X25

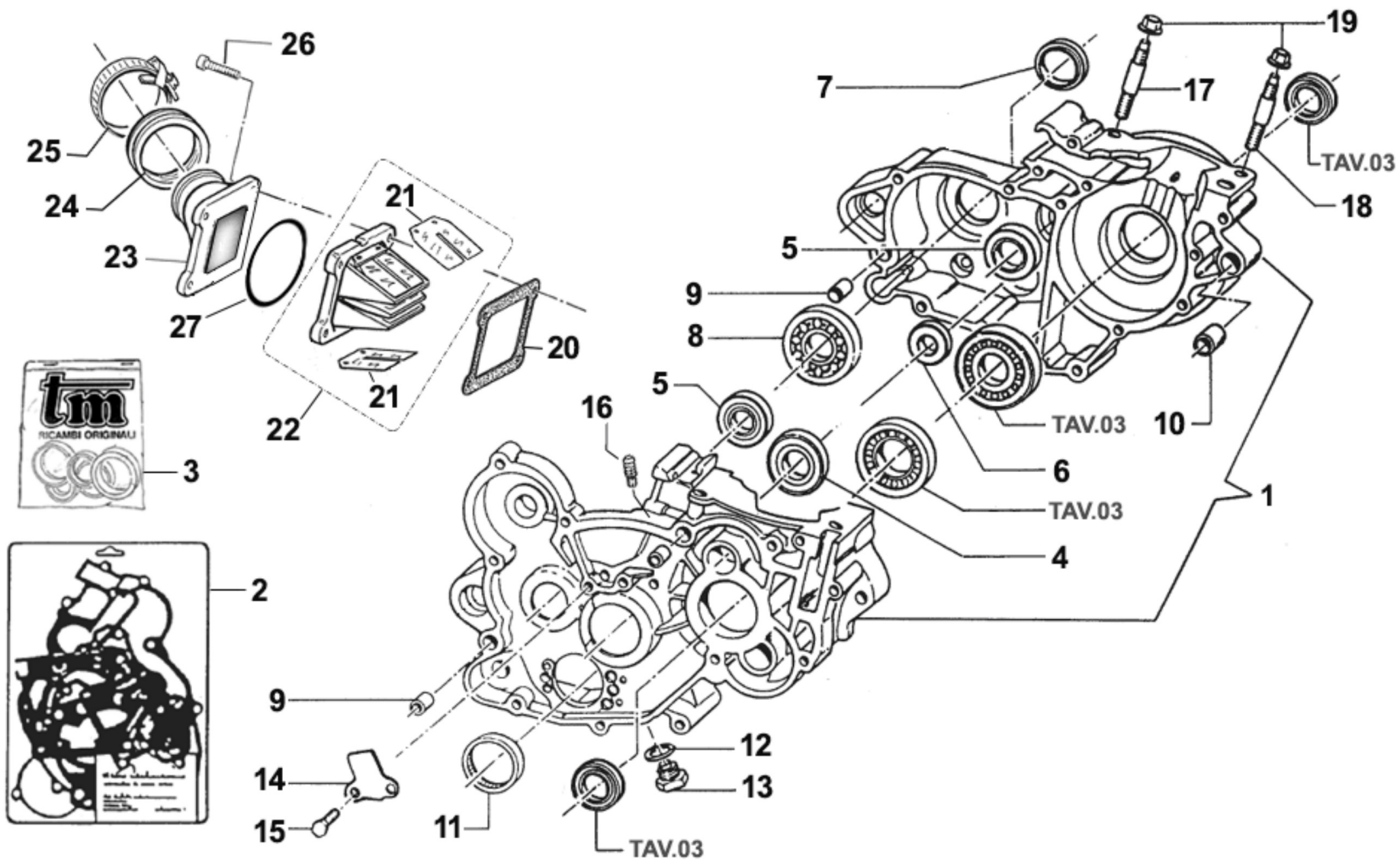



2T144EN24-M
MOTORE - ENGINE

BASAMENTO
CRANKCASE

1	30177.19	1	BASAMENTO MOTORE 144 EV MY 2019	CRANKCASE 144 MY19
2	05621	1	KIT GUARN. + OR 125 2012 V.EL	GASKETS + OR 125cc M.12->
3	04034.15	1	KIT PARAOLI 125 EV M.2015	OIL SEALS 125cc EV M.15->
4	03011	1	CUSCINETTO ALBERO PRIM. 6204 Z C3	BUSH, GEAR MAINSHAFT
5	03009	2	CUSCINETTO 6202 Z C3 RIVETT.	BUSH, 6202 Z C3
6	03012	1	CUSCINETTO DESMODROMICO 6001 2RS	BUSH, 6001 2RS GEAR DRUM
7	04003	1	PARAOLIO PIGN.CATENA (26x37x7)	OIL SEAL 26 x 37 x 7
8	03010	1	CUSCINETTO 6204 C3 PIG.CATENA	BUSH, COUNTERSHAFT / SPROCKET
9	26044	3	GRANO CENTRAGGIO MOTOR.10X13,6	GRUB SCREW 10X13,6
10	26043	1	GRANO CARTER ANT. 14 X 14	GRUB SCREW 14X14
11	19041	1	ASTUCCIO A RULLI DHK 35/12	BUSH NEEDLE CAGE DHK 35/12
12	49103	1	RONDELLA 14X20X1,5 ALLUMINIO	WASHER, 14 X 20 X 1.5 ALUMINUM
13	49301	1	TAPPO OLIO C/CALAM. 2T	OIL PLUG WITH MAGNET
14	26023	1	PIASTRINO CONVOGLIATORE OLIO	PLATE, OIL
15	49440	2	VITE TE 6X14	BOLT TE 6X14
16	49009	1	RACCORDO SFIATO OLIO MX/E F.4	JOINT, OIL BREATHER
17	49161	2	PRIGIONIERO 8 X 64,3 TESTA POST. 144CC M08	STUD
18	49059	2	PRIGIONIERO M8X54.5 CIL144 ANT	
19	49640	4	DADO M 8 FLANGIATO CHIAVE 12	NUT 8mm, FLANGE
20	05277	1	GUARN. PACCO LAMELLE VFORCE 3	GASKET, REED BLOCK VFORCE 3
21	20074	1	LAMELLE V-FORCE3 125/144 07/->	REEDS, V-FORCE3 125/144 07/->
22	20061	1	PACCO LAM 125/144 VF3 M. 08/->	REEDS BOX VF3 125/144 M. 08/->
23	13086	1	COLLETTORE AI ASP. 125cc 2013	ALL. INTAKE MANIFOLD 125 cc M.13->
24	13009	1	MANICOTTO COLLETTORE ASP.97/14	MANIFOLD RUBBER,INTAKE M.97/14
25	51054	2	FASCETTA SM9 D.52	CLAMP SM9 D.52mm
26	49484	4	VITE TCEI 6X20	BOLT TCEI 6X20
27	12026	1	O RING CONVOGLIATORE 125 13086	O-RING INLET MANIFOLD 125 13086

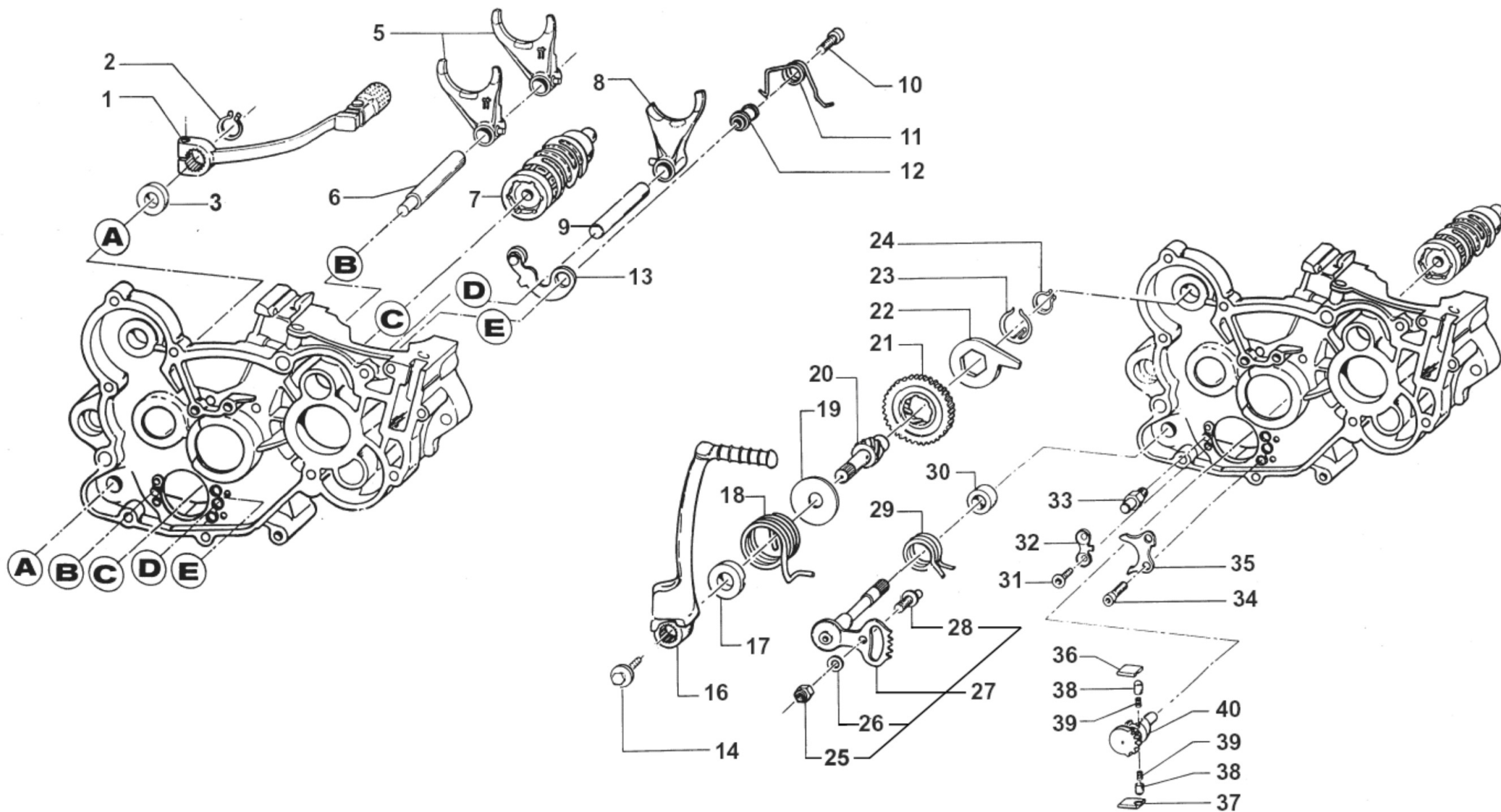



2T144EN24-M
MOTORE - ENGINE

FORCHETTE CAMBIO
GEAR FORKS

1	43049	1	LEVA CAMBIO 2T (485) MY19->	GEAR LEVER 250 / 300 T.STR. EL.ST. M.19->
2	49212	1	SEEGER E12 LEVA CAMBIO	CIRCLIP D.12 - EXTERNAL
3	04004	1	PARAOLIO POMPA H2O-LEVA CAMBIO	OIL SEAL 12 x 22 x 5
5	F33314	2	FORCHETTA A/S 125/250/300 CROM	SHIFT FORK SECONDARY 125/250CR
6	33256	1	PERNO FORCH.ALB.SEC. 250 / 125.99	AXEL, COUNTERSHAFT FORK 250cc
7	33004	1	ALBERO DESM.125 INTEGR. 6M CPL 125/144 6 M. CPL DI F26476	GEAR DRUM 125 6SP. 125/144 ASSY F26476
8	33016	1	FORCHETTA ALB.PRIM.125 PRT.CRM	SHIFT FORK MAINSHAFT 125 CROM.
9	33255	1	PERNO FORCH.ALB. PRIM.250 / 125.99	AXEL, MAINSHAFT FORK 250cc
10	49485	1	VITE TCEI 6X25 UNI 5931	BOLT TCEI 6x25
11	16252.12	1	MOLLA BLOCCAMARCE 125/250 2012	SPRING, STOP GEAR 125/250 M.12
12	26007	1	DISTANZIALE MOLLA BLOCCAMARCE	SPACER, STOP GEAR SPRING
13	26063.12	1	PIASTRINO BLOCCAMARCE 2012 CPL	PLATE STOP GEAR ASSY M.12->
14	49368	1	VITE TE F/R 6X10 LEVA M/M	BOLT 6X10 (Kich Starter)
16	43038	1	LEVA M/M 80/125 M. 99/->	LEVER, KICK STARTER 125 99/->
17	26005	1	DISTANZIALE MOLLA M/M	SPACER, KICK STARTER SPRING
18	16008	1	MOLLA M/M 80 / 125 / 144 cc	SPRING, KICK STARTER
19	48008	1	RONDELLA ALBERO MESSA IN MOTO	WASHER, KICK STARTER SHAFT
20	28051	1	ALBERO MESSA IN MOTO 125/144 96/18	SHAFT, KICK STARTER 125 96/05
21	40350	1	INGRANAGGIO SCORREVOLE M/M 125 / 144	SLIDING GEAR, KICK STARTER 125
22	26254	1	LEVA BATTUTA M/M 125/250 96/->	STOPPER, KICK STARTER
23	16006	1	MOLLA X INGRANAGGIO M/M	SPRING, KICKSTART SLIDING GEAR
24	49214	1	SEEGER E15 INGRANAGGIO M/M	CIRCLIP GEAR K.S. 15mm
25	49638	1	DADO M 6 ALTO AUTOBLOCCANTE	NUT 6mm, HIGHT SELF-LOCKING
26	49603	1	RONDELLA M 6,4 X 12 X 1,6	WASHER 6x12
27	28100	1	ALBERO COMANDO ING. P.TACRIC.	SHAFT, GEARSHIFT
28	26050	1	BATTUTA ECCENTRICA	ADJUSTER SELECTOR SHAFT
29	16009	1	MOLLA RITORNO LEVA CAMBIO 32CR	SPRING, RETURN GEAR LEVER 3,2
30	26006	1	DISTANZIALE MOLLA LEVA CAMBIO	SPACER, GEAR LEVER SPRING



2T144EN24-M
MOTORE - ENGINE

FORCHETTE CAMBIO
GEAR FORKS

31	49405	2	VITE TSEI 6X20 UMB.5933 10.9	BOLT TSEI 6x20 U.5933 10.9
32	26022	1	PIASTRINO FINE CORSA	PLATE END STROKE GEAR LEVER
33	26051	1	BATTUTA FISSA LEVA CAMBIO INT.	PLATE INT. END STROKE GEAR LEVER
34	49483	2	VITE TCEI 6X16 UNI 5931	BOLT TCEI 6X16
35	26021	1	PIASTRINO RIENTRO CRICCHETTI	PLATE, RATCHET
36	26060	1	CRICCHETTO CAMBIO SUPERIORE	RATCHET UP, GEAR
37	26061	1	CRICCHETTO CAMBIO INFERIORE	RATCHET DOWN, GEAR
38	26062	2	PUNTALE PER CRICCHETTO CAMBIO	PIN, RATCHET GEAR
39	16012	2	MOLLA PER PUNTALE	SPRING, GEARBOX PIN
40	40310	1	INGRANAGGIO PORTACRICCHETTI	DRUM SHIFTER GEAR

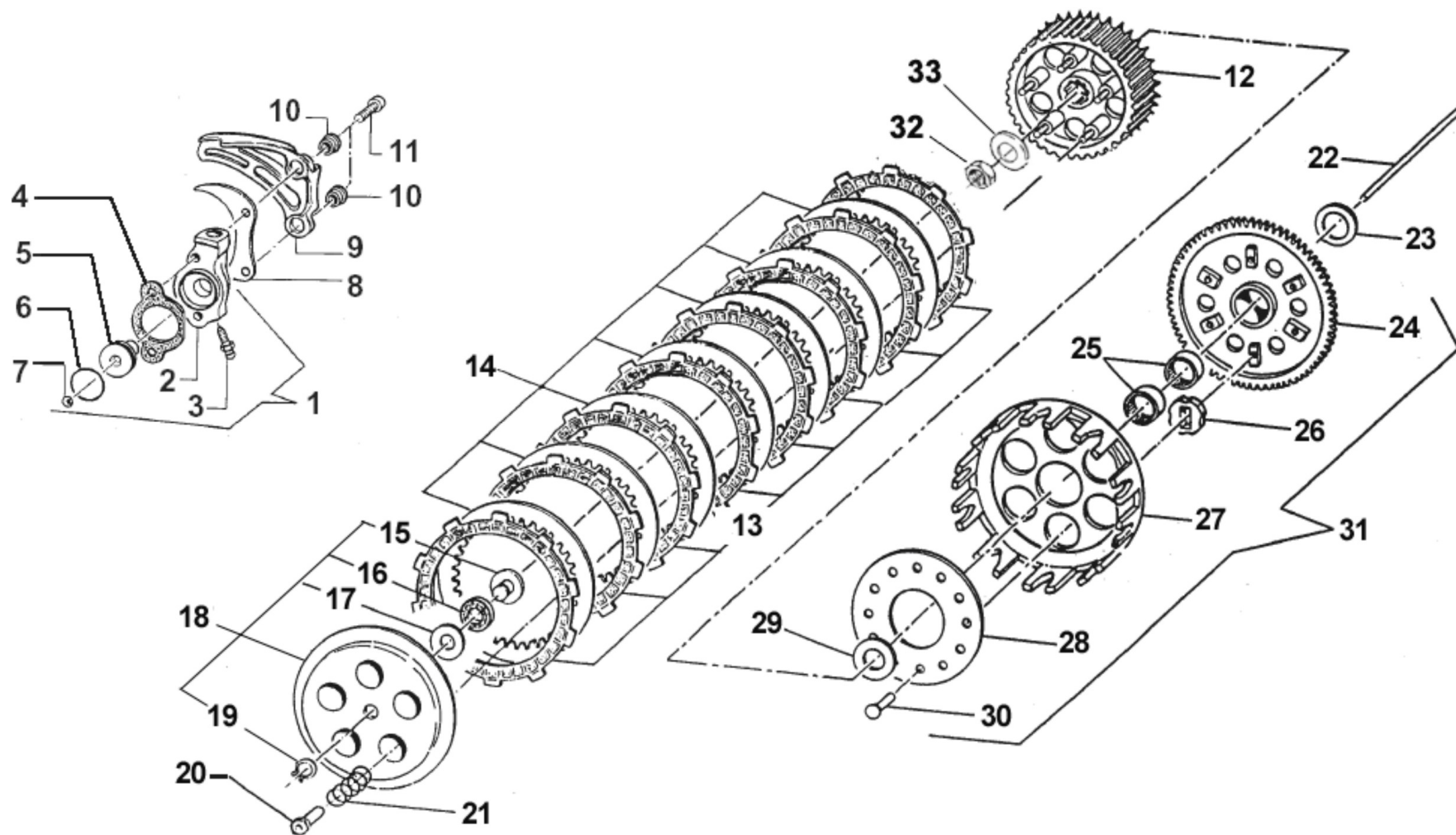



2T144EN24-M
MOTORE - ENGINE

FRIZIONE
CLUTCH

1	30206	1	COP. FRIZ/IDR 85/125 95/-> CPL	OUTPUT H.CLUTCH CYLINDER CPL.
2	30205	1	COP. FRIZ/IDR 80/125 95/11 NUD	OUTPUT H.CLUTCH CYLINDER
3	35264	1	VITE SPURGO OLIO FRIZ.IDR.6X1	SCREW AIR BLED HYDRAUL.CLUTCH
4	05509	1	GUARN. POMPA FRIZ.IDR. 80/125	GASKET, HYDRAULIC CLUTCH80/125
5	35125	1	PISTONE POMPA FRIZ. 125 95/->	PISTON, CLUTCH PUMP 125 95/04
6	12259	1	O RING PISTONE FR.125/250 VITON (Verde)	O-RING, CLUTCH PISTON 125/250
7	19052	1	SFERA 8 X FRIZIONE 250 5/16"	BALL, IDR. CLUTCH PUMP
8	40022	1	PROTEZIONE ERGAL PIGNONE CAT.	PROTECTION, GEAR CHAIN ERGAL
9	40029	1	PROTEZIONE PIGNONE 09/-> PLAST	PROTECTION FRONT SPROCKET09/13
10	26212	2	BOCCOLA PROT. PIGNONE 125 F.6	COLLAR, SPROCKET 125cc H.6
11	49486	2	VITE TCEI 6X30 UNI 5931	BOLT TCEI 6X30
12	25099.14	1	TAMBURELLO FRIZIONE 125 2014	CLUTCH CENTRE 125cc M.14->
12	50124	1	CHIAVE FRIZ. 85/125 + KART CPL	CLUTCH TOOL 85/125cc + KART
13	35012	8	DISCO FRIZ. GUARN.CR/E M.93->	CLUTCH PLATE, FIBER 85/125 MX/E 93/->
14	35019	7	DISCO FRIZ. ACC. 1mm 99/05	CLUTCH PLATE, STEEL 1mm 99/05
15	26001	1	REGGISPINTA FRIZIONE	CLUTCH THRUST
16	19020	1	GABBIA A RULLI RAD. AXK 1024	NEEDLE CAGE AXK 1024, RADIAL
17	19021	1	RONDELLA X GABBIA RULLI AS1024	WASHER, NEEDLE CAGE AS 1024
18	35025	1	PIATTO SPING.FRIZ 125/KART CPL	PLATE, CLUTCH PRESSURE ASSY
19	49211	1	SEEGER E10x1 ANELLO PIATT.REG.	CIRCLIP D.8,4 - EXTERNAL
20	49057	5	DADO FRIZIONE ERGAL 125/144	NUT, CLUTCH KZ10 ERGAL
21	16020	5	MOLLA FRIZIONE 125 C/E 03/08BA	SPRING, CLUTCH 125 MX/E 03/->
22	35043	1	ASTINA FRIZ. IDR. 125 M.99/10	ROD, HYDR.CLUTCH 125 M. 99/04
23	48003	1	SPESSORE COP.PRIM.30X20X2	SPACER 30X20X2 PRIMARY GEAR
24	40402	1	COPPIA PRIM. 125 Z63	PRIMARY GEAR 63T, 125cc
25	19013	2	GABBIA A RULLI K 20X24X12	NEEDLE CAGE 20 X 24 X 12
26	21005	6	GOMMINO PARASTRAPPI FRIZIONE	RUBBER, CLUTCH BASKET
27	25000	1	CAMPANA FRIZ.125 M.91/96 99/23	CLUTCH BASKET 125 91/96 99/05



2T144EN24-M
MOTORE - ENGINE

FRIZIONE
CLUTCH

28	35026	1	DISCO BATTUTA GOMM. FRIZ.KZ10B 85/125	DISC STOP RUBBERS CLUTCH KZ10B
29	48002	1	SPESSORE COP.PRIM.30X18X3	SPACER 30x18x3
30	49727	6	VITE PARASTRAPPI K9 M7X1X12.5	SCREW, M7X1X12,5 K9 ENGINE
31	40409	1	COPPIA PRIM. 125 Z63 CPL 99/-> 93/96	PRIM.GEAR 63T,125 Comp. 99/04
32	49052	1	DADO TAMBURELLO FRIZIONE	NUT, CLUTCH CENTER
33	49127	1	MOLLA A TAZZA DIN 2093 28X14,2X1,25	DISC SPRING DIN 2093 28x14,2x1,25

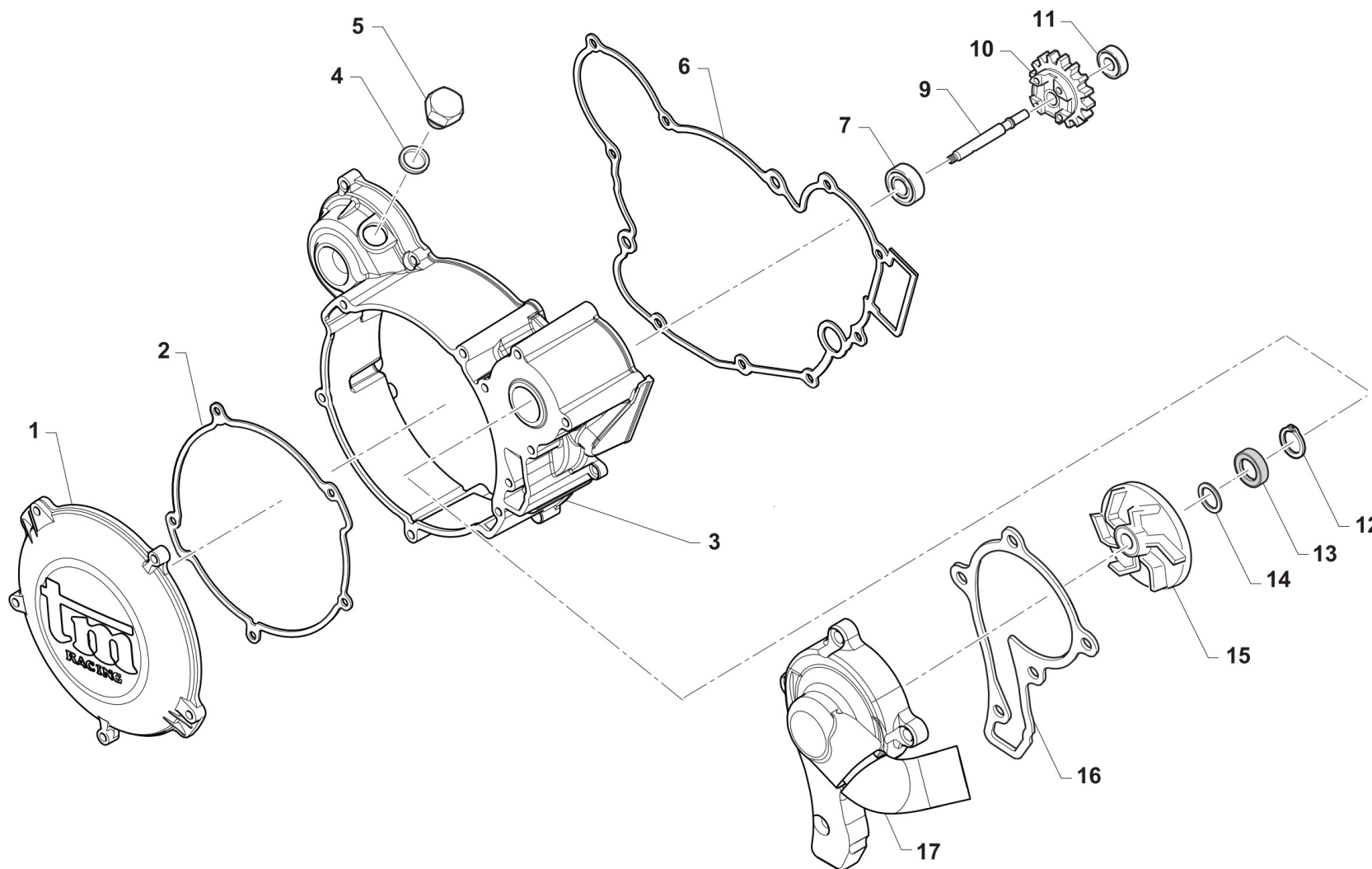



2T144EN24-M
MOTORE - ENGINE

COPERCHI FRIZIONE E CENTRIFUGA

1	30187	1	COPERCHIETTO FRIZ. 125 M.2006	COVER, CLUTCH, EXT. 125 06/->
2	05526	1	GUARN. COP.FRIZ. EST.125 06/->	GASKET, EXT.CLUTCH COVER 125/6
3	30174	1	CARTER FRIZIONE 125 M.12/->	CLUTCH COVER 125 M.12->
4	49103	1	RONDELLA 14X20X1,5 ALLUMINIO	WASHER, 14 X 20 X 1.5 ALUMINUM
5	49300	1	TAPPO CARICO OLIO	OIL PLUG, FILL
6	05527	1	GUARN. COP.FRIZ. INT.125 06/->	GASKET, CLUTCH CASE 125 06/->
7	03014	1	CUSCINETTO 608 ZC3 POMPA SCHER	BUSH, WATER PUMP 608 Z C3
9	28062	1	ALBERINO POMPA ACQUA 125 2012	SHAFT, WATERPUMP 125 M.12/->
10	40071	1	INGR COMANDO POMPA H2O 125 '12	GEAR, WATERPUMP 125 M.12/->
11	03025	1	CUSCINETTO 626 C3 POMPA H2O 06	BUSH, WATER PUMP 626 C3
12	49215	1	SEEGER I22 POMPA ACQUA	CIRCLIP D.22 WATER PUMP
13	04017	1	PARAOLIO CENTRIFUGA 06	OIL SEAL 8 X 22 X 7 TC
14	49689	1	RONDELLA 6 X 12 SP. 1.2	WASHER 6x12 sp. 1,2
15	28009	1	GIRANTE POMPA ACQUA 2006/08	IMPELLER, WATER PUMP M.06/->
16	05528	1	GUARN. POMPA ACQUA 125 2006	GASKET WATER PUMP 125cc 2006
17	30194.20	1	COPERCHIO POMPA H2O 125/144 maggiorato	

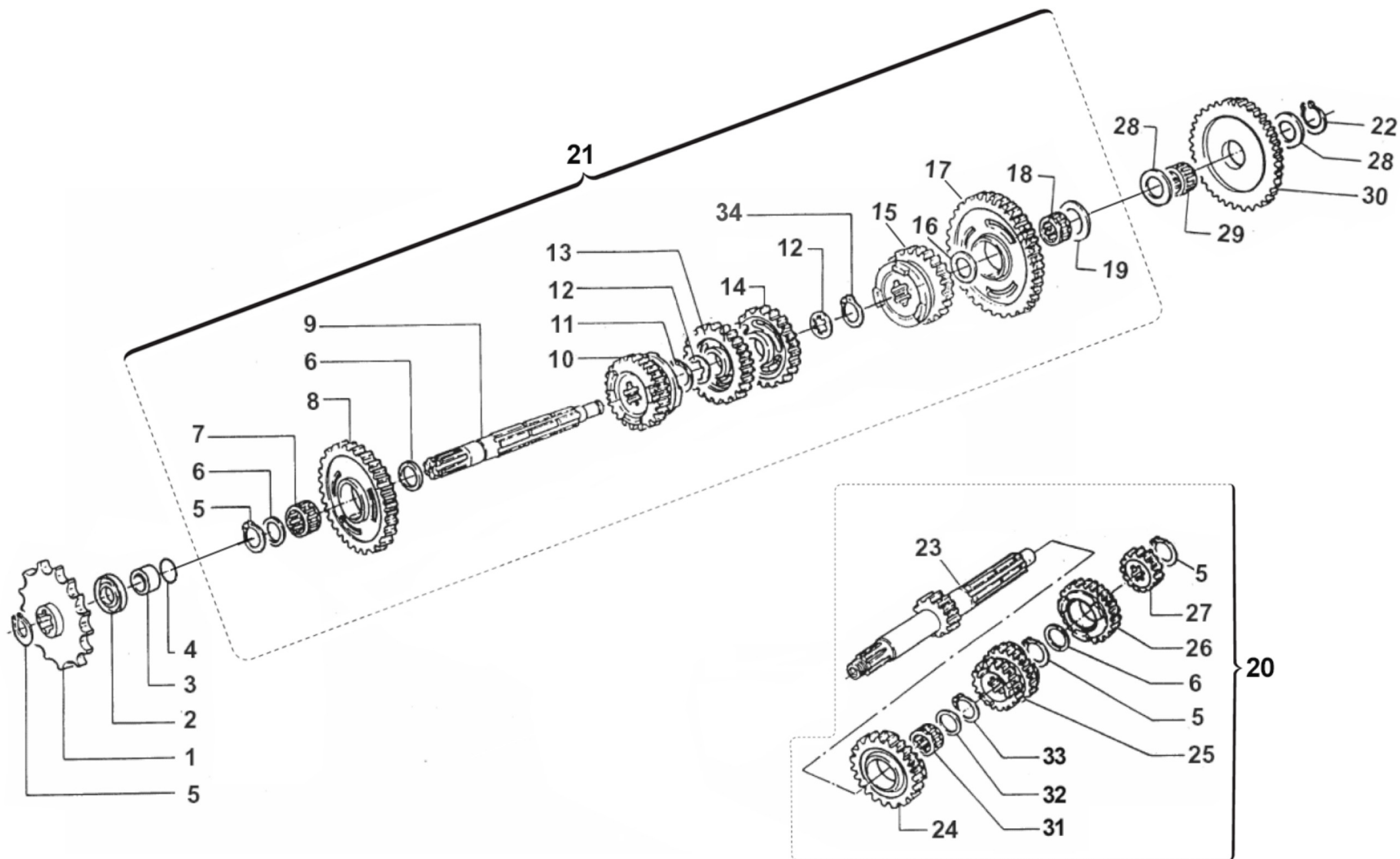



2T144EN24-M
MOTORE - ENGINE

CAMBIO ENDURO
GEARBOX EN

1	40024	1	PIGNONE CAT. Z 11 BR12 M.00/->	SPROCKET 11T, DRIVE M.00/10
1	40025	1	PIGNONE CAT. Z 12 BR12 M.00/->	SPROCKET 12T, DRIVE 125 00/->
1	40026	1	PIGNONE CAT. Z 13 BR12 M.00/->	SPROCKET 13T, DRIVE 125 00/->
2	04003	1	PARAOLIO PIGN.CATENA (26x37x7)	OIL SEAL 26 x 37 x 7
3	26002.1	1	DISTANZIALE PIGNONE (MOTO)	SPACER, MOTORCYCLE GEAR
4	12019	1	O RING PIGNONE CATENA	O-RING, DRIVE GEAR 2075
5	49216	4	SEEGER E20 PIGN.-CAMBIO-COPPIA	CIRCLIP D.20 - EXTERNAL
6	48013	3	RASAMENTO A/S 27X20X0,7	SPACER, 27x20x0,7
7	19012	1	GABBIA A RULLI K 20X24X10	BUSH NEEDLE CAGE 20 X 24 X 10
8	40708	1	INGR A.S. 2a Z 29 CR/E 90	GEAR, 2TH (29T) COUNTERSH.CR/E
9	40462	1	ALBERO SECONDARIO SCAN. 12	COUNTERSHAFT BR 12
10	40456	1	INGR A.S. 6a Z 24 END 144CC	GEAR, 6TH (24T) COUNTERSHAFT E
11	49217	1	SEEGER E22 ANELLO ALB/S	CIRCLIP D.22 - COUNTERSHAFT
12	48011	2	RASAMENTO DENT.A/S 27X22X0,75	SPACER, 27x22x0,75
13	40710	1	INGR A.S. 4a Z 25 CR/E 90	GEAR, 4TH(25T)COUNTERSH.MX/E90
14	40709	1	INGR A.S. 3a Z 27 CR/E 90	GEAR, 3RD(27T)COUNTERSH.MX/E90
15	40510	1	INGR A.S. 5a Z 24 CR/E 90	GEAR, 5TH (24T) COUNTERSHAFT
16	48012	1	RASAMENTO A/S M/M SPESS.0,5	SPACER, 26x17x0,5
17	40706	1	INGR A.S. 1a Z 32 END/90	GEAR, 1ST(32T)COUNTERSH.END/90
18	19011	1	GABBIA A RULLI K 17X21X10	BUSH CAGE 17 X 21 X 10
19	48010	1	RASAMENTO ALB/S.28X15X0,5 INGI	SPACER, 28x15x0,5
20	40039	1	ALBERO PRIM. CPL 144 END 09/->	PRIMARY SHAFT 144 EN ASSY
21	40036	1	ALBERO SECOND.CPL 144 EN.09/->	SECONDARY SHAFT 144 EN ASSY
22	49214	1	SEEGER E15 INGRANAGGIO M/M	CIRCLIP GEAR K.S. 15mm
23	40714	1	ALBERO PRIMARIO Z 13 END.RINF.	MAINSHAFT 13T END. REINFORCED
24	40440	1	INGR. A.P. 5a Z 22 K9B/C 10 CR/E90	GEAR, 5TH (22T) MAINSHAFT
25	40702	1	INGR A.P. 3/4a Z 18/20 CR/E 90	GEAR, 3/4TH(18/20T)MAINSH.MX/E
26	40455	1	INGR A.P. 6a Z 27 END 144CC	GEAR, 6TH (27T) MAINSHAFT END. 144cc



2T144EN24-M
MOTORE - ENGINE

CAMBIO ENDURO
GEARBOX EN

27	40701	1	INGR A.P. 2a Z 16 CR/E 90	GEAR, 2ND (16T) MAINSH.MX/E 90
28	48004	2	SPESSORE INGRANAGGIO M/M	SPACER, K.STARTER GEAR
29	19010	1	GABBIA A RULLI K 15X19X10	BUSH NEEDLE CAGE 15 X 19 X 10
30	40351	1	INGRANAGGIO LIBERO M/M 125 / 144	GEAR, KICK STARTER 125
31	19071	1	GABBIA A 20X24X10 IN DUE META'	NEEDLE CAGE 20X24X10 TWO PIEC.
32	48041	1	RASAMENTO A/P 27.5X21X1 KZ10B	SPACER, MAINSHAFT 27,5X21X1 KZ
33	49222	1	SEEGER E 21 mm	CIRCLIP D.21 - EXTERNAL
34	49217.1	1	SEEGER RETTIFICATO PER 40510	SEEGER RING FOR CODE 40510



2T144EN24-M
MOTORE - ENGINE

VITI COPERCHI

12

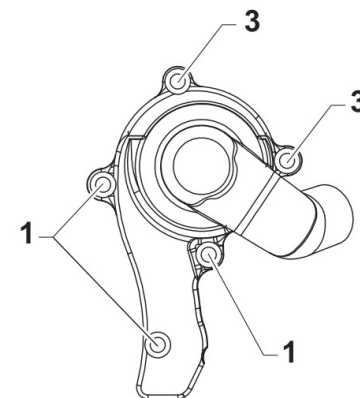
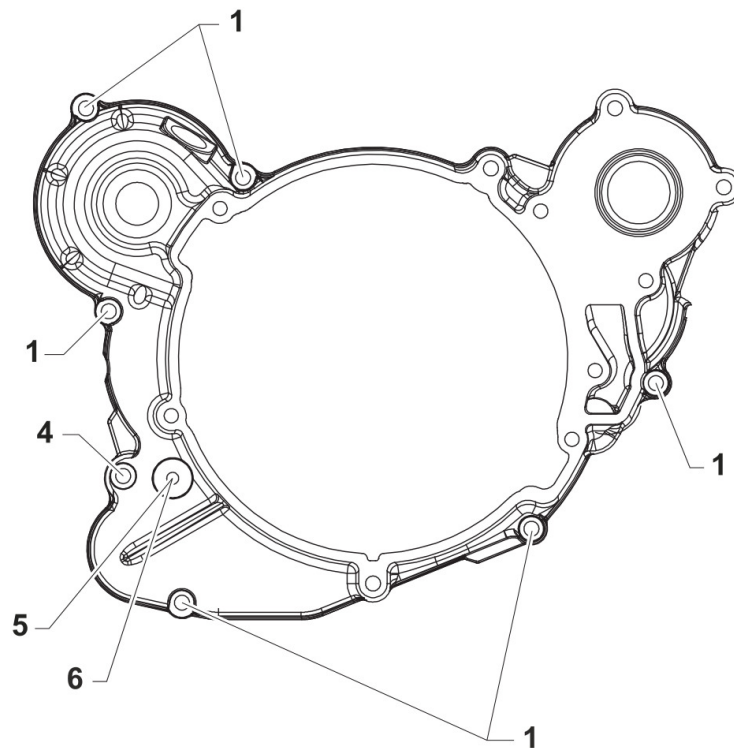
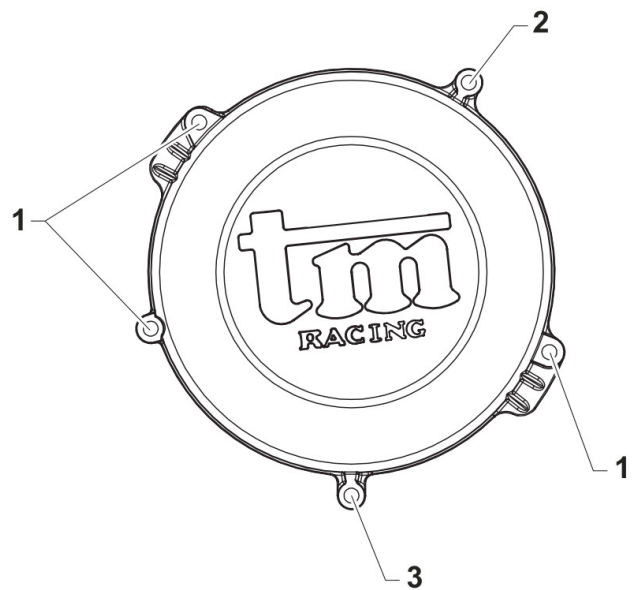

0181



2T144EN24-M
MOTORE - ENGINE

VITI COPERCHI

12

1	49476	12	VITE TCEI 5X20 UNI 5931	BOLT TCEI 5X20
2	49563	1	VITE TCEI 6X85	SCREW TCEI 6X85
3	49595	3	VITE TCEI 5X80 UNI 5931-912 Brun	BOLT TCEI 5X80
4	49477	1	VITE TCEI 5X25 UNI 5931-912	BOLT TCEI 5X25
5	49480	1	VITE TCEI 6X10 UNI 5931	BOLT TCEI 6X10
6	49104	1	RONDELLA 6 x 10 x 1,5 ALLUMINIO	WASHER 6 x 10 x 1.5 ALUMINUM



2T144EN24-M
MOTORE - ENGINE

VITI BASAMENTO

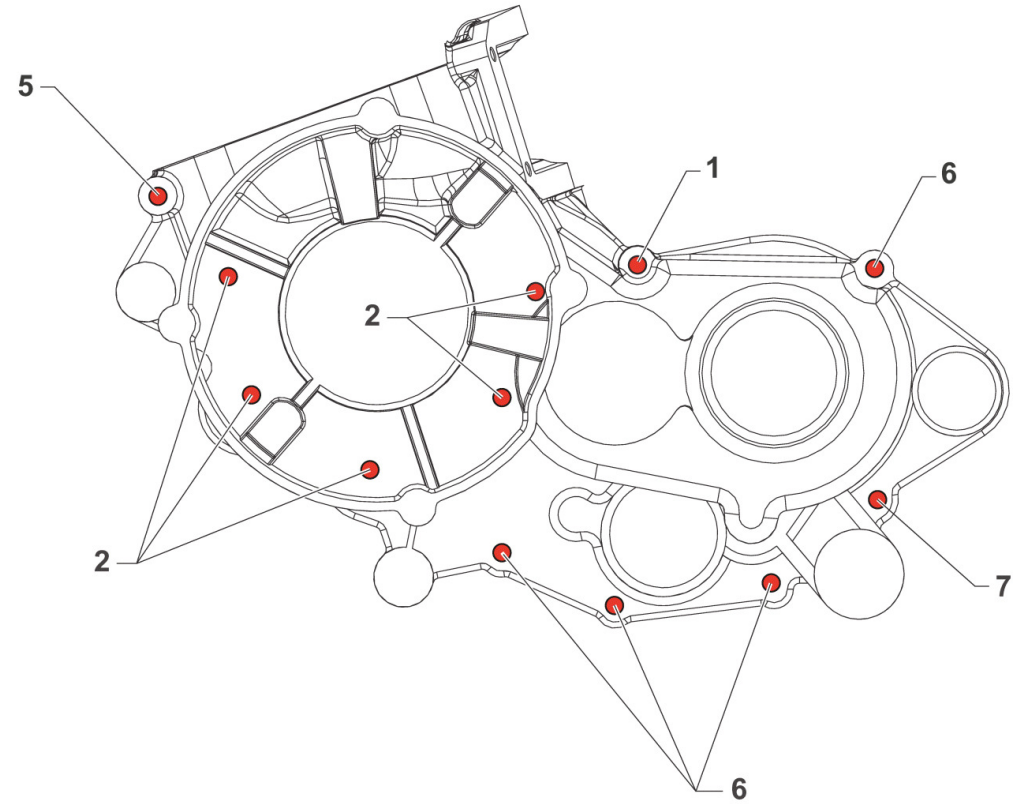
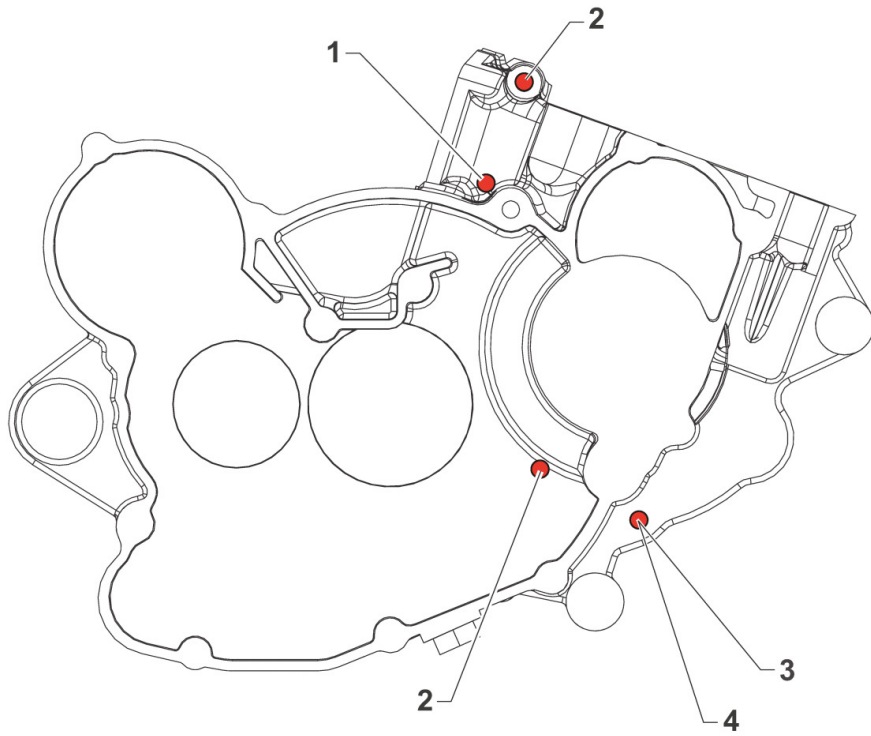



2T144EN24-M
MOTORE - ENGINE

VITI BASAMENTO

1	49491	2	VITE TCEI 6X55	BOLT TCEI 6X55
2	49489	7	VITE TCEI 6X45 UNI 5931	BOLT TCEI 6x45
3	49104	1	RONDELLA 6 x 10 x 1,5 ALLUMINIO	WASHER 6 x 10 x 1.5 ALUMINUM
4	49480	1	VITE TCEI 6X10 UNI 5931	BOLT TCEI 6X10
5	49490	1	VITE TCEI 6X50 UNI 5931	BOLT TCEI 6X50
6	49487	4	VITE TCEI 6X35 UNI 5931	BOLT TCEI 6X35
7	49488	1	VITE TCEI 6X40	BOLT TCEI 6x40



2T144EN24-M
MOTORE - ENGINE

-

01133	2T14420-M-01	14	1
01134	2T14420-M-01	1	1
02025	2T14420-M-01	2	1
03009	2T14419-M-05	5	2
03010	2T14419-M-05	8	1
03011	2T14419-M-05	4	1
03012	2T14419-M-05	6	1
03014	2T125AA20-M-08	7	1
03025	2T125AA20-M-08	11	1
03026	2T14419-M-03	16	1
03156	2T14420-M-01	18	1
03255	2T14419-M-03	18	1
04003	2T14419-M-05	7	1
	2T144EN17-M-09	2	1
04004	2T125EN20-M-06	3	1
04017	2T125AA20-M-08	13	1
04034.15	2T14419-M-05	3	1
04035	2T14419-M-03	15	2
04115	2T14420-M-01	15	1
05277	2T14419-M-05	20	1
05509	2T12520-M-07	4	1
05516	2T144EN22-M-04	7	1
05526	2T125AA20-M-08	2	1
05527	2T125AA20-M-08	6	1
05528	2T125AA20-M-08	16	1
05530	2T14420-M-01	9	1
05531	2T14420-M-01	9	1
05532	2T14420-M-01	9	1

05533	2T14420-M-01	9	1
05534	2T14420-M-01	9	1
05535	2T14420-M-01	9	1
05621	2T14419-M-05	2	1
06011	2T14420-M-01	7	1
09004.1	2T14419-M-03	3	2
09008	2T14419-M-03	4	1
10023.94	2T14419-M-03	1	1
10023.95	2T14419-M-03	1	1
11065	2T14419-M-03	2	2
12003	2T14420-M-01	3	1
12019	2T144EN17-M-09	4	1
12021	2T14420-M-01	4	1
12026	2T14419-M-05	27	1
12042	2T12522-M-02	10	1
12259	2T12520-M-07	6	1
13009	2T14419-M-05	24	1
13081	2T14420-M-01	28	1
13086	2T14419-M-05	23	1
15100	2T144EN22-M-04	10	1
15102	2T144EN22-M-04	9	1
15103	2T144EN22-M-04	4	1
15230	2T144EN22-M-04	1	1
16006	2T125EN20-M-06	23	1
16008	2T125EN20-M-06	18	1
16009	2T125EN20-M-06	29	1
16012	2T125EN20-M-06	39	2
16020	2T12520-M-07	21	5

16066	2T14420-M-01	26	1
16252.12	2T125EN20-M-06	11	1
17074	2T14419-M-03	8	1
18079	2T14419-M-03	7	1
18144	2T14419-M-03	9	1
18145	2T14419-M-03	10	1
18177.13	2T14419-M-03	11	1
18178.13	2T14419-M-03	12	1
18248	2T14419-M-03	6	2
19010	2T144EN17-M-09	29	1
19011	2T144EN17-M-09	18	1
19012	2T144EN17-M-09	7	1
19013	2T12520-M-07	25	2
19020	2T12520-M-07	16	1
19021	2T12520-M-07	17	1
19034	2T14419-M-03	5	1
19041	2T14419-M-05	11	1
19052	2T12520-M-07	7	1
19060	2T14420-M-01	13	1
19061	2T14420-M-01	33	1
19071	2T144EN17-M-09	31	1
20061	2T14419-M-05	22	1
20074	2T14419-M-05	21	1
21005	2T12520-M-07	26	6
21009	2T12522-M-02	19	1
21017	2T14420-M-01	6	1
22147	2T14420-M-01	31	1
22500	2T12522-M-02	20	1



2T144EN24-M
MOTORE - ENGINE

-

22502.20	2T12522-M-02	21	1
25000	2T12520-M-07	27	1
25099.14	2T12520-M-07	12	1
26001	2T12520-M-07	15	1
26002.1	2T144EN17-M-09	3	1
26005	2T125EN20-M-06	17	1
26006	2T125EN20-M-06	30	1
26007	2T125EN20-M-06	12	1
26021	2T125EN20-M-06	35	1
26022	2T125EN20-M-06	32	1
26023	2T14419-M-05	14	1
26043	2T14419-M-05	10	1
26044	2T14419-M-05	9	3
26050	2T125EN20-M-06	28	1
26051	2T125EN20-M-06	33	1
26060	2T125EN20-M-06	36	1
26061	2T125EN20-M-06	37	1
26062	2T125EN20-M-06	38	2
26063.12	2T125EN20-M-06	13	1
26130.12	2T14420-M-01	29	1
26130.13	2T14420-M-01	29	1
26130.14	2T14420-M-01	29	1
26130.15	2T14420-M-01	29	1
26130.16	2T14420-M-01	29	1
26130.17	2T14420-M-01	29	1
26130.18	2T14420-M-01	29	1
26130.19	2T14420-M-01	29	1
26147	2T14420-M-01	30	1

26167	2T14420-M-01	34	1
26168	2T14420-M-01	24	1
26212	2T12520-M-07	10	2
26254	2T125EN20-M-06	22	1
26258	2T14420-M-01	16	1
28009	2T125AA20-M-08	15	1
28051	2T125EN20-M-06	20	1
28059	2T14420-M-01	32	1
28062	2T125AA20-M-08	9	1
28100	2T125EN20-M-06	27	1
28108	2T14420-M-01	21	1
28109	2T12522-M-02	9	1
28263	2T14420-M-01	23	1
28266.0	2T12522-M-02	5	1
28266.1	2T12522-M-02	5	1
30174	2T125AA20-M-08	3	1
30177.19	2T14419-M-05	1	1
30187	2T125AA20-M-08	1	1
30194.20	2T125AA20-M-08	17	1
30205	2T12520-M-07	2	1
30206	2T12520-M-07	1	1
30210	2T144EN22-M-04	11	1
30217	2T14420-M-01	11	1
30291	2T12522-M-02	1	1
30392	2T12522-M-02	2	1
33004	2T125EN20-M-06	7	1
33016	2T125EN20-M-06	8	1
33255	2T125EN20-M-06	9	1

33256	2T125EN20-M-06	6	1
35012	2T12520-M-07	13	8
35019	2T12520-M-07	14	7
35025	2T12520-M-07	18	1
35026	2T12520-M-07	28	1
35043	2T12520-M-07	22	1
35125	2T12520-M-07	5	1
35264	2T12520-M-07	3	1
40022	2T12520-M-07	8	1
40024	2T144EN17-M-09	1	1
40025	2T144EN17-M-09	1	1
40026	2T144EN17-M-09	1	1
40029	2T12520-M-07	9	1
40036	2T144EN17-M-09	21	1
40039	2T144EN17-M-09	20	1
40071	2T125AA20-M-08	10	1
40303	2T14419-M-03	14	1
40310	2T125EN20-M-06	40	1
40350	2T125EN20-M-06	21	1
40351	2T144EN17-M-09	30	1
40402	2T12520-M-07	24	1
40409	2T12520-M-07	31	1
40440	2T144EN17-M-09	24	1
40455	2T144EN17-M-09	26	1
40456	2T144EN17-M-09	10	1
40462	2T144EN17-M-09	9	1
40510	2T144EN17-M-09	15	1
40701	2T144EN17-M-09	27	1



2T144EN24-M
MOTORE - ENGINE

-

40702	2T144EN17-M-09	25	1
40706	2T144EN17-M-09	17	1
40708	2T144EN17-M-09	8	1
40709	2T144EN17-M-09	14	1
40710	2T144EN17-M-09	13	1
40714	2T144EN17-M-09	23	1
43038	2T125EN20-M-06	16	1
43049	2T125EN20-M-06	1	1
48002	2T12520-M-07	29	1
48003	2T12520-M-07	23	1
48004	2T144EN17-M-09	28	2
48008	2T125EN20-M-06	19	1
48010	2T144EN17-M-09	19	1
48011	2T144EN17-M-09	12	2
48012	2T144EN17-M-09	16	1
48013	2T144EN17-M-09	6	3
48041	2T144EN17-M-09	32	1
490021	2T12522-M-02	17	5
49009	2T14419-M-05	16	1
49010	2T14419-M-03	17	1
49052	2T12520-M-07	32	1
49057	2T12520-M-07	20	5
49059	2T14419-M-05	18	2
49061	2T144EN22-M-04	6	1
49094	2T14419-M-03	13	1
49103	2T125AA20-M-08	4	1
	2T14419-M-05	12	1
49104	2T125FI20-M-12	6	1

	2T125FI20-M-13	3	1
49124	2T12522-M-02	12	1
49127	2T12520-M-07	33	1
49161	2T14419-M-05	17	2
49211	2T12520-M-07	19	1
49212	2T125EN20-M-06	2	1
49214	2T125EN20-M-06	24	1
	2T144EN17-M-09	22	1
49215	2T125AA20-M-08	12	1
49216	2T144EN17-M-09	5	4
49217	2T144EN17-M-09	11	1
49217.1	2T144EN17-M-09	34	1
49220	2T14420-M-01	19	1
49222	2T144EN17-M-09	33	1
49300	2T125AA20-M-08	5	1
49301	2T14419-M-05	13	1
49355	2T14420-M-01	27	3
49358	2T14420-M-01	5	6
49368	2T125EN20-M-06	14	1
49399	2T14420-M-01	10	1
49405	2T125EN20-M-06	31	2
49440	2T14419-M-05	15	2
49470	2T144EN22-M-04	8	2
49472	2T12522-M-02	3	1
49476	2T125FI20-M-12	1	12
49477	2T125FI20-M-12	4	1
	2T144EN22-M-04	12	4
49478	2T12522-M-02	18	4

49480	2T125FI20-M-12	5	1
	2T125FI20-M-13	4	1
49483	2T125EN20-M-06	34	2
49484	2T14419-M-05	26	4
	2T144EN22-M-04	3	2
49485	2T125EN20-M-06	10	1
49486	2T12520-M-07	11	2
49487	2T125FI20-M-13	6	4
49488	2T125FI20-M-13	7	1
49489	2T125FI20-M-13	2	7
49490	2T125FI20-M-13	5	1
49491	2T125FI20-M-13	1	2
49563	2T125FI20-M-12	2	1
49595	2T125FI20-M-12	3	3
49603	2T125EN20-M-06	26	1
	2T144EN22-M-04	2	2
49618	2T144EN22-M-04	5	1
49630	2T14420-M-01	20	1
49632	2T12522-M-02	6	2
49638	2T125EN20-M-06	25	1
49640	2T14419-M-05	19	4
	2T14420-M-01	8	4
49676	2T14420-M-01	35	1
49689	2T125AA20-M-08	14	1
49727	2T12520-M-07	30	6
49757	2T14420-M-01	17	1
49874	2T14420-M-01	22	1
49881	2T12522-M-02	13	1



2T144EN24-M
MOTORE - ENGINE

-

49929	2T12522-M-02	7	1
49973	2T12522-M-02	15	4
50030	2T14419-M-03	14	1
50051	2T144EN22-M-04	1	1
50124	2T12520-M-07	12	1
51054	2T14419-M-05	25	2
72251	2T12522-M-02	8	2
F12301	2T12522-M-02	11	2
F12308	2T14420-M-01	12	1
F19536	2T14420-M-01	25	1
F33314	2T125EN20-M-06	5	2