



USES AND
RACOMMENDS



www.tmracing.it

TM Racing SpA - Via Fano, 6
61122 Pesaro - ITALY
Phone: +39 0721 25113

2T125MX25-M

2T 125 MX ES
ENGINE

19/11/2024



INFORMAZIONI GENERALI

Il presente catalogo serve per richiedere con esattezza le parti di ricambio.

Nelle ordinazioni indicare:

1) Il numero di matricola del Telaio che è stampigliato sul lato destro del canotto di sterzo. Nei modelli EN, SMR, SMR il numero di matricola è riportato anche su una targhetta posta sul lato sinistro (Vedi foto).

2) il numero di serie del Motore. E' posto sulla sinistra del motore tra la leva cambio e i coperchio accensione (Vedi foto).

3) Il codice dei particolari seguito dalla descrizione.

4) Il colore per i pezzi verniciati o comunque colorati.

Le indicazioni destra e sinistra si riferiscono ai lati del veicolo rispetto al senso di marcia.

Foto e disegni sono solo a scopo informativo e potrebbero non corrispondere esattamente alle caratteristiche dei prodotti.

GENERAL INFORMATION

The present spare parts catalogue enables one to order exactly the right spare part.

When ordering specify:

1) The frame serial number. It is embossed on the right side of the steering metal tube. In the EN, SMR and SMR models, the serial number is also stated on a plate positioned on the left hand side (See photo).

2) The engine serial numer. It is located on the left side of the engine between the gear lever and the ignition cover (See photo).

3) The part's code number followed but its description.

4) Indicate colour for painted or colored parts.

References to right and left apply to the vehicle in terms of its direction of movement.

Photos and drawings are for informational purposes only and may not exactly match the characteristics of the products.

NOTE – LEGENDA

MY

NOVITA' INTRODOTTA DIFFERENTE O NON PRESENTE NEL MODELLO DELL'ANNO PRECEDENTE

PART DIFFERENT OR NOT PRESENT IN THE REVIOUS YEAR MODEL

5M

MOTORE CON CAMBIO A 5 MARCE
ENGINE WITH 5 GEARS SPEED

6M

MOTORE CON CAMBIO A 6 MARCE
ENGINE WITH 6 GEARS SPEED

KS

MOTORE CON SOLO KICK STARTER
ENGINE WITH KICK STARTER ONLY

ES

MOTORE CON AVVIAMENTO ELETTRICO
ENGINE WITH ELECTRIC STARTER

X

RICAMBIO NON DISPONIBILE ALLA VENDITA
PART CAN NOT BE SOLD SEPARATELY



Le illustrazioni riportate in questo manuale sono fornite solo come riferimento e possono variare dal prodotto effettivo,

Dati indicativi soggetti a modifiche senza impegno di preavviso.

The illustrations in this manual are for reference only and may vary from the actual product.

All data are subject to modification without prior notice.



2T125MX25-M
2T 125 MX ES - ENGINE

SOMMARIO
TABLE OF CONTENTS

CILINDRO 01 - 125 MX/EN CARB. - CYLINDER 01 - 125 MX/EN CARB.....	4
CILINDRO 02 - 125 MX/EN CARB. - CYLINDER 02 - 125 MX/EN CARB.....	6
ALBERO MOTORE E PISTONE - CRANKSHAFT AND PISTON.....	9
ACCENSIONE CARBURATORE.....	11
FRIZIONE - CLUTCH.....	13
CARTER FRIZIONE - CLUTCH CASE.....	16
BASAMENTO E PACCO - CASE AND REEDS BOX.....	18
COMANDO CAMBIO - GEARSHIFT MECHANISM.....	20
CAMBIO MX - GEARBOX MX.....	23
VITI MOTORE - BOLTS.....	26



2T125MX25-M
2T 125 MX ES - ENGINE

CILINDRO 01 - 125 MX/EN CARB.
CYLINDER 01 - 125 MX/EN CARB

1

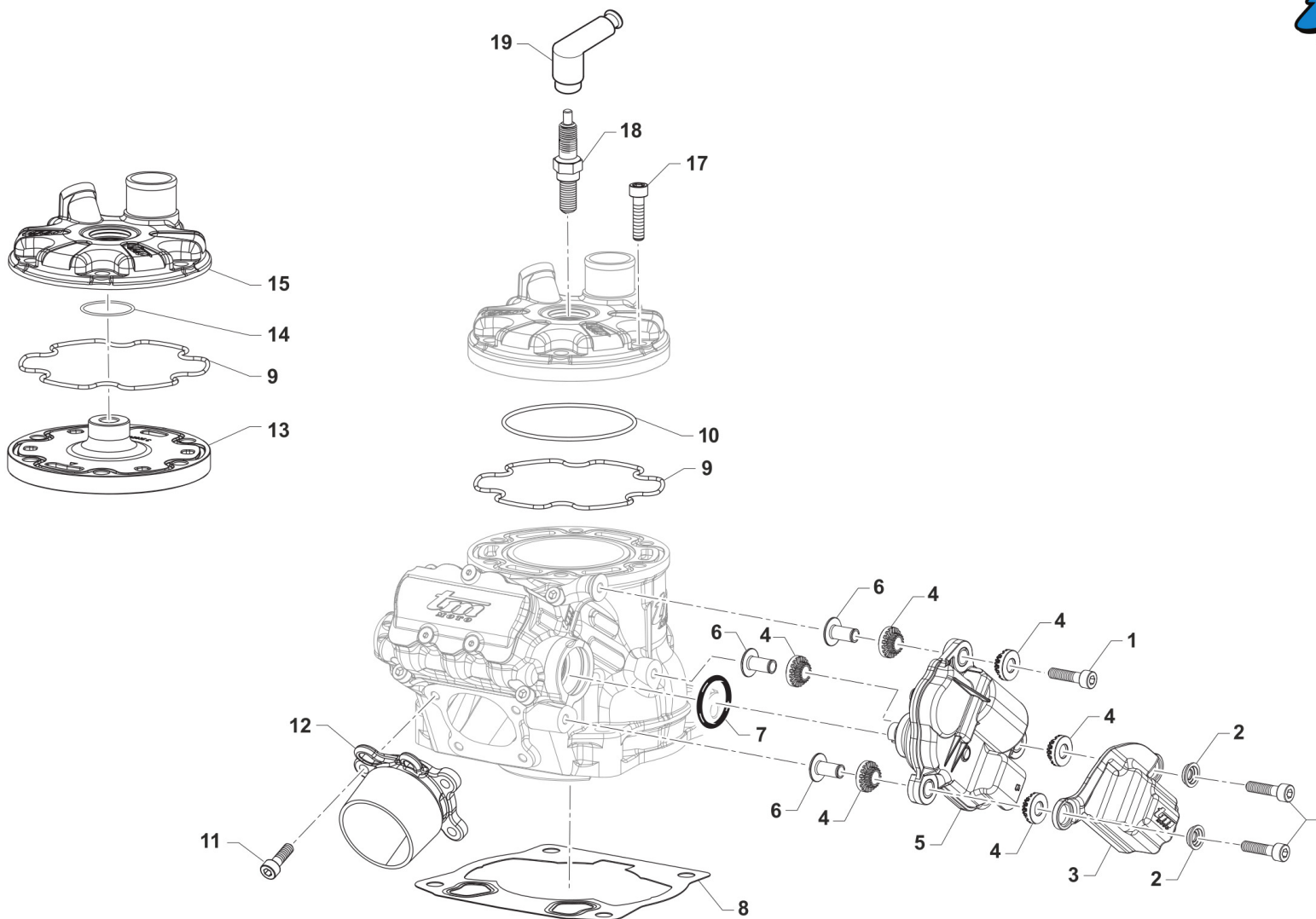

TM 0750.01



2T125MX25-M
2T 125 MX ES - ENGINE

CILINDRO 01 - 125 MX/EN CARB.
CYLINDER 01 - 125 MX/EN CARB

1

Pos.	Codice	Q.tà	Note	Descrizione	Description
1	49477	3		VITE TCEI 5X25 UNI 5931-912	BOLT TCEI 5X25
2	26238	2		BOCCOLA COVER ATTUATORE SBS 5X12X3	
3	67439	1		COVER ATTUATORE VALVOLA DI SCARICO SBS 11832 FD EVO MY2025	
4	21317	6		SILENT BLOCK 6.5X15X6.5 Z18	
5	68323	1		ATTUATORE VALVOLA DI SCARICO SBS 11832 FD EVO	
6	26241	3		BOCCOLA SOSP. ELAST. ATTUATORE VALV. SCARICO	
7	12047	1		O RING ORM 0220-30 22,0X3,0	
8	05538	1		GUARN. B/CIL 125 M.2024 0,30	
8	05539	1		GUARN. B/CIL 125 M.2024 0,40	
8	05540	1		GUARN. B/CIL 125 M.2024 0,50	
8	05541	1		GUARN. B/CIL 125 M.2024 0,60	
8	05542	1		GUARN. B/CIL 125 M.2024 0,20	
9	12043	2		O RING PREFORMATO CIL. 125 MY 2025	
10	12003.1	1		O RING INT.TESTA 125/144 FKM 75 SH MARRONE	O-RING, INT. HEAD 125 / 144cc VITON
11	49474	4		VITE TCEI 5X16 UNI 5931	BOLT TCEI 5X16
12	13127	1		COLLETTORE SCARICO A 4 VITI M5 D38	
13	02035	1		CAMERA COMBUSTIONE TESTA MX EN 125 2T	
14	12073	1		OR 20,00X2,00 ORM 0200-20 NBR 70	
15	02037	1		COPERCHIO TESTA 125 CARBURATORE MY 2025	
17	490048	6		VITE TCEI 7x30 8.8 5931-912	
18	F06105	1		CANDELA NGK CR9EIX CON/NIPPLO	SPARK PLUG NGK CR9EIX
19	21087	1		PIPETTA CANDELA SILICONE SCHERMATO 5K	



2T125MX25-M
2T 125 MX ES - ENGINE

CILINDRO 02 - 125 MX/EN CARB.
CYLINDER 02 - 125 MX/EN CARB

2

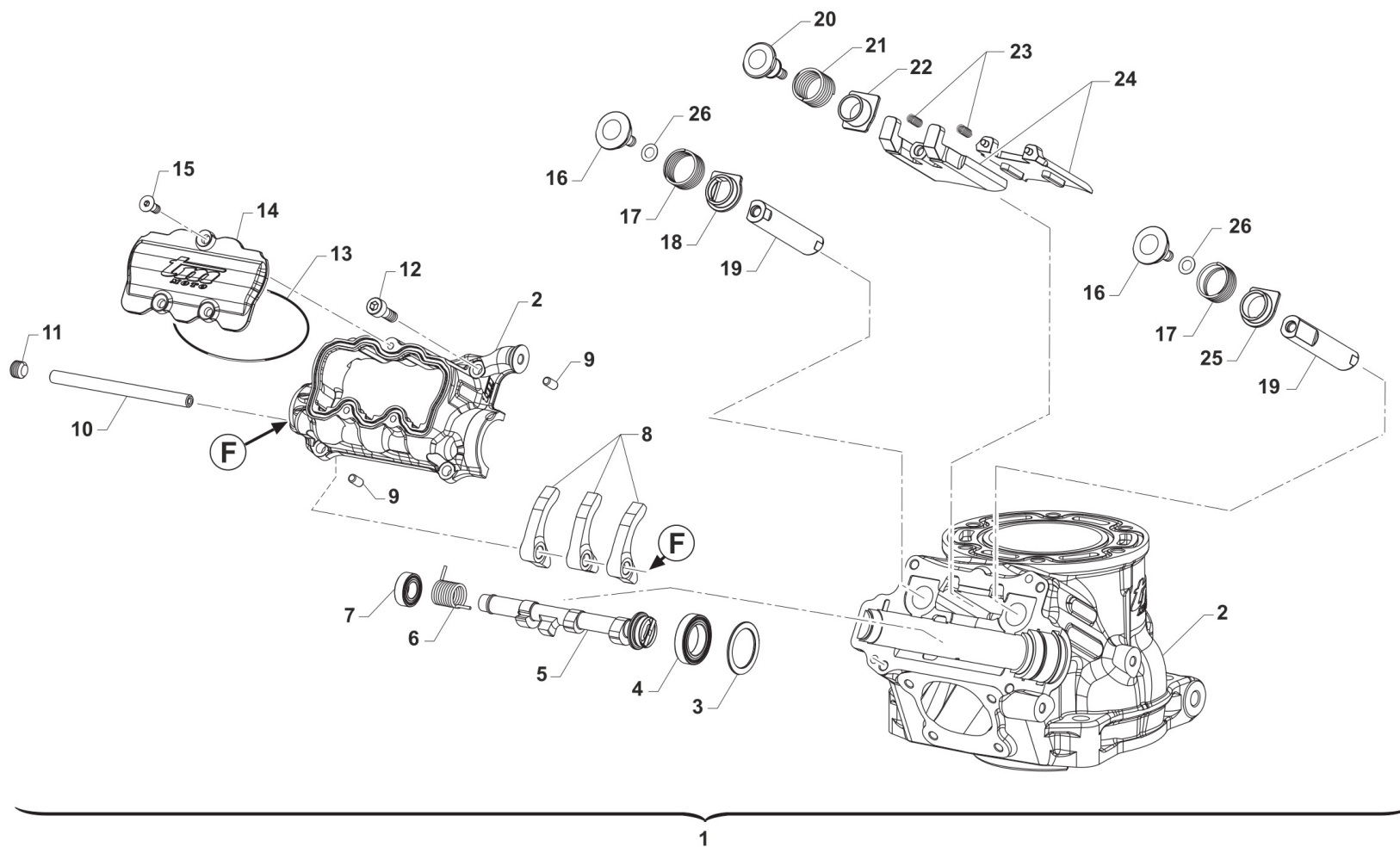

TM 0751



2T125MX25-M
2T 125 MX ES - ENGINE

CILINDRO 02 - 125 MX/EN CARB.
CYLINDER 02 - 125 MX/EN CARB

2

Pos.	Codice	Q.tà	Note	Descrizione	Description
1	01145	1		CILINDRO 125 MX/EN CARBURATORE MY 2025 CPL	
2	01142	1		CILINDRO 125 MX/EN CARBURATORE MY 2025 NUDO	
3	48061	1		ANELLO TIPO PS DIN 988 19x26x1	
4	F03388	1		CUSCINETTO 61802-2RS1	
5	28271	1		ALBERO A CAMME PER CINEMATISMO VALVOLA DI SCARICO 2T SBS	
6	16263	1		MOLLA A TORSIONE D.INT. 9.3x1.3 St.9.6 SX R=1.531 Nmm/°	
7	F03389	1		CUSCINETTO 8X16X5 628/8 2RS	BEARING
8	28268	3		BILANCIERE AZIONAMENTO VALVOLA SCARICO 2T	
9	F19504	2		RULLO D.4 X 8	PIN D.4 X 8
10	28074	1		SPINA CILINDRICA TEMPRATA DIN 7979 D - 6x80	
11	49717	1		GRANO 8 X 6	GRUB SCREW 6x8
12	49473	4		VITE TCEI 5X14	BOLT TCEI 5X14
13	12028	1		OR COP. POMPA H2O 2T 250/300 M.18->	O-RING WATER PUMP COVER 2S 250/300 MY.18->
14	001269	1		COPERCHIO ISPEZIONE CINEMATISMO DI SCARICO 125 2T	
16	28269	2		ALBERO A CAMME PER CINEMATISMO VALVOLA DI SCARICO 2T	
17	16261	3		MOLLA A COMPRESSIONE MOLATA 32.0x17.8x1.1 St.6.0 K=0.770 N/mm	
18	26283	1		PIATTELLO INFERIORE BOOSTER ANTIROTAZIONE SINISTRO	
19	22096	1		SET BOOSTER VALVOLA DX+SX 125 2025 (22091% +22092%)	
20	26268	1		PIATTELLO SUPERIORE VALVOLA PARZIALIZZATRICE SCARICO	
21	16262	1		MOLLA A COMPRESSIONE MOLATA 32.0x16.45x1.25 St.6.75 K=1.420 N/mm	
22	26266	1		PIATTELLO INFERIORE VALVOLA PARZIALIZZATRICE SCARICO	
23	16260	2		MOLLA A COMPRESSIONE 16.5x4.1x0.5 St.16 K=0.870N/mm	



2T125MX25-M
2T 125 MX ES - ENGINE

CILINDRO 02 - 125 MX/EN CARB.
CYLINDER 02 - 125 MX/EN CARB

2

Pos.	Codice	Q.tà	Note	Descrizione	Description
24	22095	1		VALVOLA GHIGL. 125 2025 (22089+22090)	
25	26284	1		PIATTELLINO INFERIORE BOOSTER ANTIROTAZIONE DESTRO	
26	F48407.010	1		RONDELLA 5x10x0,10 PS DIN 988	
26	F48407.020	1		RONDELLA 5x10x0,20 PS DIN 988	
26	F48407.030	1		RONDELLA 5x10x0,30 PS DIN 988	
26	F48407.050	1		RONDELLA 5x10x0,50 PS DIN 988	



2T125MX25-M
2T 125 MX ES - ENGINE

ALBERO MOTORE E PISTONE
CRANKSHAFT AND PISTON

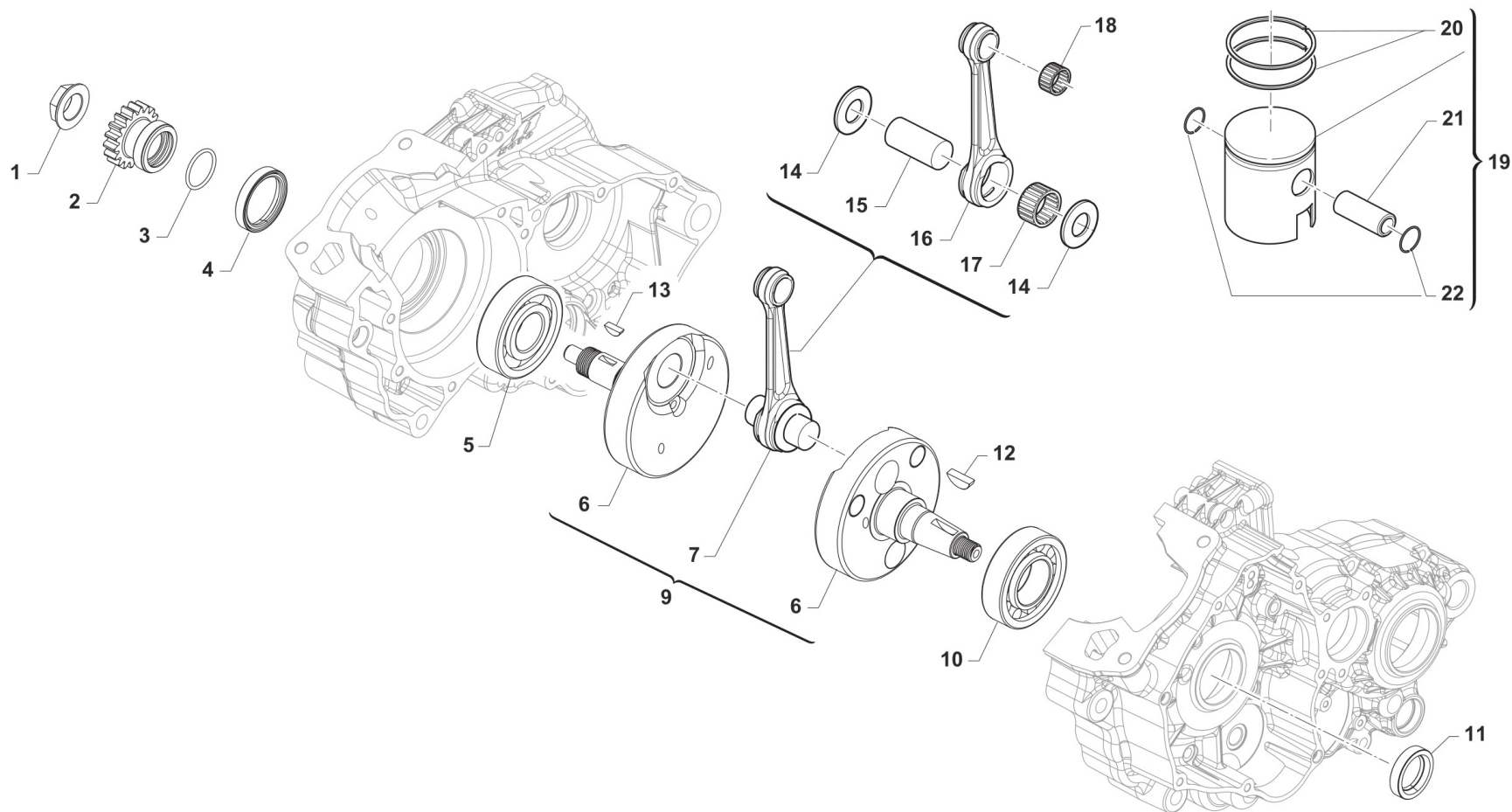

TM 0753



2T125MX25-M
2T 125 MX ES - ENGINE

ALBERO MOTORE E PISTONE
CRANKSHAFT AND PISTON

3

Pos.	Codice	Q.tà	Note	Descrizione	Description
1	F49816	1		DADO M18 x 1,25 SPECIALE 250N	
2	40322	1		PIGNONE COPPIA PRIMARIA Z18 MY2023	
3	12067	1		O RING 23X2	
4	04049	1		PARAOLIO FPJ 32x41x7	
5	03255	1		CUSCINETTO A SFERE ALB.MOTORE 125 M.13	BUSH, CRANKSHAFT 125 M.13
6	18291	1		COPPIA SEMIALBERI 125 Fi ES 2025	
7	18125.2	1		BIELLA 125Fi ASSE 22 x 50,4 CPL ASSE F.5	CONROD ASSY2 125 Fi PIN 22 x 50,4 mm Hole 5mm
9	18297	1		ALBERO MOTORE CPL 125 Fi ES 2025	
10	03026.1	1		CUSCINETTO ALBERO MOTORE NJ206	BUSH, NJ206 CRANKSHAFT
11	04039	1		PARAOLIO 22x33x7 PTFE	
12	49012	1		CHIAVETTA PIGNONE COPPIA 250	WOODRUFF KEY, 250/300 19x7,5x5
13	490035	1		LINGUETTA A DISCO UNI 6606 4x5	
14	18239.1	2		RONDELLA ARGENTATA D.22 X 1 v2 TONDA/MODIF.	
15	18091.4	1		ASSE ACCOP. 22 X 50.4 F.5	CRANKPIN 22 X 50,4 hole 5mm
16	18053.2	1		BIELLA ASSE 22 FORG. NUDA 109,8	CONROD D.22mm FORGED 109,8
17	17016	1		GABBIA ARGENTATA 222815 R.SF.	
18	19034	1		GABBIA SPINOTTO 15X19X17,3	TOP END B. 15X19X17,3
19	10029.94	1		PISTONE 53.94 125 ES 2025 2F CPL	
19	10029.95	1		PISTONE 53.95 125 ES 2025 2F CPL	
19	10029.96	1		PISTONE 53.96 125 ES 2025 2F CPL	
19	10029.97	1		PISTONE 53.97 125 ES 2025 2F CPL	
19	10029.98	1		PISTONE 53.98 125 ES 2025 2F CPL	
20	11078	2		SEGMENTO D. 54 X 0,8 RIKEN/NISMO	PISTON RING D.54 X 0,8 Riken
21	09000	1		SPINOTTO PISTONE VERTEX 125	PISTON PIN VERTEX 125

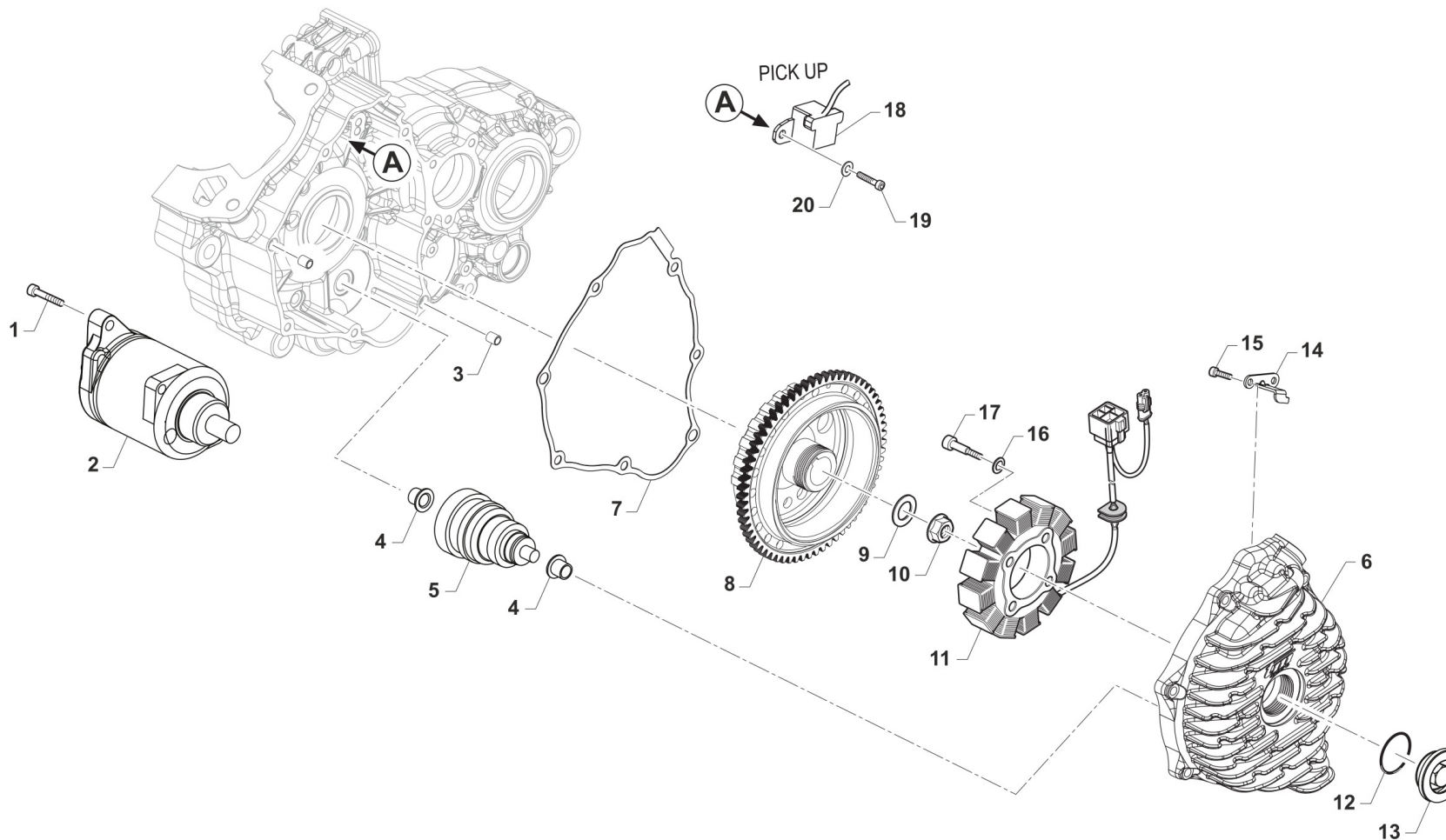

TM 0754



2T125MX25-M
2T 125 MX ES - ENGINE

ACCENSIONE CARBURATORE

4

Pos.	Codice	Q.tà	Note	Descrizione	Description
1	49485	2		VITE TCEI 6X25 UNI 5931	BOLT TCEI 6x25
2	68206	1		MOTORINO AVVIAMENTO 250/300 M18->	STARTER MOTOR 250/300 T.S. MY19->
3	26041	2		GRANO CENTRAGGIO D.7X8 F.5,2	DOWEL PIN 7 x 8 Hole 5,2
4	26256	2		BOCCOLA FLANGIATA BENDIX AVV. EL. 250/300 2T I.E.	FLANGE BUSH BENDIX EL.ST. 250/300 T.S. Fi
5	68207	1		BENDIX MOTORE 250/300 2T ES MY 2019	BENDIX
6	30394.1	1		COPERCHIO ACCENSIONE 2T 125 ES MY 2025 - 3 FORI	
7	05286	1		GUARNIZIONE COPERCHIO ACCENSIONE	
8	15258	1		ROTORE CPL IN PLASTONEODIMIO (da 15253.1)	
9	49613	1		RONDELLA ACCIAIO 12	STEEL WASHER 12
10	49056	1		DADO ACCENSIONE MX/E 12 x 1.25	NUT, IGNITION 100cc
11	F15547	1		STATORE KOKUSAN YS 9018 C. KOK / SUM	
12	F12322	1		O RING 2106	O-RING
13	49290	1		TAPPO COPERCHIO ACC. 250/300 2T MY 2019(PUO' SOSTITUIRE F49833)	CAP IGNITION COVER 250/300 2S MY19
14	F30945	1		PROTEZIONE CAVI ACC.NE 250N	PROTECTION IGNITION WIRES 250N
15	490047	2		VITE TCEI 7x35 8.8 5931-912 BRU	
16	49866	4		RONDELLA 4 x 12 x 1	
17	49384	4		VITE TCEI 4X35	
18	F15478	1		PICK-UP KOKUSAN	PICK-UP KOK PU5157
19	49472	2		VITE TCEI 5X12 UNI 5931-912 Brun	BOLT TCEI 5X12
20	49601	2		RONDELLA 5X11	WASHER 5x11



2T125MX25-M
2T 125 MX ES - ENGINE

FRIZIONE
CLUTCH

5

Pos.	Codice	Q.tà	Note	Descrizione	Description
1	30375	1		ATTUATORE FRIZ. Ø26 125 MY 25 CPL	
2	12091	1		O RING CORPO CARTUCCIA FR.COMP	O-RING
3	F19517	1		SFERA X PIST.FRIZ.IDRAUL.250N	BALL IDR. CLUTCH PISTON 250N
4	12259	1		O RING PISTONE FR.125/250 VITON (Verde)	O-RING, CLUTCH PISTON 125/250
5	F35554	1		PISTONCINO POMPA FRIZIONE	PISTON CLUTCH MASTER CYLINDER
6	F16470	1		MOLLA CONTR. PIST/FRI 450Fi'15	
7	35264	1		VITE SPURGO OLIO FRIZ.IDR.6X1	SCREW AIR BLEED HYDRAUL.CLUTCH
8	30371	1		CORPO ATTUATORE FRIZ. Ø26 125 MY 25	
9	49477	1		VITE TCEI 5X25 UNI 5931-912	BOLT TCEI 5X25
10	40083	1		PROTEZIONE PIGNONE ERGAL 250/300 2T MX/SMX MY 25	
11	40075	1		PROTEZIONE PIGNONE 250/300 IE	PROTECTION, PLASTIC
12	26211	2		BOCCOLA PROT. PIGNONE 250 F.5	COLLAR, SPROCKET 250cc H.5
13	49535	2		VITE TCEI 5X35 UNI 5931-912	BOLT TCEI 5X35
15	35067	1		ASTINA FRIZIONE IDRAULICA 125Fi MY24	
16	26197	1		BOCCOLA INGR.TRASM.PRIM. 125 2022	
17	19111	1		GABBIA A RULLI K26x30x17	
18	40323	1		COPPIA PRIM. 125 Z63 MY2023	
19	48048	1		SPESSORE INGR.TRASM. PRIM.125 2022 (20X34.8X2.5)	
20	25101	1		TAMBURELLO FRIZIONE	
21	F48353	1		SPESSORE PS 18X25X1	SPACER
22	49060	1		DADO TAMBUR.FRIZ. ALB.PRIM. 250/300 M18X1.5	NUT, CLUTCH CENTER 250cc
23	35056	8		DISCO FRIZ. GUARN. 125/144Fi 2T MY2025	
24	35055	7		DISCO FRIZ. ACC. 125/144Fi 2T SP.1,2 MY24	
25	F35582	1		FUNGO FRIZIONE IDRAULICA 2015	PIECE, CLUTCH LIFTER
26	19022	1		GABBIA A RULLI RAD. AXK 1528	BUSH CAGE AXK 1528, RADIAL
27	19023	1		RONDELLA GABBIA RULLI AS 1528	WASHER, NEEDLE CAGE AS 1528
28	09006	1		ANELLINO FERMA SPINOTTO 80/85/100	CLIP, PISTON PIN 80/85/100cc
29	25102	1		SPINGIDISCO FRIZIONE	



2T125MX25-M
2T 125 MX ES - ENGINE

FRIZIONE
CLUTCH

5

Pos.	Codice	Q.tà	Note	Descrizione	Description
30	16077	1		MOLLA FRIZIONE 125/144 Fi MY2023	
31	25103	1		ELEMENTO FISSAGGIO MOLLA FRIZIONE	
32	49473	1		VITE TCEI 5X14	BOLT TCEI 5X14



2T125MX25-M
2T 125 MX ES - ENGINE

CARTER FRIZIONE
CLUTCH CASE

6

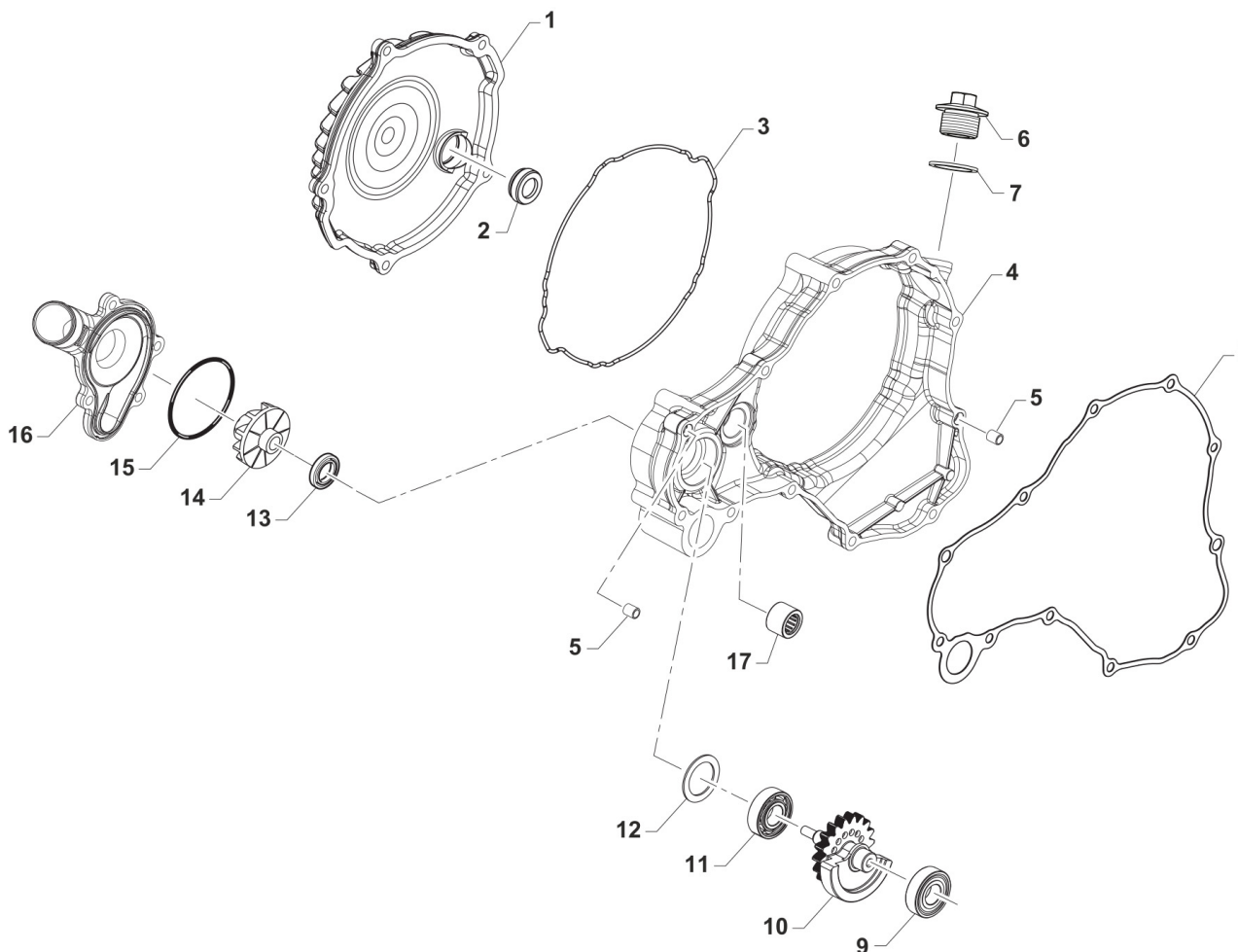

TM 0756



2T125MX25-M
2T 125 MX ES - ENGINE

CARTER FRIZIONE
CLUTCH CASE

Pos.	Codice	Q.tà	Note	Descrizione	Description
1	30370	1		COPERCHIO FRIZIONE 125 MY 2025	
2	04019	1		OBLO' OLIO 125 - LIVELLO OIL Fi 2T	OIL WINDOW 125 K MF1 MF2
3	12270	1		O RING SAGOMATO COP. FRIZIONE 125 FI 2T 2025	
4	30369	1		CARTER FRIZIONE 125 2T MY 2025	
5	26041	2		GRANO CENTRAGGIO D.7X8 F.5,2	DOWEL PIN 7 x 8 Hole 5,2
6	F49844	1		TAPPO CARICO OLIO 250N	
7	F49920	1		RONDELLA ALL 20.4X26X1.5	WASHER 20,4X26X1,5 ALUM.
8	05287	1		GUARNIZIONE CARTER FRIZIONE 125 ES	
9	03094	1		CUSCINETTO A SFERE 12x28x8 6001-2RSH/C3	
10	40324	1		INGRANAGGIO POMPA ACQUA E CONTRALBERO 125 ES MY2025	
11	03093	1		CUSCINETTO A SFERE 12x28x8 6001 C4	
12	48062	1		RONDELLA 20x28x1 PS DIN 988	
13	F04363	1		PARAOLIO 8X22X5 250/09->	OIL SEAL 8x22x5 (250F/09)
14	F28679	1		GIRANTE POMPA ACQUA 250N	IMPELLER, H2O PUMP 250Fi
15	12046	1		X-RING QUADRING 2250 = 2.37 (63.22x1.78)	
16	30393	1		COPERCHIO POMPA ACQUA 125 MY 2025	
17	03092	1		CUSCINETTO A RULLINI 10x17x12	



2T125MX25-M
2T 125 MX ES - ENGINE

BASAMENTO E PACCO
CASE AND REEDS BOX

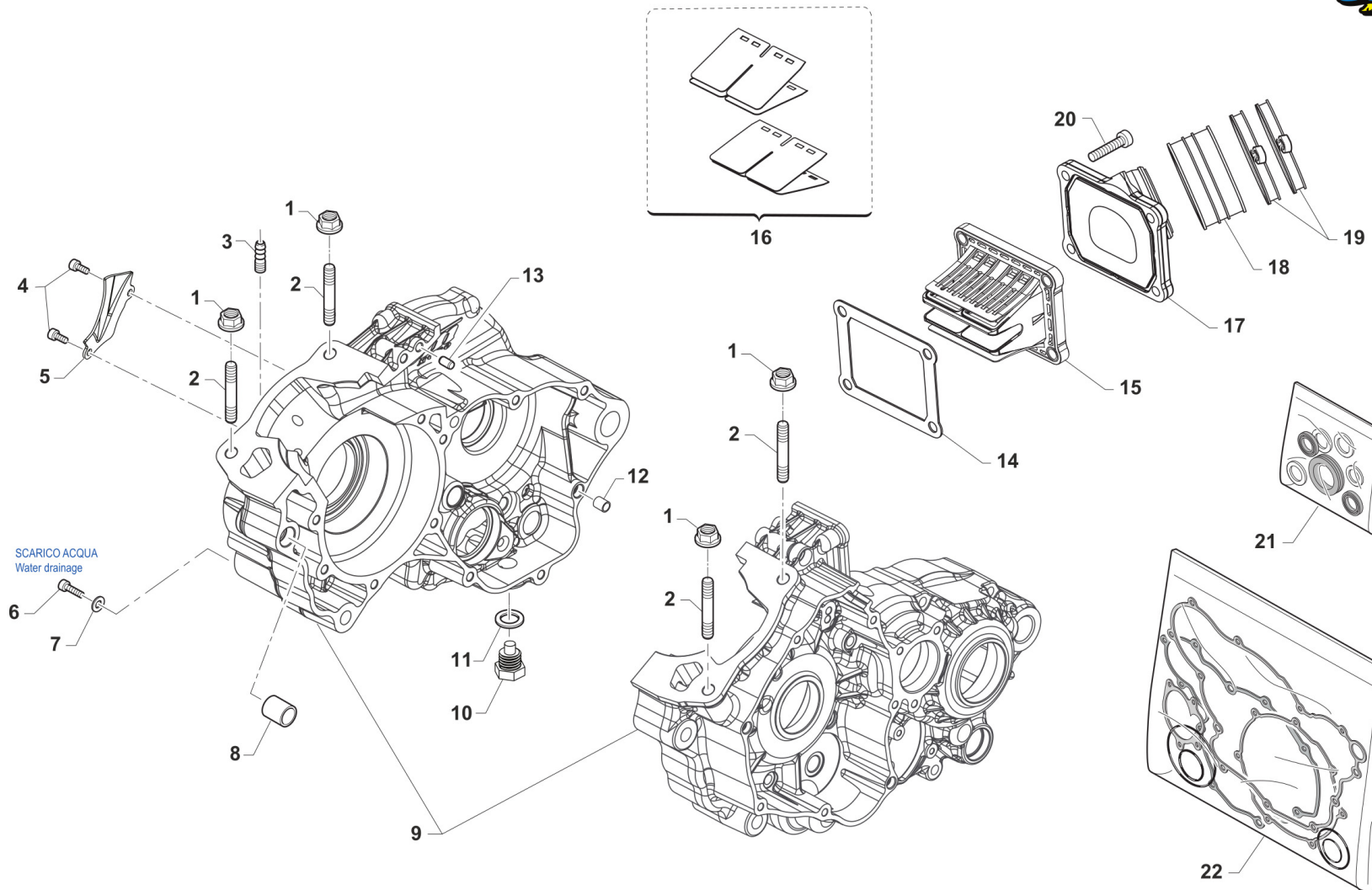

TM 0757



2T125MX25-M
2T 125 MX ES - ENGINE

BASAMENTO E PACCO
CASE AND REEDS BOX

7

Pos.	Codice	Q.tà	Note	Descrizione	Description
1	49191	4		DADO M 8 X 1,25 CH. 10 FLANGIATO	
2	49028	4		PRIGIONIERO CILINDRO M 8 X 52 125 2025	
3	49004	1		RACCORDO SFIATO CARTER	PIPE, CRANKCASE BREATHER
4	49580	2		VITE TCEI 4X10 5931-912 Brun	BOLT
5	26162	1		PIASTRINO CONV.OLIO 250/300 18	PLATE
6	49480	1		VITE TCEI 6X10 UNI 5931	BOLT TCEI 6X10
7	49104	1		RONDELLA 6 x 10 x 1,5 ALLUMINIO	WASHER 6 x 10 x 1.5 ALUMINUM
8	F26428	1		GRANO RIFERIMENTO 12X13 F10.2	GRUB SCREW 12X13 H.10,2mm
9	30367	1		BASAMENTO MOTORE 2T 125 ES MY 2025	
10	49301	1		TAPPO OLIO C/CALAM. 2T	OIL PLUG WITH MAGNET
11	49103	1		RONDELLA 14X20X1,5 ALLUMINIO	WASHER, 14 X 20 X 1.5 ALUMINUM
12	F26304	1		GRANO RIFERIMENTO 6.1X8X9.5 4T	GRUB SCREW 6.5X8XX9.5 4S
13	19006	1		RULLINO 5 X 8	PIN 5 X 8, CLUTCH ROD
14	05631	1		GUARN. PACCO LAMELLE VFORCE 3 E VFORCE 4X	
15	20259	1		PACCO LAMELLARE VFORCE 4R TM	
16	20098	1		LAMELLE V-FORCE 4X 125 2025	
17	13129	1		COLLETTORE ASPIRAZIONE 125 2T CARBURATORE	
18	13009	1		MANICOTTO COLLETTORE ASP.97/14	MANIFOLD RUBBER,INTAKE M.97/14
19	51054	2		FASCETTA SM9 D.52	CLAMP SM9 D.52mm
20	49538	4		VITE TCEI 6X22 UNI 5931	
21	04046	1		KIT PARAOLI 125 ES MY 2025	
22	05632	1		KIT GUARN. + OR 125 ES MY 2025	



2T125MX25-M
2T 125 MX ES - ENGINE

COMANDO CAMBIO
GEARSHIFT MECHANISM

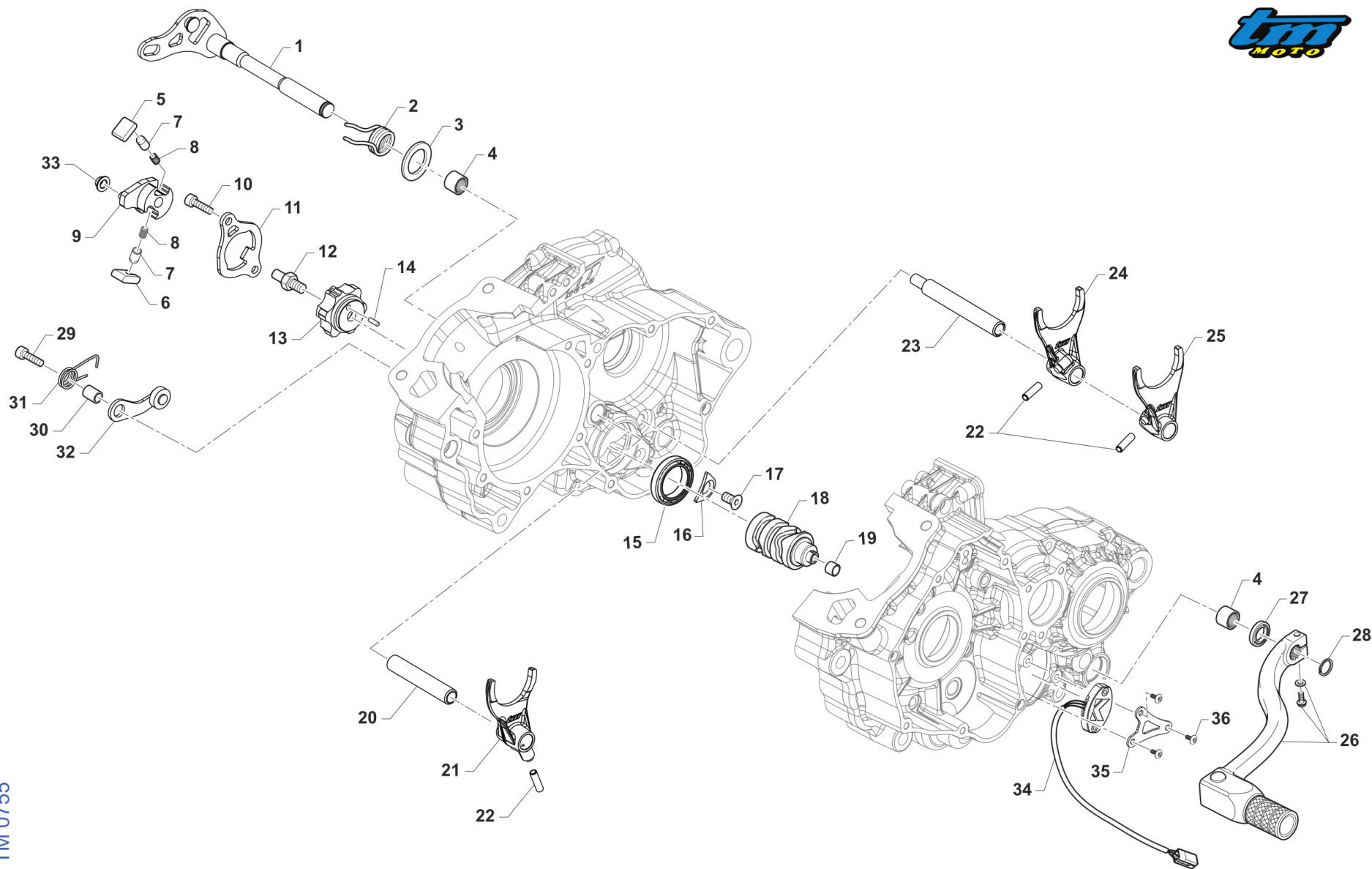

TM 0755



2T125MX25-M
2T 125 MX ES - ENGINE

COMANDO CAMBIO
GEARSHIFT MECHANISM

Pos.	Codice	Q.tà	Note	Descrizione	Description
1	28105	1		ALBERO COMANDO CAMBIO 250/300 IE CPL	SHAFT, GEARSHIFT 250/300 IE CPL
2	16065	1		MOLLA RITORNO LEVA CAMBIO 250 2T IE	SPRING, RETURN GEAR LEVER 250 2S EI
3	49073	1		RONDELLA 12,1X22X1	WASHER 12,1X22X1 125 MF1/2
4	19060	2		ASTUCCIO A RULLI HK 1212	NEEDLE CAGE HK 1212
5	F26587	1		CRICCHETTO SX 2T 250/300 ES	RATCHET, LF GEAR (HT) 250 M3
6	F26588	1		CRICCHETTO DX 2T 250/300 ES	RATCHET, RH GEAR (HT) 250 M3
7	F26592	2		PUNTALE CRICCHETTO 2T 250/300 ES	PIN, RATCHET GEAR (HT)
8	F16469	2		MOLLA PER PUNTALE 2T 250/300 ES	SPRING, GEARBOX PIN EDM
9	F26620	1		PORTACRICCHETTI HT 2T 250/300 ES	GEAR
10	49481	2		VITE TCEI 6X12	BOLT TCEI 6X12
11	26160	1		PIASTRINO RIENTRO CRIC.250 M18	PLATE
12	F49873	1		PERNO FILETTATO PORTACRICCHETTI (HT) 2T 250/300 ES	THREADED PIN FOR RATCHET HOLDER (HT)
13	26181	1		TESTA ALBERO DESMO ROT.D12 125/144 2T M22	
14	F19504	1		RULLO D.4 X 8	PIN D.4 X 8
15	F03381	1		CUSCINETTO 61805	BUSH 61805
16	F48352	1		PIASTRINO FISSA CUSCINETTO D72	PLATE
17	49403	1		VITE TSEI 6X12 ZINCATO	SCREW TSEI 6x12
18	33262	1		ALBERO DESMO 2T 125 ES 6M CPL MY 2025	
19	26260	1		BOCCOLA ALB. DESMODROMICO 250/300 2T I.E.	BUSH
20	33260	1		PERNO FORCHETTA AP 250/300 MY19	PIN, MAINSHAFT FORK
21	33028	1		FORCHETTA ALB.PRIM. 125/144 2T 5^/6^ (2022)	
22	F19533	3		RULLO D.6 X 15	PIN
23	33025	1		PERNO FORCHETTA AS 250/300 MY19	PIN, COUNTERSHAFT FORKS
24	33023	1		FORCHETTA A.S.1^3^ 250/300 M18 1A E 3A	FORK 1, COUNTERSHAFT
25	33027	1		FORCHETTA ALB.SEC. 250/300 2T 6M 2^/3^ (2020)	
26	43049	1		LEVA CAMBIO 2T (485) MY19->	GEAR LEVER 250 / 300 T.STR. EL.ST. M.19->
27	04038	1		PARAOLIO LEVA CAMBIO 250/300 2T I 12x20x5 l.parapolv.	OIL SEAL GEAR LEVEL 250/300 2S Fi 12x20x5
28	49212	1		SEEGER E12 LEVA CAMBIO	CIRCLIP D.12 - EXTERNAL



2T125MX25-M
2T 125 MX ES - ENGINE

COMANDO CAMBIO
GEARSHIFT MECHANISM

8

Pos.	Codice	Q.tà	Note	Descrizione	Description
29	49485	1		VITE TCEI 6X25 UNI 5931	BOLT TCEI 6x25
30	26007	1		DISTANZIALE MOLLA BLOCCAMARCE	SPACER, STOP GEAR SPRING
31	F16447	1		MOLLA BLOCCA MARCE 250N SOSTITUITA DA F16447.3	SPRING, STOP GEAR 250 4S
32	26095	1		PIASTRINO BLOCCAMARCE KV/95CPL + MOTO	PLATE, STOP GEAR KV/95 ASSY
33	F26593	1		BOCCOLA FLANGIATA PORTACRICCHETTO F26620	LEVER BUSH
34	F08459	1		SENSORE POSIZIONE CAMBIO eM060 CPL G.ANTIORARIO	
35	26280	1		PIASTRINO FISSAGGIO SENSORE POSIZIONE CAMBIO 125 2T	
36	490047	3		VITE TCEI 7x35 8.8 5931-912 BRU	



2T125MX25-M
2T 125 MX ES - ENGINE

CAMBIO MX
GEARBOX MX

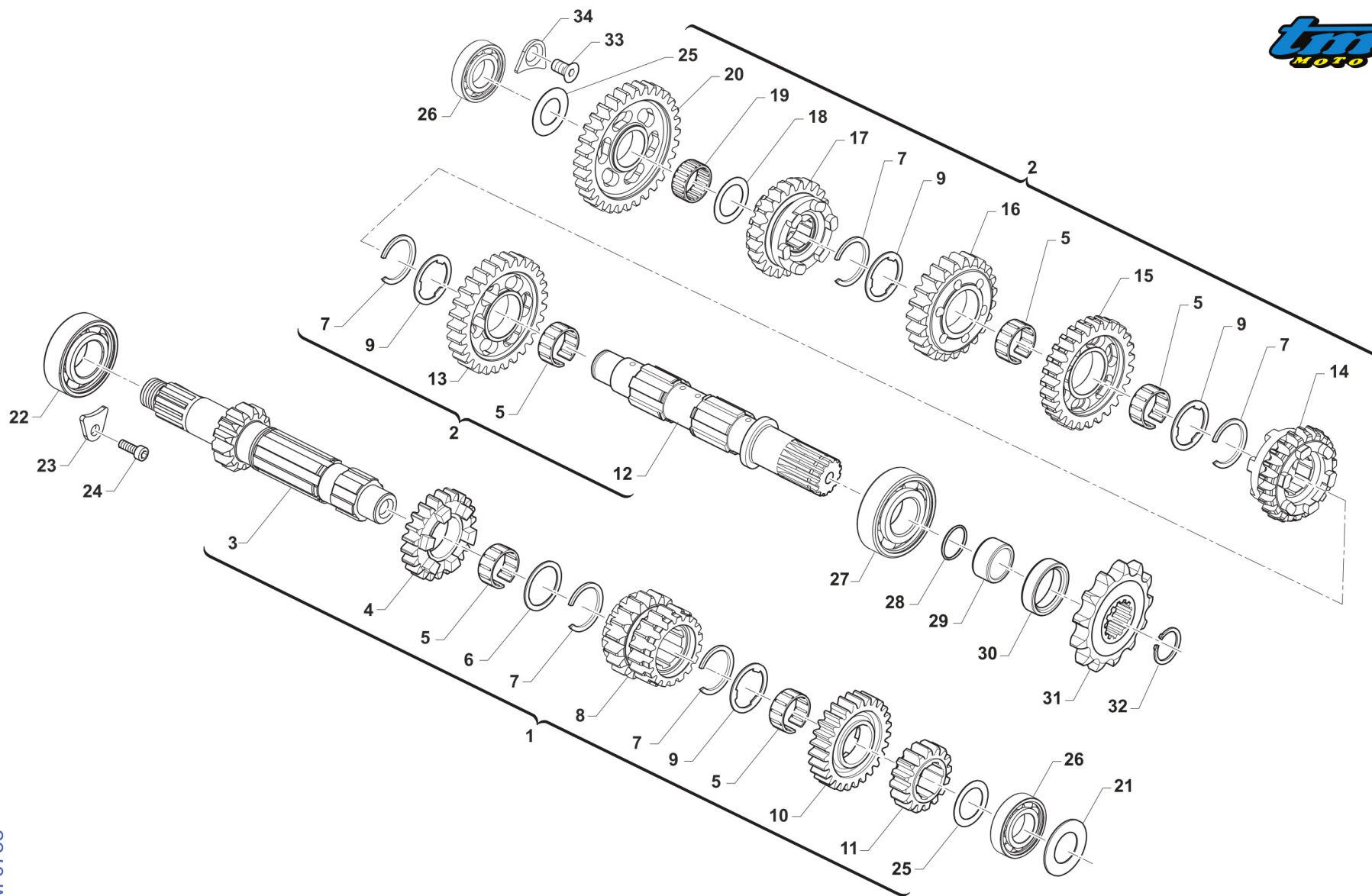

TM 0758



2T125MX25-M
2T 125 MX ES - ENGINE

CAMBIO MX
GEARBOX MX

Pos.	Codice	Q.tà	Note	Descrizione	Description
1	40086	1		ALBERO PRIM. CPL 125 ES 2025 MX	
2	40087	1		ALBERO SECOND. CPL 125 ES 2025 MX	
3	40720	1		ALBERO PRIMARIO Z 15 125FI 2T MX 2020	
4	40724	1		INGR A.P. 5a Z 21 125FI 2T MX/EN 2020	
5	F19524	5		GABBIA A RULLI 22X26X10 TAGL.	NEEDLE BEARING 22 X 26 X 10
6	48259	1		SPESSORE D.25.1 x 31 x 1.5 CAMBIO INT.55 6M	
7	F49869	5		SEEGER SW 24 (EST.) "SEEGER"	CIRCLIP SW 24 (EXTERNAL)
8	40723	1		INGR A.P. 3/4a Z 18/18 125FI 2T MX/EN 2020	
9	48258	4		SPESSORE DENT.CAMBIO INT.55 6M	SPACER GEAR INT.55 6S
10	40725	1		INGR A.P. 6a Z 22 125FI 2T MX 2020	
11	40722	1		INGR A.P. 2a Z 16 125FI 2T MX/EN 2020	
12	40727	1		ALBERO SECONDARIO 125FI 2T MX/EN 2020	
13	40730	1		INGR A.S. 2a Z 29 125FI 2T MX/EN 2020	
14	40734	1		INGR A.S. 6a Z 22 125FI 2T MX 2020	
15	40731	1		INGR A.S. 3a Z 27 125FI 2T MX/EN 2020	
16	40732	1		INGR A.S. 4a Z 23 125FI 2T MX/EN 2020	
17	40733	1		INGR A.S. 5a Z 23 125FI 2T MX/EN 2020	
18	F48353	1		SPESSORE PS 18X25X1	SPACER
19	F19514	1		GABBIA A RULLI 18X22X10	NEEDLE CAGE 18X22X10
20	40728	1		INGR A.S. 1a Z 31 125FI 2T MX 2020	
21	48063	1		RASAMENTO Ø17,3 x Ø32,9 x 0,30	
22	03164.1	1		CUSCINETTO SFERE (20x42x12) 6004 C3	
23	26156	1		PIASTRINO BLOC.CUSC.C.A.125 OK /250/300	PLATE, BEARING HOLDER 125 OK
24	49962	1		VITE TCEI 6X12 BASSA / F.GUIDA	BOLT
25	48253	2		SPESSORE CAMBIO 17X30X1 250	SPACER, GEAR BOX 250cc 17X30X1
26	03165	2		CUSCINETTO SFERE (17x35x8) 16003 C3	
27	F03368	1		CUSCINETTO 62/22 C3 22x50x14	BUSH, 62/22 C3 22x50x14
28	F12320	1		O RING BOCCOLA PIGNONE 250/09	O-RING NBR 2087



2T125MX25-M
2T 125 MX ES - ENGINE

CAMBIO MX
GEARBOX MX

Pos.	Codice	Q.tà	Note	Descrizione	Description
29	F26421	1		DISTANZ. PIGNONE CATENA 250N	SPACER SPROCKET CHAIN 250N
30	04113	1		PARAOLIO 28 X 38 X 7	OIL SEAL 28 x 38 x 7
31	F40889	1		PIGNONE CATENA 250N - Z13	SPROCKET 13T, DRIVE 250Fi
31	F40933	1		PIGNONE CATENA 250N - Z14	SPROCKET 14T, DRIVE 250Fi
31	F40956	1		PIGNONE CATENA 250N - Z12	SPROCKET 12T, DRIVE 250Fi
32	49217	1		SEEGER E22 ANELLO ALB/S	CIRCLIP D.22 - COUNTERSHAFT
33	49403	1		VITE TSEI 6X12 ZINCATO	SCREW TSEI 6x12
34	F48352	1		PIASTRINO FISSA CUSCINETTO D72	PLATE



2T125MX25-M
2T 125 MX ES - ENGINE

VITI MOTORE
BOLTS

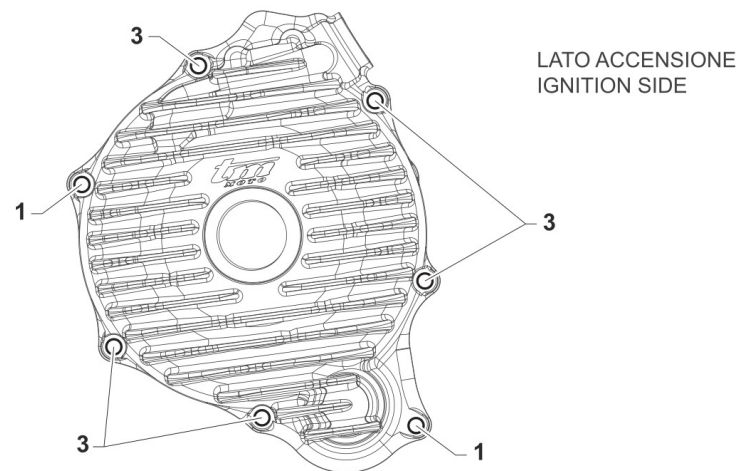
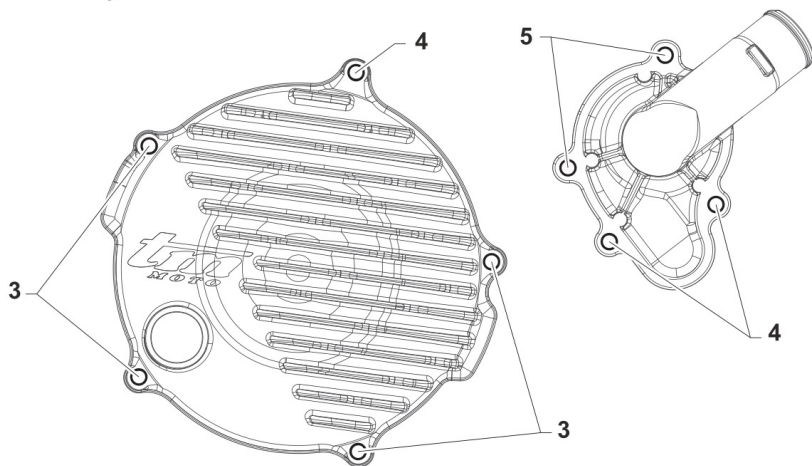
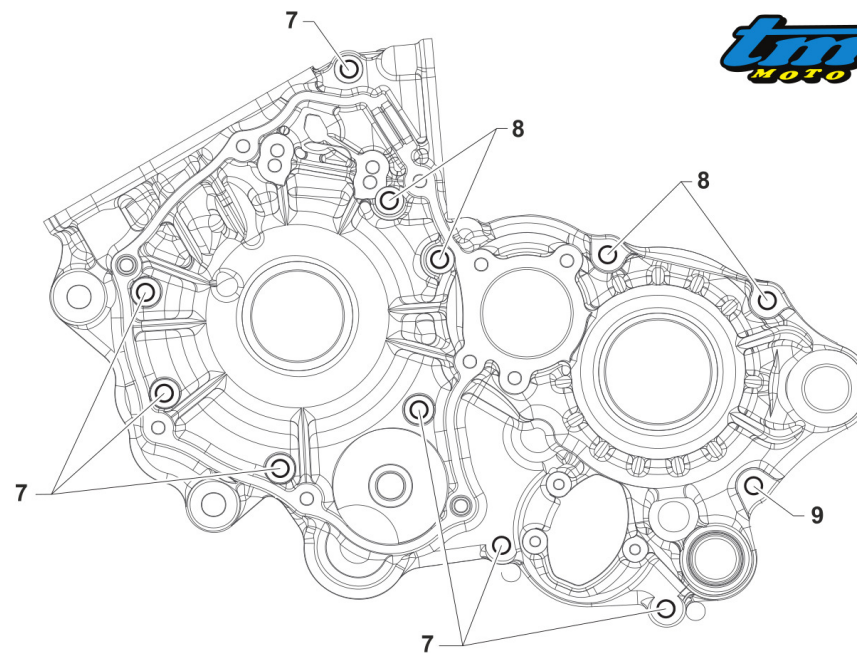
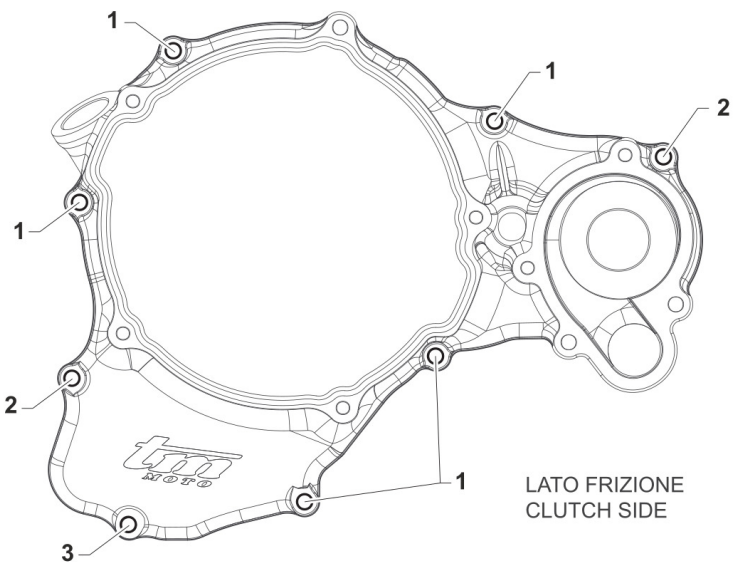

TM 0759



2T125MX25-M
2T 125 MX ES - ENGINE

VITI MOTORE
BOLTS

10

Pos.	Codice	Q.tà	Note	Descrizione	Description
1	49477	7		VITE TCEI 5X25 UNI 5931-912	BOLT TCEI 5X25
2	49478	2		VITE TCEI 5X30 UNI 5931	BOLT TCEI 5X30
3	49476	10		VITE TCEI 5X20 UNI 5931	BOLT TCEI 5X20
4	49578	3		VITE TCEI 5X55	BOLT TCEI 5X55
5	49474	2		VITE TCEI 5X16 UNI 5931	BOLT TCEI 5X16
7	49489	7		VITE TCEI 6X45 UNI 5931	BOLT TCEI 6x45
8	49491	4		VITE TCEI 6X55	BOLT TCEI 6X55
9	49492	1		VITE TCEI 6X60	BOLT TCEI 6X60