



USES AND
RACOMMENDS



www.tmracing.it

TM Racing SpA - Via Fano, 6
61122 Pesaro - ITALY
Phone: +39 0721 25113

2T300FISMR25-M

2T 300 FI SMR

2S 300 FI SMR

29/10/2024



INFORMAZIONI GENERALI

Il presente catalogo serve per richiedere con esattezza le parti di ricambio.

Nelle ordinazioni indicare:

1) Il numero di matricola del Telaio che è stampigliato sul lato destro del canotto di sterzo. Nei modelli EN, SMR, SMR il numero di matricola è riportato anche su una targhetta posta sul lato sinistro (Vedi foto).

2) il numero di serie del Motore. E' posto sulla sinistra del motore tra la leva cambio e i coperchio accensione (Vedi foto).

3) Il codice dei particolari seguito dalla descrizione.

4) Il colore per i pezzi verniciati o comunque colorati.

Le indicazioni destra e sinistra si riferiscono ai lati del veicolo rispetto al senso di marcia.

Foto e disegni sono solo a scopo informativo e potrebbero non corrispondere esattamente alle caratteristiche dei prodotti.

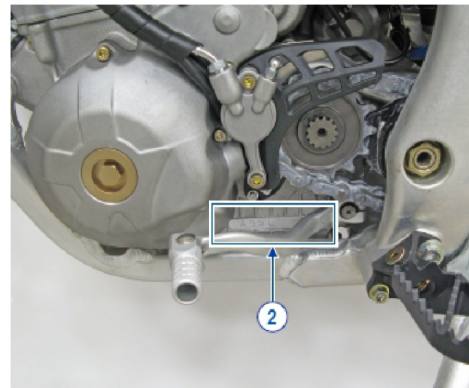
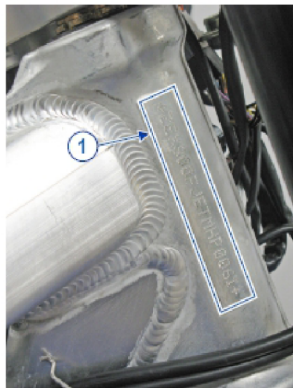

GENERAL INFORMATION

The present spare parts catalogue enables one to order exactly the right spare part.

When ordering specify:

1) The frame serial number. It is embossed on the right side of the steering metal tube. In the EN, SMR and SMR models, the serial number is also stated on a plate positioned on the left hand side (See photo).

2) The engine serial numer. It is located on the left side of the engine between the gear lever and the ignition cover (See photo).

3) The part's code number followed but its description.

4) Indicate colour for painted or colored parts.

References to right and left apply to the vehicle in terms of its direction of movement.

Photos and drawings are for informational purposes only and may not exactly match the characteristics of the products.

NOTE – LEGENDA

MY

NOVITA' INTRODOTTA DIFFERENTE O NON PRESENTE NEL MODELLO DELL'ANNO PRECEDENTE

PART DIFFERENT OR NOT PRESENT IN THE REVIOUS YEAR MODEL

5M

MOTORE CON CAMBIO A 5 MARCE
ENGINE WITH 5 GEARS SPEED

6M

MOTORE CON CAMBIO A 6 MARCE
ENGINE WITH 6 GEARS SPEED

KS

MOTORE CON SOLO KICK STARTER
ENGINE WITH KICK STARTER ONLY

ES

MOTORE CON AVVIAMENTO ELETTRICO
ENGINE WITH ELECTRIC STARTER

X

RICAMBIO NON DISPONIBILE ALLA VENDITA
PART CAN NOT BE SOLD SEPARATELY

Le illustrazioni riportate in questo manuale sono fornite solo come riferimento e possono variare dal prodotto effettivo,

Dati indicativi soggetti a modifiche senza impegno di preavviso.

The illustrations in this manual are for reference only and may vary from the actual product.

All data are subject to modification without prior notice.



2T300FISMR25-M
2T 300 FI SMR - 2S 300 FI SMR

SOMMARIO
TABLE OF CONTENTS

CILINDRO - CYLINDER.....	4
MOTORINO VALVOLA - ELECTRIC VALVE SYSTEM.....	7
ALBERO MOTORE E PISTONE - CRANKSHAFT AND PISTON.....	9
LATO CARTER FRIZIONE - CLUTCH CASE SIDE.....	11
FRIZIONE 6M - CLUTCH 6 SPEED.....	14
BASAMENTO E CONTRALBERO.....	17
FORCHETTE CAMBIO 6M.....	20
CAMBIO 6M - GEAR BOX.....	23
ACCENSIONE - IGNITION.....	26



2T300FISMR25-M
 2T 300 FI SMR - 2S 300 FI SMR

CILINDRO CYLINDER

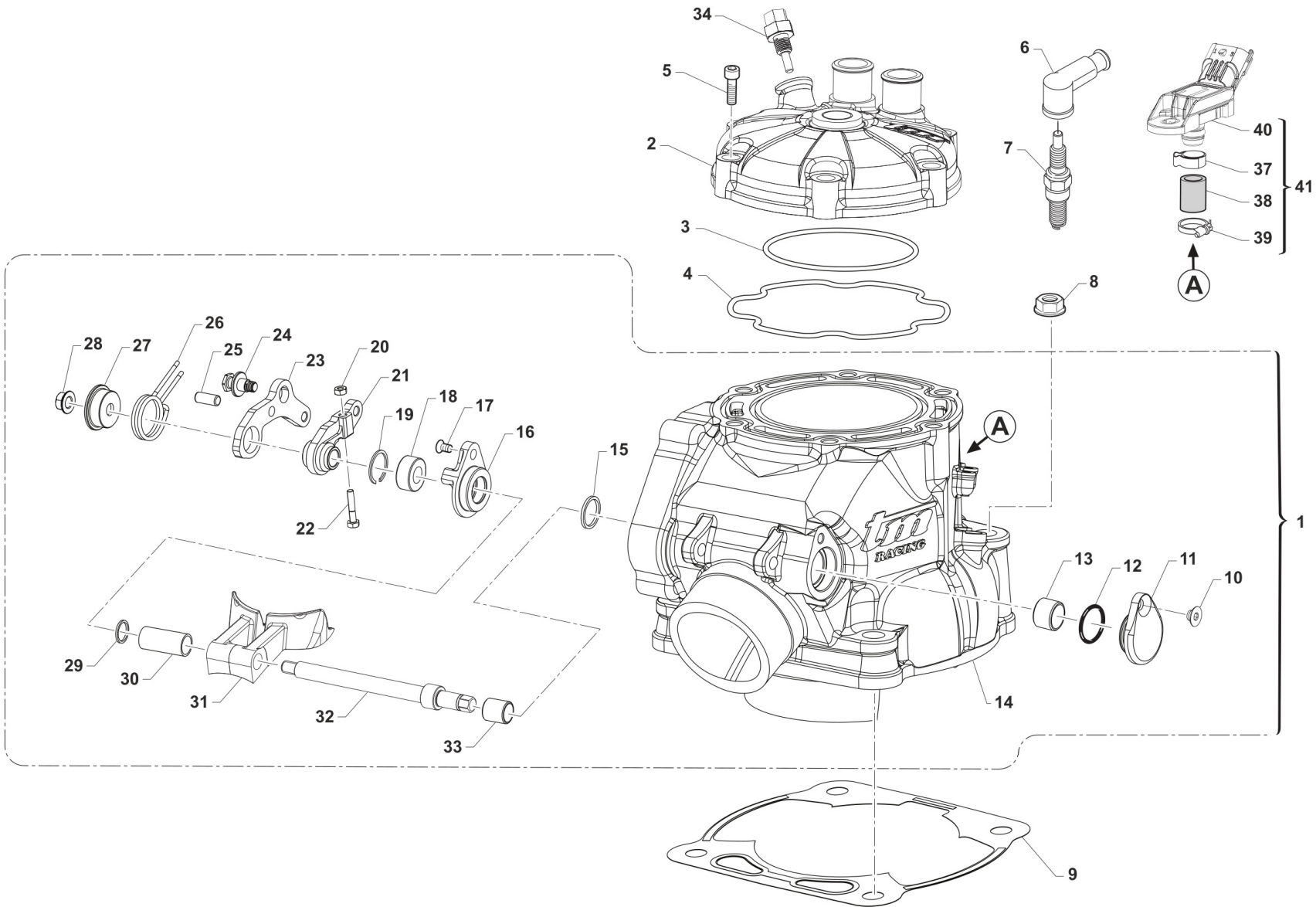

TM 0707



2T300FISMR25-M
2T 300 FI SMR - 2S 300 FI SMR

CILINDRO
CYLINDER

1

Pos.	Codice	Q.tà	Note	Descrizione	Description
1	01315.24	1		CILINDRO 300 2T IE CPL MY 24CON ALLOGGIAMENTO SENSORE	
2	02258	1		TESTA 2T 300 Fi	HEAD 300 T.S. F.I.
3	12262	1		O RING TESTA 300cc PICCOLO M.15->sostituito da 12262.1	O-RING 300 CC HEAD LITTLE M.15->
4	12263	1		O RING 250/300 SPECIALE TESTA M.15->	O-RING 250/300 HEAD BIG M.15
5	49503	8		VITE TCEI 8X35 UNI 5931-912 Brun	BOLT TCEI 8X35
6	21087	1		PIPETTA CANDELA SILICONE SCHERMATO 5K	
7	06036	1		CANDELA 250/300 2T M19-> NGK BKR8EIX	SPARK-PLUG 250/300 2S MY19-> BKR8EIX
8	F49874	4		DADO M 10 X 1,25 CH 12 FLANGIATO	NUT FLANGED M 10x1,25 T.12mm
9	05281.20	1		GUARN. B/CIL 300 sp. 0.2 M.15->	GASKET, CYL 300 M.15 0,2
9	05281.30	1		GUARN. B/CIL 300 sp. 0.3 M.15->	GASKET, CYL 300 M.15 0,3
9	05281.40	1		GUARN. B/CIL 300 sp. 0.4 M.15->	GASKET, CYL 300 M.15 0,4
9	05281.50	1		GUARN. B/CIL 300 sp. 0.5 M.15->	GASKET, CYL 300 M.15 0,5
10	49399	1		VITE TSEI 5X12	BOLT TSEI 5x12
11	30217	1		TAPPO SX ALB.COM.VALV.PAL.125	SIDE COVER
12	F12308	1		O RING 17,5 - 1,5	O-RING 17,5 - 1,5
13	19044	1		GABBIA A RULLI FRENO POST.	NEEDLE BUSH REAR BRAKE PEDAL
14	01314.24	1		CILINDRO 300 2T IE NUDO MY 24CON ALLOGGIAMENTO SENSORE	
15	04115	1		PARAOILIO G 12X18X3	OIL SEAL 12x18x3
16	26258	1		FLANGIA PORTACUSC. ALB.VALV.250/300 Fi 125/144 MY 20/24	FLANGE, BEARING HOLDER
17	49757	1		VITE TBCE 5 X 12	BOLT TBCE 5X12
18	03156	1		CUSCINETTO V.SC.C.12 698LLU/5K	BUSH, EXHAUST VALVE 698LLU
19	49220	1		SEEGER INT.19	SEEGER I 19
20	49630	1		DADO M 4 (BASSO)	NUT 4mm, LOW
21	28262	1		LEVA INTERNA COMANDO VALVOLE EES-2 250/300 2019	LEVER, INTERNAL, 250/300
22	49738	1		VITE TE 4X20	BOLT TE 4X20
23	28263	1		LEVA ESTERNA COMANDO VALVOLE EES-2	LEVER, EXTERNAL, VALVE



2T300FISMR25-M
2T 300 FI SMR - 2S 300 FI SMR

CILINDRO
CYLINDER

1

Pos.	Codice	Q.tà	Note	Descrizione	Description
24	26168	1		PERNO MOLLA EES-2 16066	PIN, SPRING
25	F19536	1		RULLO D. 5 X 12 M6 DIN 6325	PIN 5X12
26	16066	1		MOLLA EES-2	SPRING EES-2
27	26167	1		PIATTELLO GUIDA MOLLA EES-2 16066	COLLAR, SPRING
28	49676	1		DADO M 6X1 FLANG. AUTOBL.ACC.	NUT, FLANGED M6 X 1 S.B.
29	26130.12	1		SPESS. REG. CIL.125 2012 1.2	SPACER CYL. 125 ->12 1.2
29	26130.13	1		SPESS. REG. CIL.125 2012 1.3	SPACER CYL. 125 ->12 1.3
29	26130.14	1		SPESS. REG. CIL.125 2012 1.4	SPACER CYL. 125 ->12 1.4
29	26130.15	1		SPESS. REG. CIL.125 2012 1.5	SPACER CYL. 125 ->12 1.5
29	26130.16	1		SPESS. REG. CIL.125 2012 1.6	SPACER CYL. 125 ->12 1.6
29	26130.17	1		SPESS. REG. CIL.125 2012 1.7	SPACER CYL. 125 ->12 1.7
29	26130.18	1		SPESS. REG. CIL.125 2012 1.8	SPACER CYL. 125 ->12 1.8
29	26130.19	1		SPESS. REG. CIL.125 2012 1.9	SPACER CYL. 125 ->12 1.9
30	26147	1		BOCCOLA DIST. CIL. 250/300 2015 + 125 2020	BUSH
31	22262.19	1		VALVOLE SCARICO 300 ES MY 2019	POWER VALVE 300 2S ES MY19
32	28256	1		ALBERO COMANDO PALETTE 250	SHAFT BOOSTER 250/300
33	19061	1		BOCCOLA IR 8X12X12.5	BUSH, IR 1X12X12,5
34	08014	1		SENSORE TEMP. ACQUA TESTA 2T Fi MY19	SENSOR, WATER TEMPERATURE HEAD 250/300 2T Fi 19->
37	51107	1		FASCETTA OETIKER 018,5-706R	
38	67411.1	1		TUBO SENSORE 11x17 NERO 27 mm PRETAGLIATO	
39	16079	1		FASCETTA A MOLLA D 17	
40	68315	1		SENSORE PRESSIONE CARTER 2T INJ.	
41	68315.1	1		SENSORE PRESSIONE CARTER 2T INJ. CPL DI TUBO E FASCETTE	



2T300FISMR25-M
2T 300 FI SMR - 2S 300 FI SMR

MOTORINO VALVOLA
ELECTRIC VALVE SYSTEM

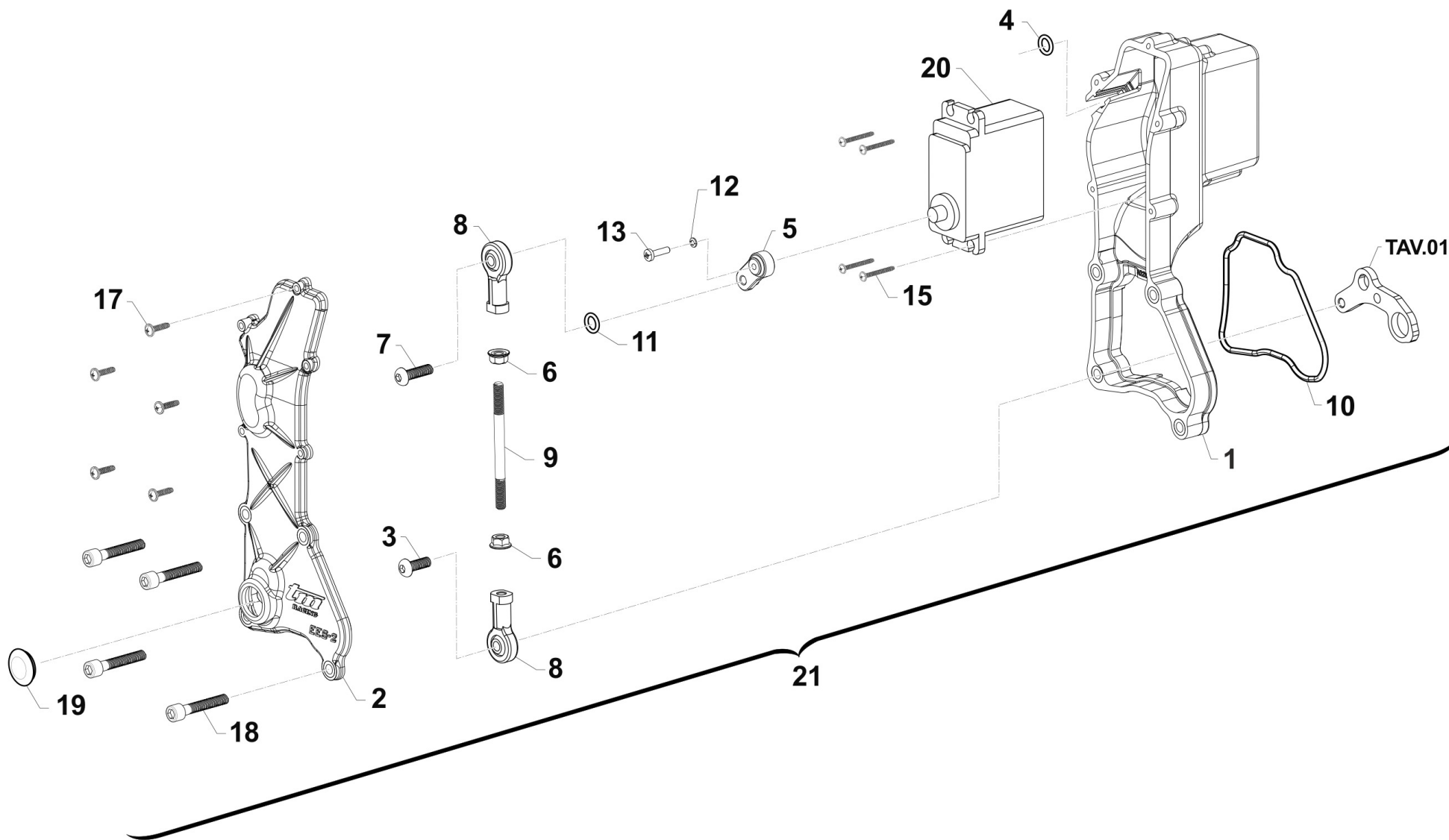

TM 0709



2T300FISMR25-M
2T 300 FI SMR - 2S 300 FI SMR

MOTORINO VALVOLA
ELECTRIC VALVE SYSTEM

2

Pos.	Codice	Q.tà	Note	Descrizione	Description
1	30285	1		CARTER EES-2 250/300 2T IE	BOX, PLASTIC
2	30286	1		COPERCHIO CARTER EES-2 250/300 2T IE	COVER, PLASTIC
3	49472	1		VITE TCEI 5X12 UNI 5931-912 Brun	BOLT TCEI 5X12
4	12060	1		O RING CAPICORDA CAVO FRIZIONE	O RING CLUTCH CABLE
5	28266.0	1		LEVA SERVOMOTORE EES-2 DENTATURA 0	LEVER
5	28266.1	1		LEVA SERVOMOTORE EES-2 DENTATURA 1	LEVER
6	49632	2		DADO M 5 x 0,8 ZB	NUT 5mm
7	49929	1		VITE 10.9 TBCEI 5 x 18 UNI 7380	BOLT
8	72251	2		SNODO MECCANISCO VALVOLA EES-2 125/250/300	JOINT EXHAUST VALVE EES-2 250/300
9	28264	1		ASTINA COLLEGAMENTO UNIBALL EES-2 250/300 2019	ROD UNIBALL EES-2 250/300 2S MY19->
10	12042	1		O RING COP. VALVOLA EES-2	O-RING
11	F12301	1		O RING 106 4T PIOGGIA CAMBIO	O-RING, 106 GEAR F.S.
12	49124	1		RONDELLA SCHNORR ZIG. 2.5	
13	49881	1		VITE T.C. 2,5X12	
15	49973	4		VITE STS-Plus KN6031 2.2X20 PLASTICA	BOLT
17	490021	5		VITE TCBL 3.0X 16 FL. X PLAST.	
18	49478	4		VITE TCEI 5X30 UNI 5931	BOLT TCEI 5X30
19	21009	1		TAPPO GOMMA COPERCHIO VALV.SC.	RUBBER, COVER
20	22500	1		SERVOMOTORE VALV.SCARICO HITEC	EL. ENGINE EXHAUST VALVE HITEC
21	22503.19	1		SERVOMOTORE V/SC. CPL 250/300 ES MY 2019	EL. ENGINE EXHAUST, ASSY

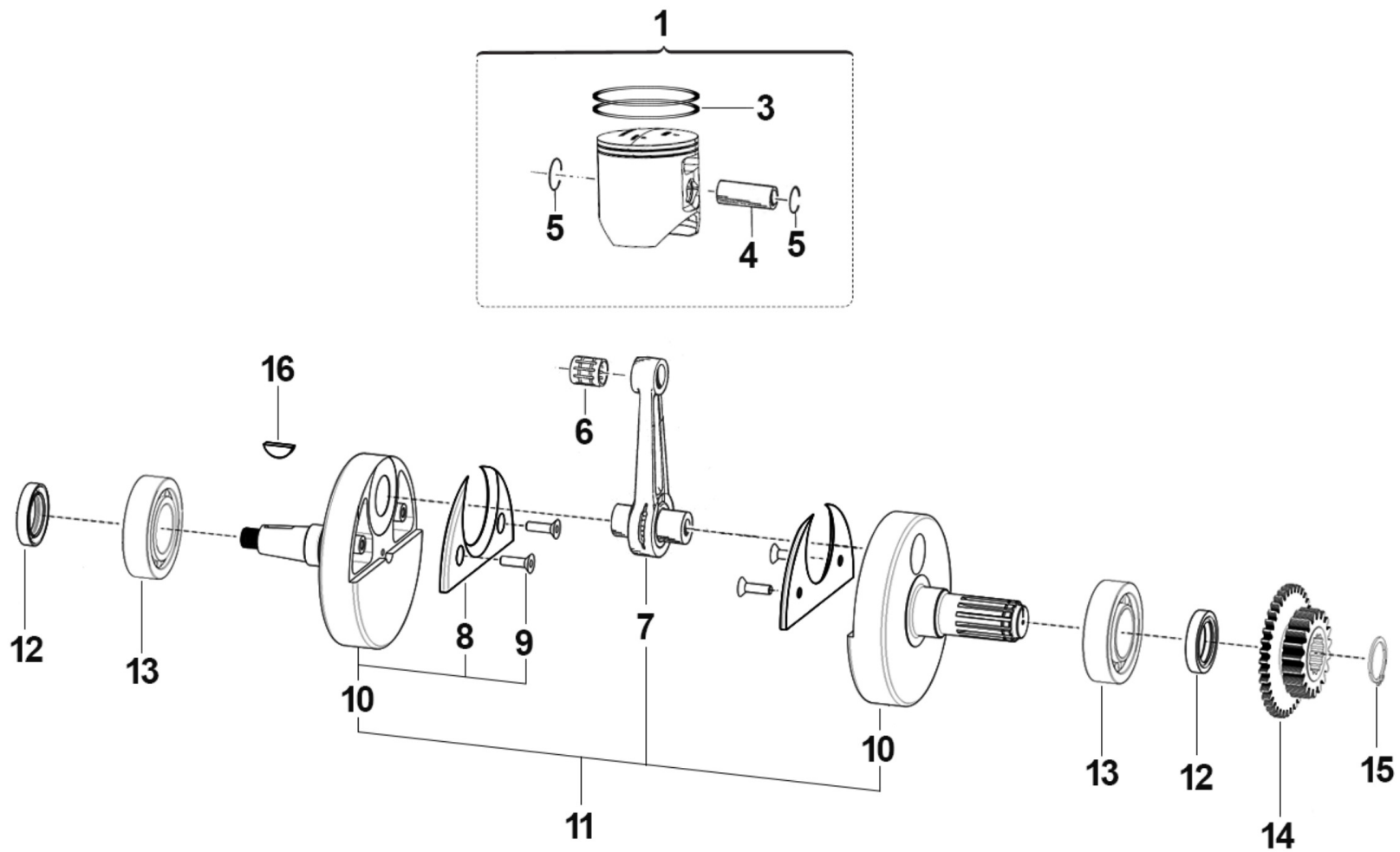



2T300FISMR25-M
2T 300 FI SMR - 2S 300 FI SMR

ALBERO MOTORE E PISTONE
CRANKSHAFT AND PISTON

3

Pos.	Codice	Q.tà	Note	Descrizione	Description
1	10305.94	1		PISTONE 71,94 2F 300 CPL M.19->	PISTON 71,94 T/Rings 300 ASSY 19->
1	10305.95	1		PISTONE 71,95 2F 300 CPL M.19->	PISTON 71,95 T/Rings 300 ASSY 19->
1	10305.96	1		PISTONE 71,96 2F 300 CPL M.19->	PISTON 71,96 2R 300 ASSY
3	11050	2		SEGMENTO 300cc VERTEX D. 72,00	PISTON RING 300cc VERTEX
4	09250	1		SPINOTTO PISTONE 250/300cc	PIN, PISTON 250/300cc
5	09251	2		ANELLINO FERMA SPINOT.250/300	CLIP, PISTON PIN 250/300
6	19250	1		GABBIA SPINOTTO 250/300 cc	TOP END BUSH 250/300cc
7	18246	1		BIELLA 250/300 M.05/-> P. CPL	CONROD KIT, 250/300 M.05/->
8	18270	2		GUANCETTA SEMIALB. 250/300Fi	STUFFERS, CRANKSHAFT
9	49404	4		VITE TSEI 6X16	BOLT TSEI 6x16
10	18268	1		COPPIA SEMIALBERI 250/300 EV18	CRANK LH + RH
11	18266.19	1		ALBERO MOTORE 250/300 2T ES MY 2019	CRANKSHAFT 250/300 2S FI MY.19
12	04112.1	2		PARAOLIO 25X38X7 FKM 250/300	
13	03051	2		CUSCINETTO 6206 - Z/C4	
14	40282	1		PIGNONE C.PRIM.250/300 Z20 PER CONTRALBERO	
15	49252	1		SEEGER PIGNONE CATENA 250 E 25	CIRCLIP D.25 FRONT SPROKET 250
16	49012	1		CHIAVETTA PIGNONE COPPIA 250	WOODRUFF KEY, 250/300 19x7,5x5



2T300FISMR25-M
2T 300 FI SMR - 2S 300 FI SMR

LATO CARTER FRIZIONE
CLUTCH CASE SIDE

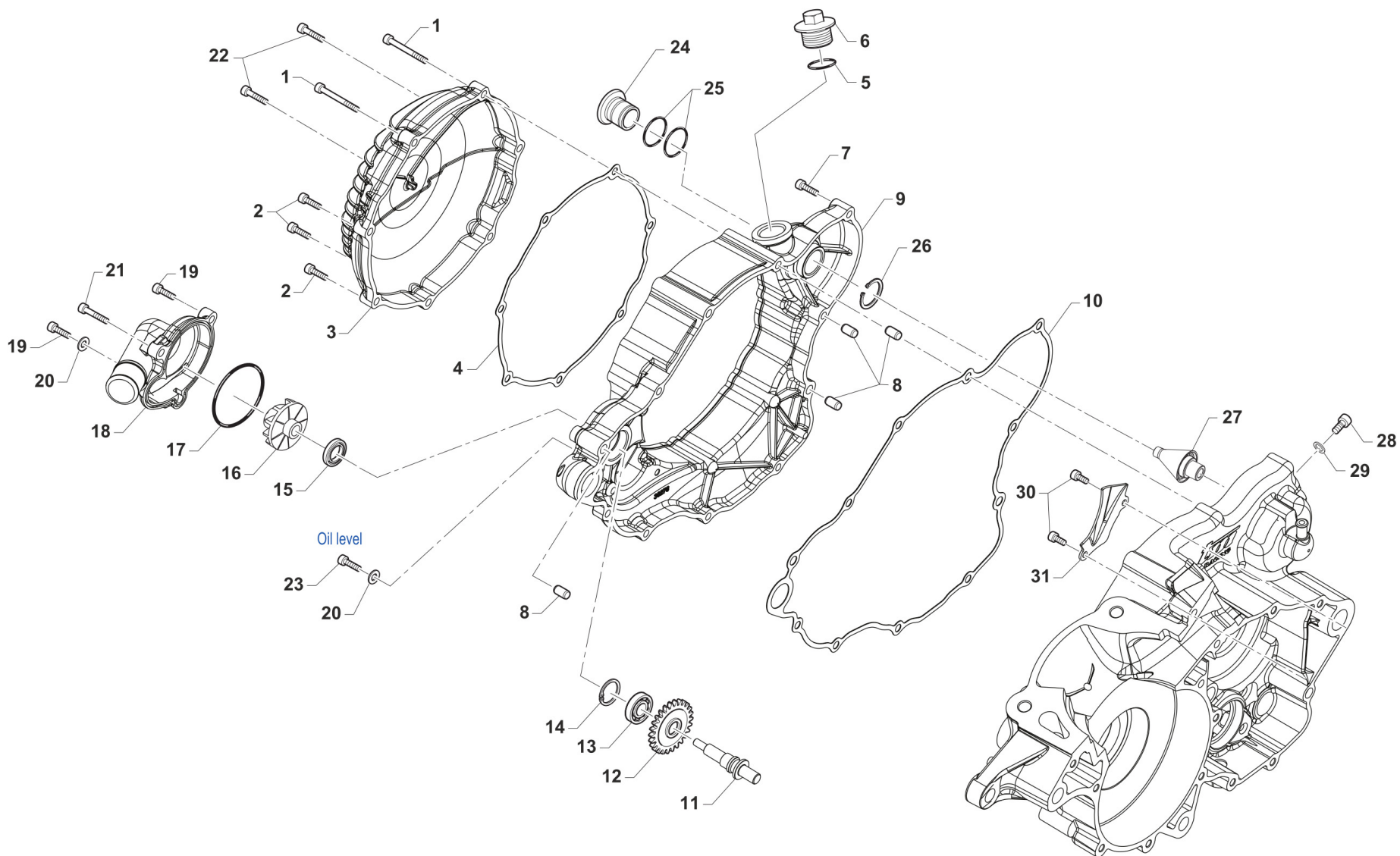

TM 0200



2T300FISMR25-M
2T 300 FI SMR - 2S 300 FI SMR

LATO CARTER FRIZIONE
CLUTCH CASE SIDE

4

Pos.	Codice	Q.tà	Note	Descrizione	Description
1	49986	2		VITE TCEI 5X75	BOLT TCEI 5 X 75
2	49477	3		VITE TCEI 5X25 UNI 5931-912	BOLT TCEI 5X25
3	30277	1		COPERCHIO FRIZIONE 250/300 2T MY'19	COVER, CLUTCH 250/300 TS M.19->
4	05284	1		GUARN. COP. FRIZIONE 250/300 2T ES M19->	GASKET, CLUTCH COVER 250/300 2S ES MY 19
5	F49920	1		RONDELLA ALL 20.4X26X1.5	WASHER 20,4X26X1,5 ALUM.
6	F49925	1		TAPPO CARICO OLIO M20X1.5	OIL PLUG M20X1,5
7	49477	9		VITE TCEI 5X25 UNI 5931-912	BOLT TCEI 5X25
8	26041	4		GRANO CENTRAGGIO D.7X8 F.5,2	DOWEL PIN 7 x 8 Hole 5,2
9	30288	1	MY20	CARTER FRIZIONE 250/300 2020	COVER, INTERNAL, CLUTCH
10	05285	1	MY20	GUARN. CARTER INT. FRIZ. 250/300 2T ES MY 2020	GASKET, INT. CLUTCH COVER 250/300 2T ES M 20->
11	28068	1		ALBERINO POMPA ACQUA 250 SC.	SHAFT WATER PUMP 250
12	40080	1		INGR COMANDO POMPA H2O 250 Z18	
13	03014	1		CUSCINETTO 608 ZC3 POMPA SCHER	BUSH, WATER PUMP 608 Z C3
14	49215	1		SEEGER I22 POMPA ACQUA	CIRCLIP D.22 WATER PUMP
15	F04363	1		PARAOLIO 8X22X5 250/09->	OIL SEAL 8x22x5 (250F/09)
16	F28679	1		GIRANTE POMPA ACQUA 250N	IMPELLER, H2O PUMP 250Fi
17	12028	1		OR COP. POMPA H2O 2T 250/300 M.18->	O-RING WATER PUMP COVER 2S 250/300 MY.18->
18	30275.20	1		COPERCHIO POMPA ACQUA 250/300 2T Fi MY 2020	COVER, WATER PUMP 250/300 2S ES MY 2019
19	49476	2		VITE TCEI 5X20 UNI 5931	BOLT TCEI 5X20
20	49119	2		RONDELLA 5 x 9 x 1,5 ALLUMINIO	WASHER, 5 x 9 x 1.5 ALLUMINIUM
21	49570	1		VITE TCEI 5X50 UNI 5931	SCREW TCEI 5X50
22	49478	2	MY20	VITE TCEI 5X30 UNI 5931	BOLT TCEI 5X30
23	49472	1		VITE TCEI 5X12 UNI 5931-912 Brun	BOLT TCEI 5X12
24	26234	1		TAPPO FORO ALBERINO M/M 250/300 4T	
25	12092	2		O RING NBR14x2 REGISTRO ALTE VELOCITA'	
26	F49914	1		SEEGER E 18	CIRCLIP E D.18
27	32002	1		SEPARATORE ARIA OLIO 2T	
28	49558	1		VITE TCEI 8X10	



2T300FISMR25-M
2T 300 FI SMR - 2S 300 FI SMR

LATO CARTER FRIZIONE
CLUTCH CASE SIDE

4

Pos.	Codice	Q.tà	Note	Descrizione	Description
29	F49939	1		RONDELLA RAME 8 X13 X 1,5	WASHER COPPER 8,5X13X1,5
30	49580	2		VITE TCEI 4X10 5931-912 Brun	BOLT
31	26162	1		PIASTRINO CONV.OLIO 250/300 18	PLATE



2T300FISMR25-M
2T 300 FI SMR - 2S 300 FI SMR

FRIZIONE 6M
CLUTCH 6 SPEED

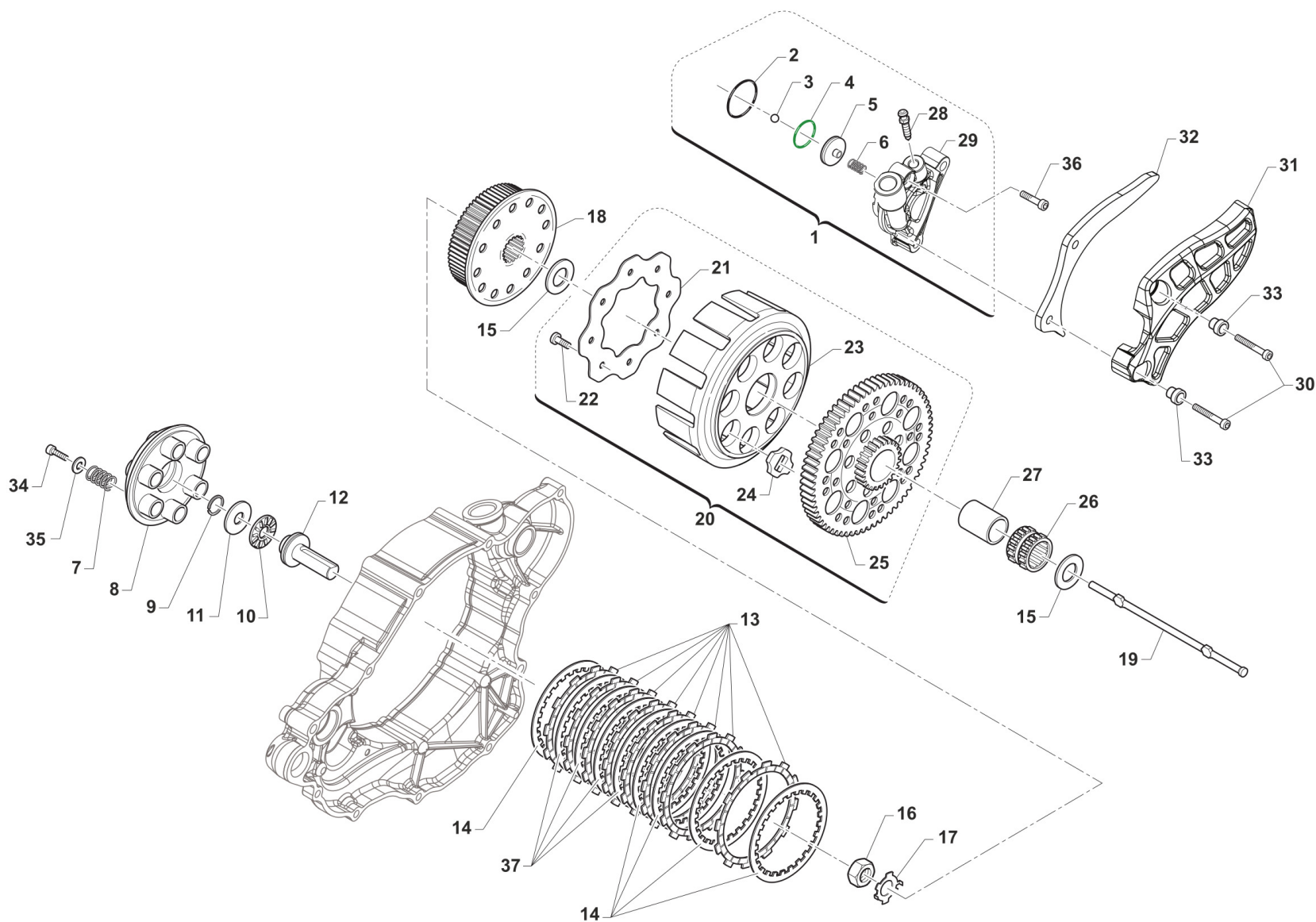

TM 0135.12



2T300FISMR25-M
2T 300 FI SMR - 2S 300 FI SMR

FRIZIONE 6M
CLUTCH 6 SPEED

Pos.	Codice	Q.tà	Note	Descrizione	Description
1	30265.19	1		COP. FRIZ/IDR 2T 250/300 ES MY 2019 CPL	COVER IDR.CLUTCH 250/300 T.S. ES MY19-> ASSY
2	12091	1		O RING CORPO CARTUCCIA FR.COMP	O-RING
3	F19517	1		SFERA X PIST.FRIZ.IDRAUL.250N	BALL IDR. CLUTCH PISTON 250N
4	12268	1		O RING PISTONE FRIZ.250/300 2T 19 VERDE	O-RING CLUTCH PISTON 250/300 TS M.19->
5	F35559	1		PISTONCINO CIL.FRIZ.D.27XRING	PISTON
6	F16470	1		MOLLA CONTR. PIST/FRI 450Fi'15	
7	F16453	6		MOLLA FRIZIONE 2/4T 250/450	SPRING, CLUTCH 2/4T 250/450
8	25253	1		PIATTO SPING. 250/300 + 4T	PLATE, CLUTCH PRESSURE
9	09006	1		ANELLINO FERMA SPINOTTO 80/85/100	CLIP, PISTON PIN 80/85/100cc
10	19022	1		GABBIA A RULLI RAD. AXK 1528	BUSH CAGE AXK 1528, RADIAL
11	19023	1		RONDELLA GABBIA RULLI AS 1528	WASHER, NEEDLE CAGE AS 1528
12	F35582	1		FUNGO FRIZIONE IDRAULICA 2015	PIECE, CLUTCH LIFTER
13	F35589	8		DISCO FRIZIONE 141-E7G02-00 2T/4T FCC	CLUTCH FRICT. PLATE 141-E7G02-00 2S/4S FCC
14	35069	5		DISCO FRIZ. ACC. 1,2 mm 2T 250/300 + 4T 450/530 C67	
15	48250	2		SPESSORE COPPIA PRIMARIA 250	SPACER, PRIMARY GEAR 250cc
16	49060	1		DADO TAMBUR.FRIZ. ALB.PRIM. 250/300 M18X1.5	NUT, CLUTCH CENTER 250cc
17	35050	1		RONDELLA X FRIZ. 250/300/4T	CLUTCH WASHER 250/300/F
18	25255	1		TAMBURELLO FRIZIONE 250/300 2T ES MY 2019	CENTRAL HUB
19	35503	1		ASTINA FRIZIONE IDRAULICA 250/300 IE M19	ROD, CLUTCH
20	40245.21	1		COPPIA PRIM. 250/300 2T ES z57 CPL 6 MARCE	
21	35262.1	1		DISCO BATTUTA GOMMINI FRIZ. 2T/4T F.7 MMPER VITI 49727	
22	49727	8		VITE PARASTRAPPI K9 M7X1X12.5	SCREW, M7X1X12,5 K9 ENGINE
23	25254	1		CAMPANA FRIZIONE 250 / 300 M.19->	CLUTCH BASKET 250/300 MY 19->
24	21005	8		GOMMINO PARASTRAPPI FRIZIONE	RUBBER, CLUTCH BASKET
25	40283	1		CORONA COPPIA PRIM. 250/300 2T ES Z57 PER PIGNONE Z20	
26	F19510	1		GABBIA A RULLINI K 27X32X23.8	NEEDLE CAGE 27 x 32 x 23.8



2T300FISMR25-M
2T 300 FI SMR - 2S 300 FI SMR

FRIZIONE 6M
CLUTCH 6 SPEED

5

Pos.	Codice	Q.tà	Note	Descrizione	Description
27	F26422	1		BOCCOLA INGR.TRASM.PRIM. 250N	BUSH, PRIMARY GEAR 250Fi
28	35264	1		VITE SPURGO OLIO FRIZ.IDR.6X1	SCREW AIR BLEED HYDRAUL.CLUTCH
29	30269	1		COP. FRIZ/IDR NUDO 250/300 M19	COVER IDR. CLUTCH 2S 250/300 MY19->
30	49535	2		VITE TCEI 5X35 UNI 5931-912 Brun	BOLT TCEI 5X35
31	40075	1		PROTEZIONE PIGNONE 250/300 IE	PROTECTION, PLASTIC
32	40042	1		PROTEZIONE PIGNONE ERGAL 250/300 2T ES MY 2019	PROTECTION, ERGAL
33	26211	2		BOCCOLA PROT. PIGNONE 250 F.5	COLLAR, SPROCKET 250cc H.5
34	49484	6		VITE TCEI 6X20	BOLT TCEI 6X20
35	49604	6		RONDELLA 6 X18 X 1,6	WASHER 6x18
36	49474	1		VITE TCEI 5X16 UNI 5931	BOLT TCEI 5X16
37	35071	4		DISCO FRIZ. ACC. 1,0 mm 2T 250/300 + 4T 450/530 C67	

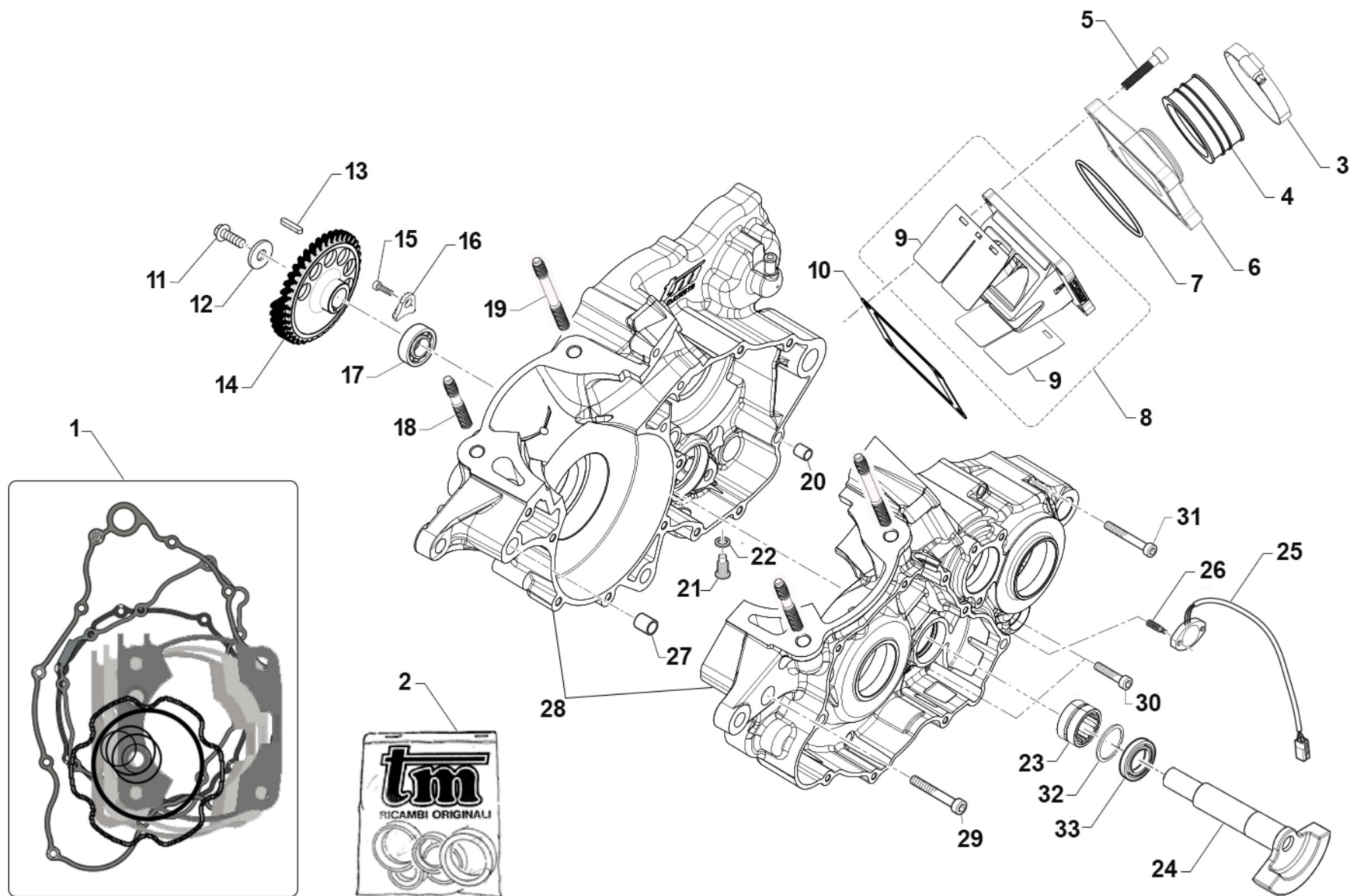



2T300FISMR25-M
2T 300 FI SMR - 2S 300 FI SMR

BASAMENTO E CONTRALBERO

6

Pos.	Codice	Q.tà	Note	Descrizione	Description
1	05620.20	1	MY20	KIT GUARNIZIONI + OR 300cc 2T ES MY 2020	GASKETS KIT + OR 300 2S ES MY 2020
2	04029.19	1		KIT PARAOLI 250/300 2T ES MY 2019	OIL SEAL KIT 250/300 2T ES MY 2019
3	51054	2		FASCETTA SM9 D.52	CLAMP SM9 D.52mm
4	13009	1		MANICOTTO COLLETTORE ASP.97/14	MANIFOLD RUBBER,INTAKE M.97/14
5	49486	4		VITE TCEI 6X30 UNI 5931	BOLT TCEI 6X30
6	30314.14	1		CONVOGL. P/LAM 250/3 14/-> VF3	MANIFOLD, INTAKE
7	12255	1		O RING COLLETT.ASP.250/300 14	O-RING, INLET MANIFOLD 250/300
8	20258	1		PACCO LAM 250/300 VF3 07/->	REEDS BOX VF3 250/300 M. 07/->
9	20076	1		LAMELLE V-FORCE3 250/300 07/->	REEDS, V-FORCE3 250/300 07/->
10	05268	1		GUARN. PACCO LAMELLE 250	GASKET, REED BLOCK 250/300
11	49363	1		VITE TE F/R 8X16 Ch.10	BOLT 8X16 T.10mm
12	49619	1		RONDELLA 24 x 3 F. 8/8.5	
13	49969	1		CHIAVETTA CONTRALBERO 250/300 2T A 3X3X12	WOODRUFF KEY
14	40257	1		INGR. CONTRALBERO 250/300 M18	GEAR, BALANCE SHAFT
15	49962	1		VITE TCEI 6X12 BASSA / F.GUIDA	BOLT
16	26156	1		PIASTRINO BLOC.CUSC.C.A.125 OK /250/300	PLATE, BEARING HOLDER 125 OK
17	03049	1		CUSCINETTO CONTRALBERO MOTO 2T	BUSH, COUNTERSHAFT 2S BIKE
18	49044	2	MY20	PRIGIONIERO CARTER/CILIND.250/300 ES Ant.	STUD, M10 X 1.25 L.57
19	49045	2	MY20	PRIGIONIERO CARTER/CILIND. 250/300 ES Post.	STUD, M10 X 1.25 L.81,5
20	F26304	1		GRANO RIFERIMENTO 6.5X8X9.5 4T	GRUB SCREW 6.5X8XX9.5 4S
21	49301	1		TAPPO OLIO C/CALAM. 2T	OIL PLUG WITH MAGNET
22	49103	1		RONDELLA 14X20X1,5 ALLUMINIO	WASHER, 14 X 20 X 1.5 ALUMINUM
23	19078	1		ASTUCCIO A RULLI NK 2020 C/ALB. 250/300 2T I.	
24	18267	1		CONTRALBERO 2T 250/300 ES MY 2019	BALANCE SHAFT
25	F08459	1		SENSORE POSIZIONE CAMBIO eM060 CPL G.ANTIORARIO	
26	49713	2		GRANO 6X20 SENSORE CAMBIO 2T 250/300	GRUB SCREW
27	F26428	1		GRANO RIFERIMENTO 12X13 F10.2	GRUB SCREW 12X13 H.10,2mm
28	30300.20	1		BASAMENTO MOTORE 300 2T ES MY 2020	CRANKCASE ASSY 300 2S ES MY 20->



2T300FISMR25-M
2T 300 FI SMR - 2S 300 FI SMR

BASAMENTO E CONTRALBERO

6

Pos.	Codice	Q.tà	Note	Descrizione	Description
29	49508	1		VITE TCEI 8X60 UNI 5931	BOLT
30	49487	3		VITE TCEI 6X35 UNI 5931	BOLT TCEI 6X35
31	49490	11		VITE TCEI 6X50 UNI 5931	BOLT TCEI 6X50
32	49274	1		SEEGER JV 30	
33	04035	1		PARAOLIO 20x30x7 PTFE	OIL SEAL 20 x 30 x 7 PTFE



2T300FISMR25-M
2T 300 FI SMR - 2S 300 FI SMR

FORCHETTE CAMBIO 6M

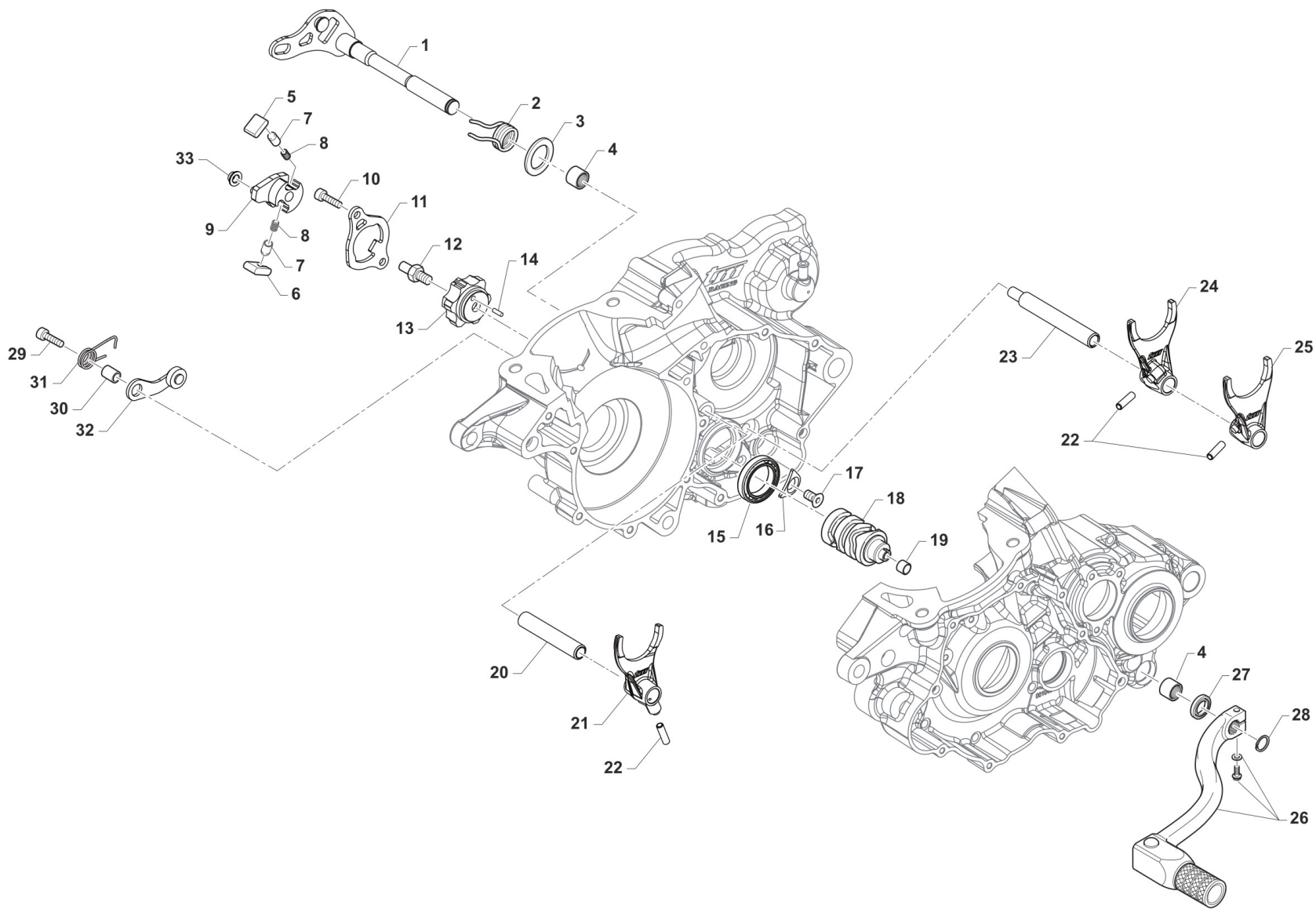

TM 0710



2T300FISMR25-M
2T 300 FI SMR - 2S 300 FI SMR

FORCHETTE CAMBIO 6M

Pos.	Codice	Q.tà	Note	Descrizione	Description
1	28105	1		ALBERO COMANDO CAMBIO 250/300 IE CPL	SHAFT, GEARSHIFT 250/300 IE CPL
2	16065	1		MOLLA RITORNO LEVA CAMBIO 250 2T IE	SPRING, RETURN GEAR LEVER 250 2S EI
3	49073	1		RONDELLA 12,1X22X1	WASHER 12,1X22X1 125 MF1/2
4	19060	2		ASTUCCIO A RULLI HK 1212	NEEDLE CAGE HK 1212
5	F26587	1		CRICCHETTO SX 2T 250/300 ES	RATCHET, LF GEAR (HT) 250 M3
6	F26588	1		CRICCHETTO DX 2T 250/300 ES	RATCHET, RH GEAR (HT) 250 M3
7	F26592	2		PUNTALE CRICCHETTO 2T 250/300 ES	PIN, RATCHET GEAR (HT)
8	F16469	2		MOLLA PER PUNTALE 2T 250/300 ES	SPRING, GEARBOX PIN EDM
9	F26620	1		PORTACRICCHETTI HT 2T 250/300 ES	GEAR
10	49482	2		VITE TCEI 6X14 UNI 5931	BOLT TCEI 6X14
11	26160	1		PIASTRINO RIENTRO CRIC.250 M18	PLATE
12	F49873	1		PERNO FILETTATO PORTACRICCHETTI (HT) 2T 250/300 ES	THREADED PIN FOR RATCHET HOLDER (HT)
13	26179	1		TESTA ALBERO DESMO ROT.D12 250/300 2T M22	
14	F19504	1		RULLO D.4 X 8	PIN D.4 X 8
15	F03381	1		CUSCINETTO 61805	BUSH 61805
16	F48352	1		PIASTRINO FISSA CUSCINETTO D72	PLATE
17	49403	1		VITE TSEI 6X12 ZINCATO	SCREW TSEI 6x12
18	33254	1		ALBERO DESM. 250/300 2T 6M CPL (2020)COMPLETO DI 26164	
19	26260	1		BOCCOLA ALB. DESMODROMICO 250/300 2T I.E.	BUSH
20	33260	1		PERNO FORCHETTA AP 250/300 MY19	PIN, MAINSHAFT FORK
21	33026	1		FORCHETTA ALB.PRIM. 250/300 2T 6M 5^/6^ (2020)	
22	F19533	3		RULLO D.6 X 15	PIN
23	33025	1		PERNO FORCHETTA AS 250/300 MY19	PIN, COUNTERSHAFT FORKS
24	33023	1		FORCHETTA A.S.1^3^ 250/300 M18 1A E 3A	FORK 1, COUNTERSHAFT
25	33027	1		FORCHETTA ALB.SEC. 250/300 2T 6M 2^/3^ (2020)	
26	43049	1		LEVA CAMBIO 2T (485) MY19->	GEAR LEVER 250 / 300 T.STR. EL.ST. M.19->
27	04038	1		PARAOILIO LEVA CAMBIO 250/300 2T I 12x20x5 l.parapolv.	OIL SEAL GEAR LEVEL 250/300 2S Fi 12x20x5



2T300FISMR25-M
2T 300 FI SMR - 2S 300 FI SMR

FORCHETTE CAMBIO 6M

7

Pos.	Codice	Q.tà	Note	Descrizione	Description
28	49212	1		SEEGER E12 LEVA CAMBIO	CIRCLIP D.12 - EXTERNAL
29	49485	1		VITE TCEI 6X25 UNI 5931	BOLT TCEI 6x25
30	26007	1		DISTANZIALE MOLLA BLOCCAMARCE	SPACER, STOP GEAR SPRING
31	F16447	1		MOLLA BLOCCA MARCE 250N SOSTITUITA DA F16447.3	SPRING, STOP GEAR 250 4S
32	26095	1		PIASTRINO BLOCCAMARCE KV/95CPL + MOTO	PLATE, STOP GEAR KV/95 ASSY
33	F26593	1		BOCCOLA FLANGIATA PORTACRICCHETTO F26620	LEVER BUSH



2T300FISMR25-M
2T 300 FI SMR - 2S 300 FI SMR

CAMBIO 6M
GEAR BOX

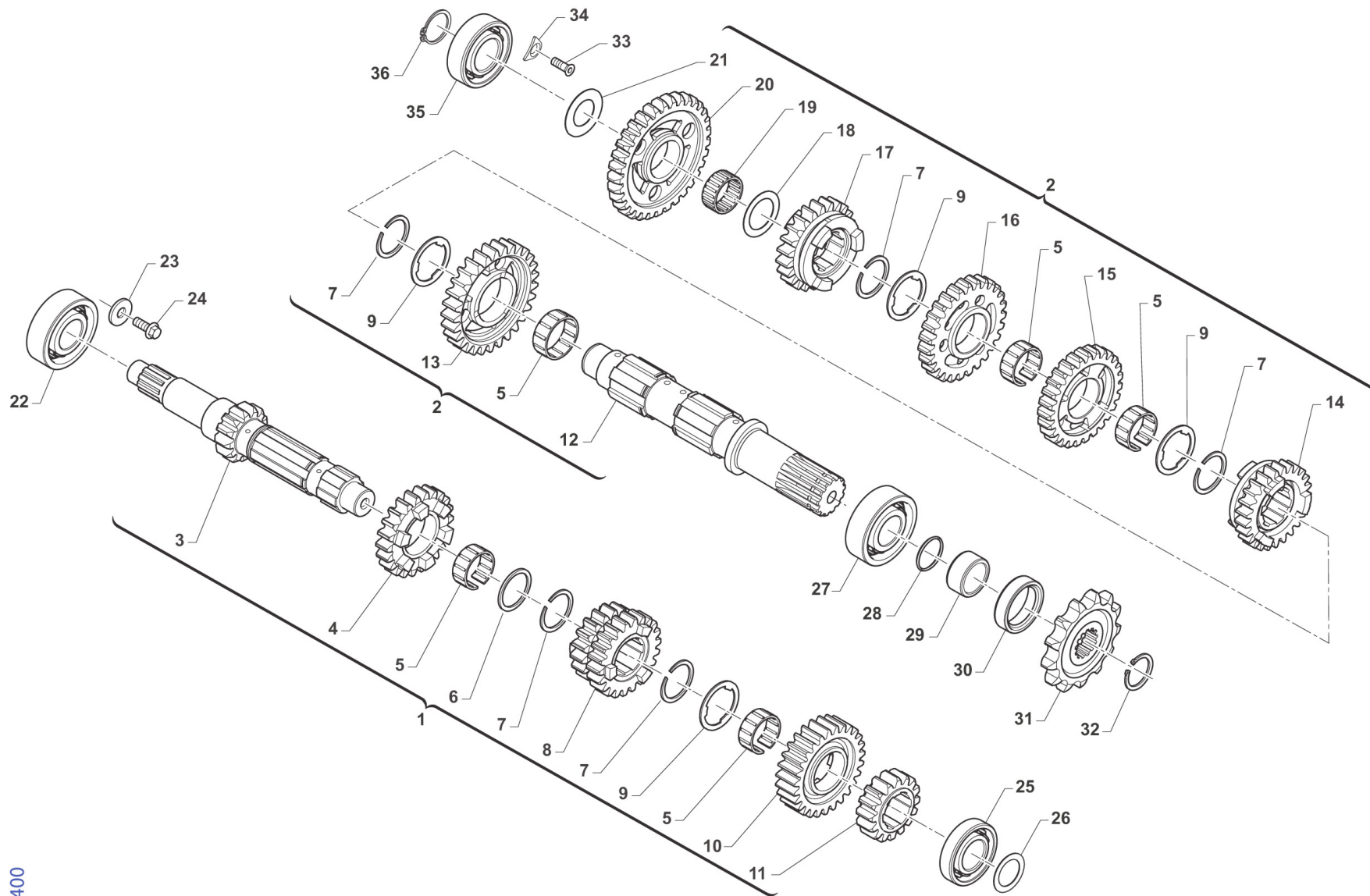

TM400



2T300FISMR25-M
2T 300 FI SMR - 2S 300 FI SMR

CAMBIO 6M
GEAR BOX

8

Pos.	Codice	Q.tà	Note	Descrizione	Description
1	40320	1		ALBERO PRIMARIO EN CPL 250/300 2T ES 6 MARCE	
2	40321	1		ALBERO SECONDARIO EN CPL 250/300 2T ES 6 MARCE	
3	40736	1		ALBERO PRIMARIO Z13 250/300 2T 6M EN MY21	
4	40739	1		INGR A.P. 5^ Z18 6M EN 250/300 2T 450 4T MY21	
5	F19524	5		GABBIA A RULLI 22X26X10 TAGL.	NEEDLE BEARING 22 X 26 X 10
6	48259	1		SPESSORE D.25.1 x 31 x 1.5 CAMBIO INT.55 6M	
7	F49869	5		SEEGER SW 24 (EST.) "SEEGER"	CIRCLIP SW 24 (EXTERNAL)
8	40738	1		INGR A.P. 3^/4^ Z19/20 6M EN 250/300 2T 450 4T MY21	
9	48258	4		SPESSORE DENT.CAMBIO INT.55 6M	SPACER GEAR INT.55 6S
10	40740	1		INGR A.P. 6^ Z23 6M EN 250/300 2T 450 4T MY21	
11	40737	1		INGR A.P. 2^ Z16 6M EN 250/300 2T 450 4T MY21	
12	40741	1		ALBERO SECONDARIO 250/300 2T 6M MY21	COUNTERSHAFT 250/300 TS 6S MY21->
13	40743	1		INGR A.S. 2^ Z26 6M EN 250/300 2T 450 4T MY21	
14	40747.1	1		INGR A.S. 6^ Z18 6M EN 250/300 2T 450 4T INN.MOD. MY21	
15	40744.1	1		INGR A.S. 3^ Z24 6M EN 250/300 2T 450 4T INN.MOD. MY21	
16	40745	1		INGR A.S. 4^ Z21 6M EN 250/300 2T 450 4T MY21	
17	40746	1		INGR A.S. 5^ Z16 6M EN 250/300 2T 450 4T MY21	
18	48252	1		SPESSORE CAMBIO 20X29X1 250	SPACER, GEAR 250 20X29X1
19	19012	1		GABBIA A RULLI K 20X24X10	BUSH NEEDLE CAGE 20 X 24 X 10
20	40742	1		INGR A.S. 1^ Z30 6M EN 250/300 2T 450 4T MY21	
21	48059	1		Spessore alb.sec. 2T IE 17x28x3.5	SPACER
22	03252	1		CUSCINETTO 6205 C4 A/P 250/K9	BUSH, MAINSHAFT 250 / KZ
23	49603	1		RONDELLA M 6,4 X 12 X 1,6	WASHER 6x12
24	49962	1		VITE TCEI 6X12 BASSA / F.GUIDA	BOLT
25	F03379	1		CUSCINETTO 16004 C3	BUSH 16004 C3
26	F48401.30	1		RASAMENTO Ø20,3 x Ø35,9 x 0,30	SHIM
27	03020	1		CUSCINETTO RULLI NJ205ET2XC3 (BANCO 85/100 M.18)	BUSH CRANKSHAFT 85/100->18 NJ205ET2XC3
28	12252	1		O RING PIGNONE CAT.+DIS.AL.MOT	O-RING, 25,12 x 1,78



2T300FISMR25-M
2T 300 FI SMR - 2S 300 FI SMR

CAMBIO 6M
GEAR BOX

8

Pos.	Codice	Q.tà	Note	Descrizione	Description
29	26261	1		DISTANZIALE PIGNONE CAT.250/300 2T 19	SPACER SPROCKET DRIVE 250/300 T.S. MY19->
30	04101	1		PARAOLIO PIGNONE CATENA 250	OIL SEAL 40 x 30 x 7
31	40212	1		PIGNONE CATENA Z12 250	SPROCKET 12T, DRIVE 250/300/4T
31	40214	1		PIGNONE CATENA Z13 250/2T e 4T	SPROCKET 13T, DRIVE 250/300/4T
32	49252	1		SEEGER PIGNONE CATENA 250 E 25	CIRCLIP D.25 FRONT SPROKET 250
33	49403	1		VITE TSEI 6X12 ZINCATO	SCREW TSEI 6x12
34	F48352	1		PIASTRINO FISSA CUSCINETTO D72	PLATE
35	03251	1		CUSCINETTO 6203/C3 A/P A/S 250	BUSH, MAINSHAFT COUNTER.250/4T
36	F49876	1		SEEGER E 17 X 1,5 CAMBIO 250/300 2T 19->	CIRCLIP E 17 GEAR BOX 250/300 2S MY.19->

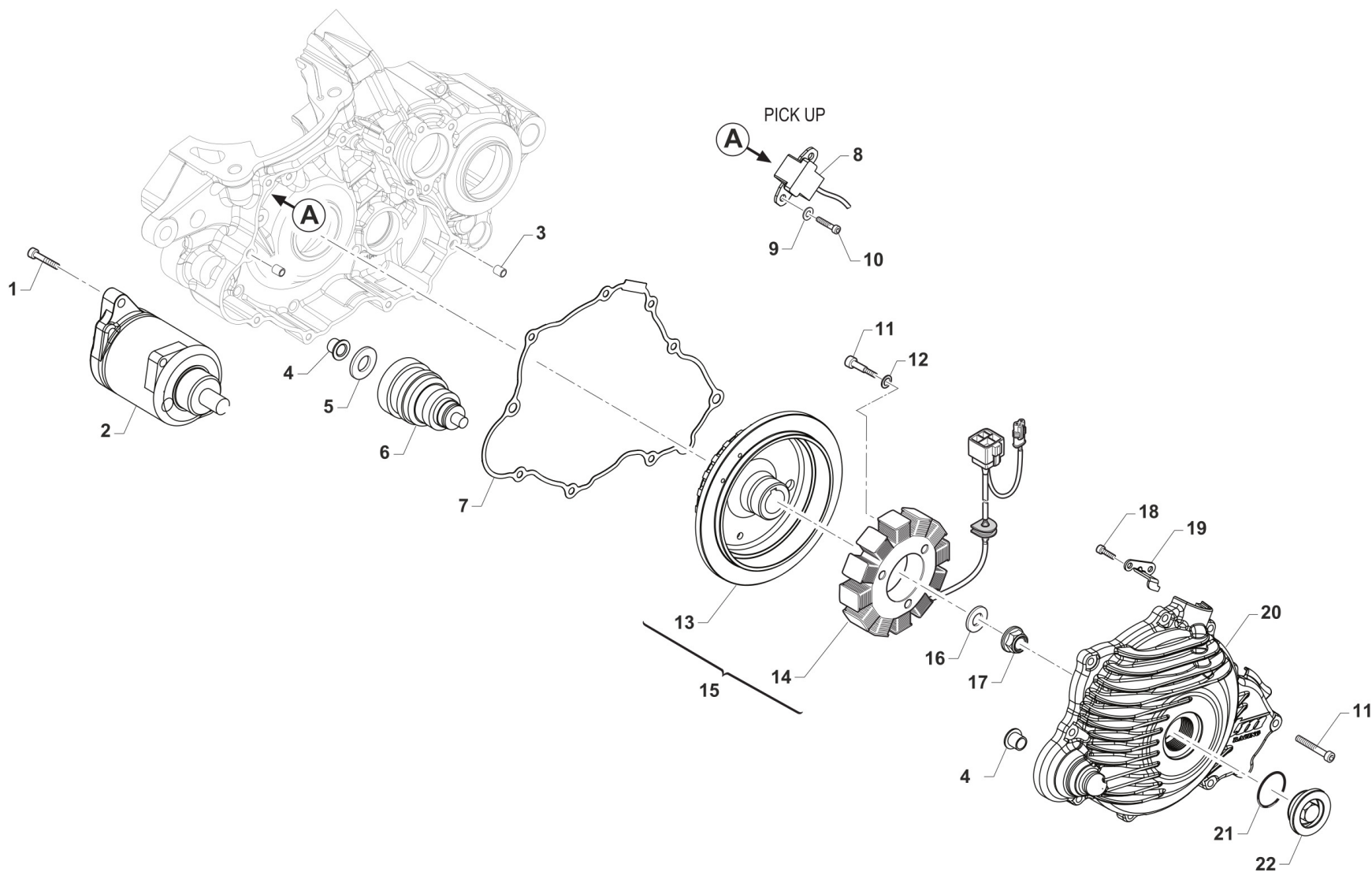



2T300FISMR25-M
2T 300 FI SMR - 2S 300 FI SMR

ACCENSIONE
IGNITION

10

Pos.	Codice	Q.tà	Note	Descrizione	Description
1	49485	2		VITE TCEI 6X25 UNI 5931	BOLT TCEI 6x25
2	68206	1		MOTORINO AVVIAMENTO 250/300 M18->	STARTER MOTOR 250/300 T.S. MY19->
3	26041	2		GRANO CENTRAGGIO D.7X8 F.5,2	DOWEL PIN 7 x 8 Hole 5,2
4	26256	2		BOCCOLA FLANGIATA BENDIX AVV. EL. 250/300 2T I.E.	FLANGE BUSH BENDIX EL.ST. 250/300 T.S. Fi
5	72418.23	1		LAMELLA D.8 23-020	
6	68207	1		BENDIX MOTORE 250/300 2T ES MY 2019	BENDIX
7	05260	1		GUARN. COP. ACC. 250/300 2T ES M19->	GASKET, IGNITION COVER 250/300 2S ES MY 19
8	F15478	1		PICK-UP KOKUSAN	PICK-UP KOK PU5157
9	49601	2		RONDELLA 5X11	WASHER 5x11
10	49472	2		VITE TCEI 5X12 UNI 5931-912 Brun	BOLT TCEI 5X12
11	49477	12		VITE TCEI 5X25 UNI 5931-912	BOLT TCEI 5X25
12	49615	3		RONDELLA ACCIAIO 5x11x0,5	WASHER STEEL 5 mm
13	15247	1		ROTORE X GEN. ES 250/300 2T IE CPL M.19-> in C45	ROTOR, INGNITION 250/300 2T ES MY 2019
13	F50816	1		ESTRATTORE ACC KOK 125Fi + 250/300 2T ES 19->	FLYWHEEL PULLER KOKUSAN 250/300 2S MY.19->
14	F15551	1		STATORE KOKUSAN YS 9022	STATOR KOKUSAN YS 9022
15	15255	1		ACCENSIONE CPL 250/300 2T ES MY 201915247 + F15551	IGNITION ASSY 250/300 T.S. ES MY 19->
16	49613	1		RONDELLA ACCIAIO 12	STEEL WASHER 12
17	49056	1		DADO ACCENSIONE MX/E 12 x 1.25	NUT, IGNITION 100cc
18	49580	2		VITE TCEI 4X10 5931-912 Brun	BOLT
19	F30945	1		PROTEZIONE CAVI ACC.NE 250N	PROTECTION IGNITION WIRES 250N
20	30278	1		COPERCHIO ACCENSIONE 250/300 2T ES MY 19	IGNITION COVER 250/300 2S E.S. MY19->
21	F12322	1		O RING 2106	O-RING
22	49290	1		TAPPO COPERCHIO ACC. 250/300 2T MY 2019(PUO' SOSTITUIRE F49833)	CAP IGNITION COVER 250/300 2S MY19